



EXTRACTORES DE AIRE LÍNEA KDK MODELO AUHT

- Extractor de aire cuadrado para montaje en muros, ventanas y tabiques
- Templador gravitacional (metálico) antirretorno
- Uso en comedores, cocinas, dormitorios, livings, baños o bodegas.
- Marco y hélice fabricados en plástico ABS de alta resistencia
- Cuerpo totalmente metálico
- Motor de larga vida
- Libre de mantenimiento y rodamientos autolubricados
- Fabricado por Panasonic Life Solutions



Celosía antirretorno metálica



Bajo nivel de ruido



Plástico ABS alta resistencia



Certificación IP44



Larga durabilidad



Aspas con diseño avanzado



Bajo consumo eléctrico



ESPECIFICACIONES TÉCNICAS LÍNEA KDK-AUHT

MODELO	DIÁMETRO	CAUDAL	CONSUMO	TEMPLADOR O CELOSÍA	LUZ PILOTO	TIMER	PRESIÓN SONORA A 3M	STOCK
	mm	m3/h	Watts				dBa	
20 AUHT	200	580	21	✓	-	-	35	✓
25 AUHT	250	920	22	✓	-	-	36	✓
30 AUHT	300	1200	24	✓			35,5	✓



CARACTERÍSTICAS AERODINÁMICAS

20 AUHT

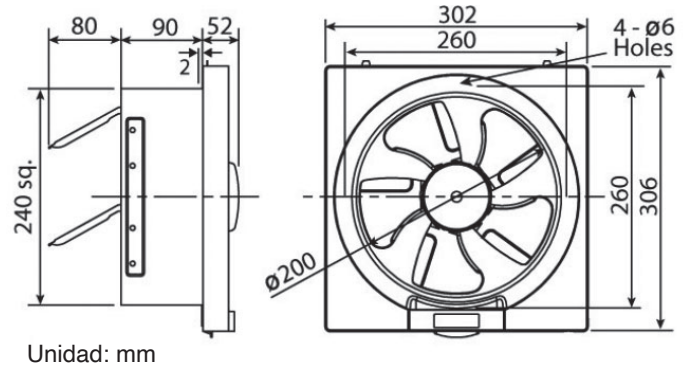
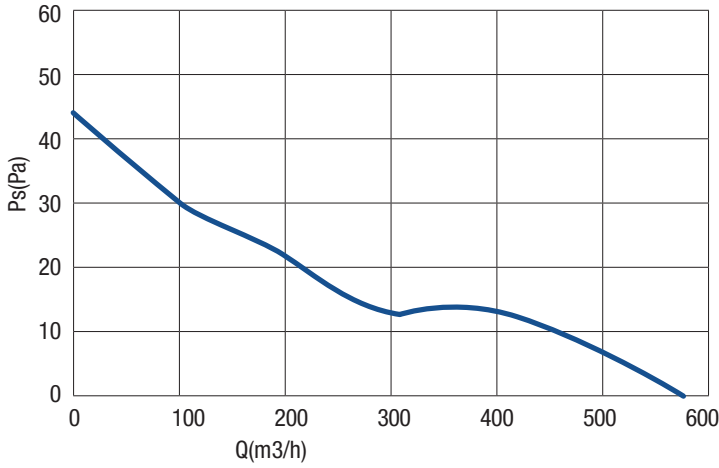

25 AUHT

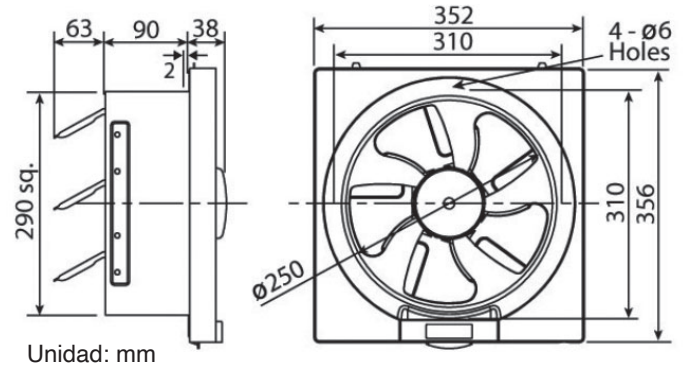
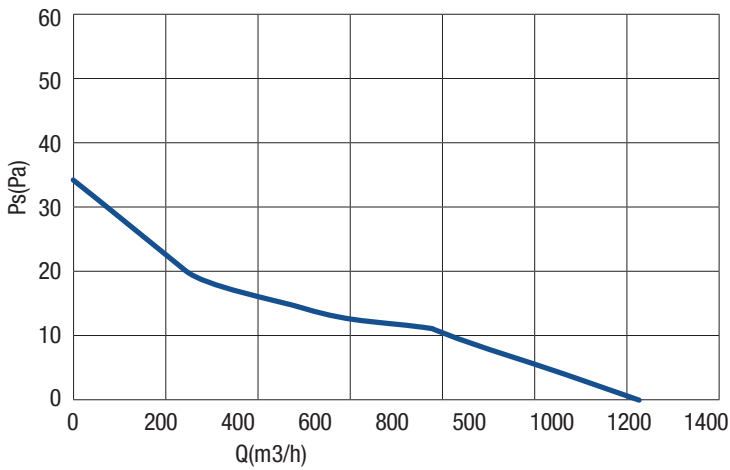

30 AUHT

