

HALGAN MGT 1000 GREASE TRAP DETAIL

Notes

1. **General**
 - 1.1. Tank constructed from Polyethylene.
 - 1.2. The MGT is to be installed in a location that will not cause a nuisance, obstruct fire access, cannot be vandalised or be damaged by vehicles.
 - 1.3. The MGT must have ease of access to pumpout point for maintenance.
 - 1.4. A hose tap fitted with RPZD backflow protection (as per AS/NZS 3500) must be installed within 5 metres of the grease trap for maintenance and cleaning.
 - 1.5. Non standard installations require Halgan approval.
2. **Installation above ground**
 - 2.1. The MGT is to be supported on a 100mm thick concrete pad.
 - 2.2. The MGT does not require a stand.
 - 2.3. Any maintenance platform must be installed in accordance with Australian Standard 1657-1992 allowing safe access while inspecting and maintaining the MGT
 - 2.4. All pipes connecting to the MGT shall be fully supported; there shall be no stress on the tank connections.
 - 2.5. All stormwater must be diverted away from the MGT to prevent undermining of foundation.
3. **Installation below ground**
 - 3.1. All connections to the MGT shall be in accordance with the appropriate authorities.
 - 3.2. Any excavation exceeding 1.5 metres in depth shall comply with the construction safety acts and regulations before backfilling.
 - 3.3. The MGT must be filled with water prior to backfilling.
 - 3.4. Riser heights greater than 900mm require Halgan approval
4. **Excavation dimensions**
 - 4.1. The excavated hole width shall be kept as narrow as practicable. The depth shall not be greater than 150mm more than the required depth.
 - 4.2. 75mm clearance is required at the sides of tank.
5. **Over excavation**
 - 5.1. Where an excavation has been made deeper than required, the excess depth shall be filled either with bedding material compacted to achieve 98% compaction or concrete.
6. **Water Charged Ground**
 - 6.1. Where installation is in high water table or water charged ground, mine subsidence, filled or unstable areas, the services of a qualified structural engineer is required for certification.
7. **Bedding material**
 - 7.1. The bedding material shall be 1 part Portland cement to 4 parts clean sand.
 - 7.2. The bedding shall be thoroughly compacted by tampering at 300 mm layers.
 - 7.3. The bedding material shall encase the whole tank.
8. **Final Backfill**
 - 8.1. The final backfill material shall comply with the following:
 - 8.1.a. Spoil from the excavation of the trench may be used.
 - 8.1.b. Foreign material such as builder's waste, bricks, and concrete shall not be used.
 - 8.1.c. The backfill shall be compacted to restore the excavated hole as near as practicable to the normal ground.

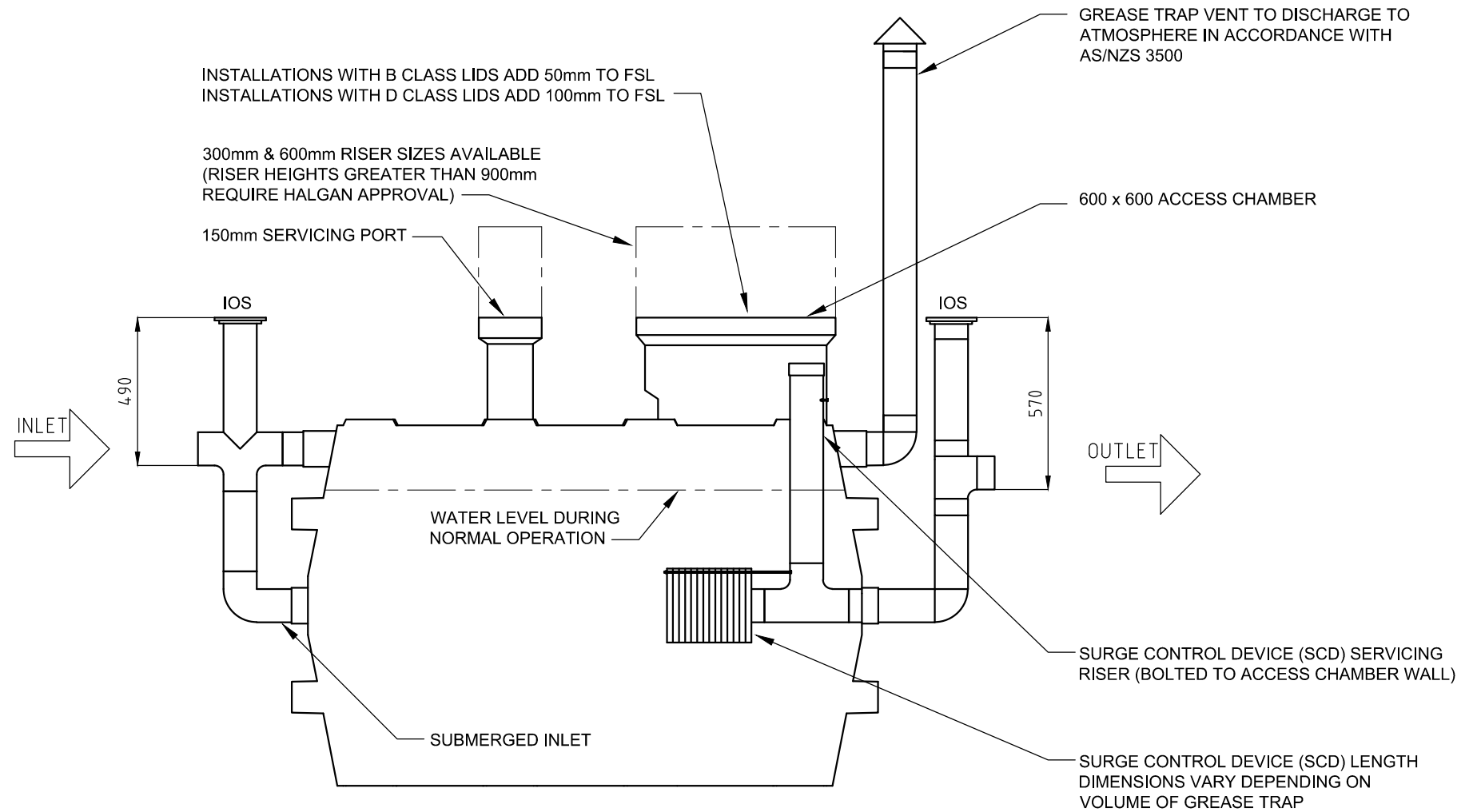

HALGAN MGT 1000 GREASE TRAP DIMENSIONS					
MODEL	HEIGHT	WIDTH	LENGTH	VOLUME	WEIGHT
MGT 1000	1550mm	720mm	2060mm	1000 L	100 KG

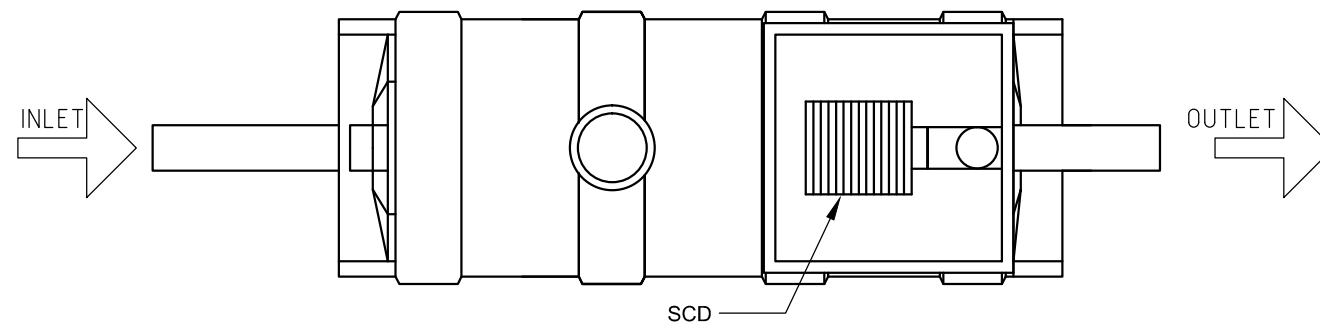

REV	DATE	DESCRIPTION	BY	CHKD	APP
A-1	22.05.2013	NOTES & TITLE BLOCK AMENDED	DN	SM	KH
A	05.10.2012	DETAIL DESIGN	DN	SM	KH

THIS DRAWING AND THE INFORMATION CONTAINED HEREON ARE THE PROPERTY OF HALGAN PTY LTD AND MUST NOT BE COPIED, REPRODUCED OR USED WITHOUT THE WRITTEN PERMISSION OF HALGAN PTY LTD.

DO NOT SCALE IF IN DOUBT ASK



halgan pty ltd
halgan.com.au

Freecall 1800 626 753
PO Box 255
Collaroy NSW 2097
admin@halgan.com.au
www.halgan.com.au



HALGAN 1000 LITRE
GREASE TRAP DETAIL

DRAWN	DATE
DN	05.10.2012
CHECKED	SCALE
SM	1:20
DWG. NO.	REV.
MGT1000	A-1