

INSTALLATION INSTRUCTIONS C-VS-2200-EXPL

22" Vehicle specific console 2020-22 Retail Ford Explorer

TOOLS REQUIRED:

| | | | |
|-------------------|---------------------|---------------------|----------------------|
| Metric socket set | Ratchet | Panel removal tool | T-20 Torx driver |
| Pick tool | Standard wrench set | Standard socket set | Phillips screwdriver |

PARTS and MOUNTING HARDWARE:

| <u>QTY</u> | <u>DESCRIPTION</u> | <u>PART#</u> |
|------------|---------------------------------------|--------------|
| 1 | Rear floor mounting bracket | 22924 |
| 1 | Front cross support bracket | 22929 |
| 1 | Driver side floor mounting bracket | 22766 |
| 1 | Passenger side floor mounting bracket | 22767 |
| 1 | Driver side trim panel | 22930 |
| 1 | Passenger side trim panel | 22931 |
| 2 | Speaker grill | 12662 |
| 2 | Half-moon cover plate | 22932 |
| 1 | Blank cover plate | 22933 |
| 1 | Shifter plate assembly | 22935 |
| 25 | #8 x 3/8" Torx screws | 13405 |
| 10 | 1/4" Serrated nut | 16013 |
| 11 | #10 Flat washer | 16120 |
| 6 | 1/4" Flat washer | 16122 |
| 6 | 1/4" Split lock washer | 16142 |
| 2 | 1/4" x 1" Fender washer | 16210 |
| 8 | 1/4" x 3/4" Carriage bolt | 16223 |
| 6 | 1/4" x 3/4" Hex head bolt | 16326 |
| 11 | 10-32 x 1/2" Phillips machine screw | 16399 |

Always!

- Read all instructions before installing any Havis, Inc. products.
- **Check for obstructions (Wires, brake lines, fuel tank, etc.) before drilling any holes!**
 - Use hardware provided with install kit

C-VS-2200-EXPL

**2WD models will require part number
CM011192 for selector switch.**

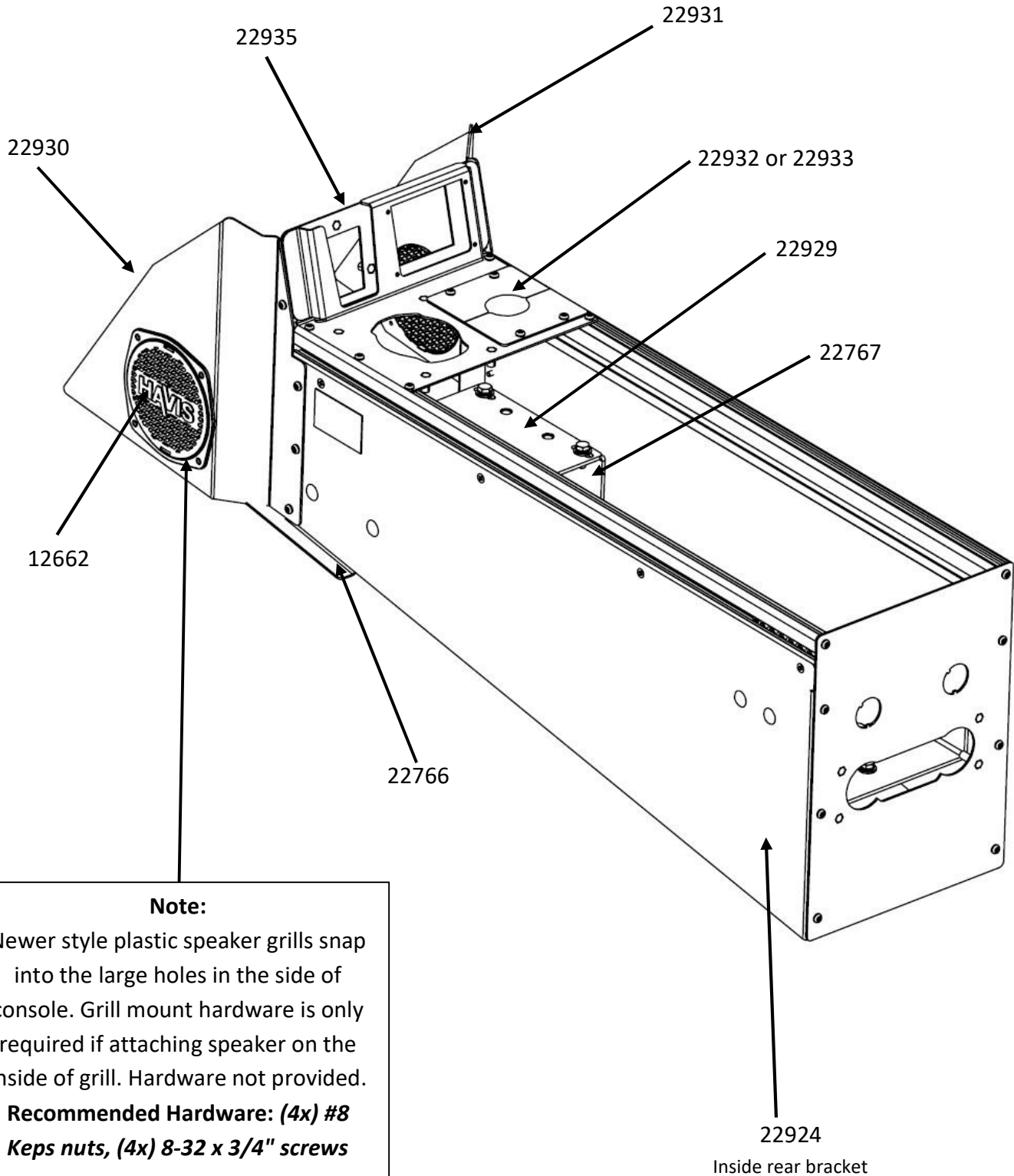

Note:

Newer style plastic speaker grills snap into the large holes in the side of console. Grill mount hardware is only required if attaching speaker on the inside of grill. Hardware not provided.

**Recommended Hardware: (4x) #8
Keps nuts, (4x) 8-32 x 3/4" screws**



View of 2020 Ford Explorer interior prior to install



Remove (1) bolt each side at rear of OEM console.
(10mm socket)



Unsnap OEM console lower trim on driver and passenger sides.
Remove (1) bolt each side from forward end of the console. *(7mm socket)*
Unplug USB on driver side



Remove (1) bolt each side from side of console. *(10mm socket)*
Disconnect (2) plugs at front passenger side of console.



Disconnect (2) plugs from both middle sides of OEM console.
(Driver side not shown)



Slide OEM console away from dash and remove from vehicle.



Remove OEM rear end panel and disconnect all plugs.



Remove rear 12v sockets and rear HVAC control from OEM console end panel.



Relocate OEM 12v sockets and rear HVAC control to new end panel. Attach control with supplied 10-32 x 1/2" screws and flat washers.



Remove OEM aux panel and 12v socket from forward section of OEM console.



Gently pry up top of console using a panel removal tool.



View of top lifted up.



Disconnect all wire plugs

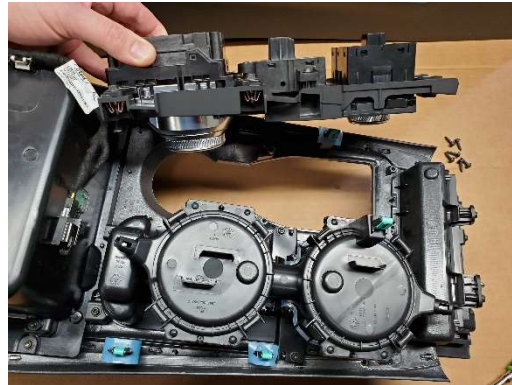

Remove section with housing shifter, terrain control, and emergency brake switch.
(T-20 Torx bit)



Carefully unsnap the Drive mode switch from the bezel.



Unscrew the shifter and emergency brake switch from the bezel.

2WD models will require part number CM011192 for mode switch.



Install previously removed parts into new shifter plate using supplied 10-32 x 1/2" Phillips machine screws.



Remove side panels from OEM console and remove harness. Harness will need to be re-installed into vehicle.

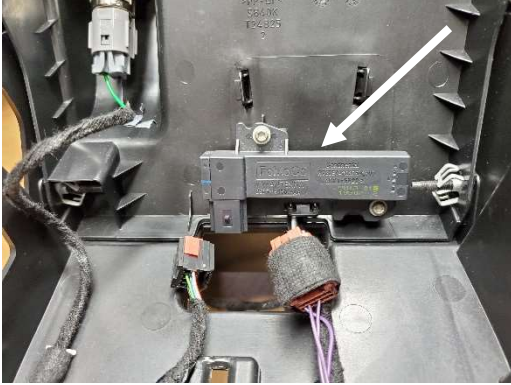

If vehicle is equipped with a proximity key, the sensor will need to be unscrewed and relocated. This is located inside of the OEM console.



Relocate sensor to rear floor mounting bracket using supplied 1/4" x 3/4" bolts, washers, and serrated nuts.



Remove OEM nuts from studs on front section of floor. *Note: Nuts may be under vent tube mount flange from factory.*



Install driver and passenger side forward floor mounting brackets under OEM vent tube and bracket. **Mounting brackets must be resting on metal floor.**



Bolt brackets to studs with supplied 1/4" x 1" fender washer and OEM nut. Washers prevent nuts from slipping through hole in vent tube mount flange.

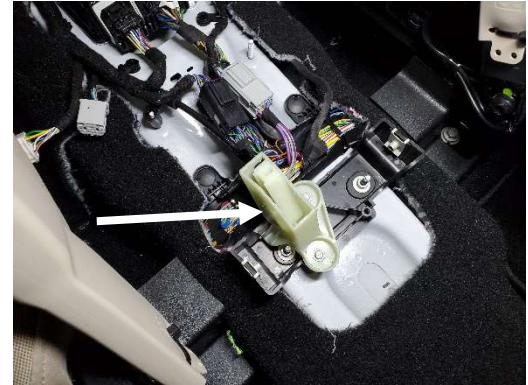

Note: Plastic parking brake override lever shown. This can be accessed after new console installation by removing top panels or accessories. *See OEM owner's manual.*



Attach rear floor mount bracket with previously removed rear 10mm head bolts. Make sure bracket is level and tighten bolts.



Slide console housing into vehicle and line up to forward mounting brackets.



Attach console to front and rear mounting brackets using 1/4" x 3/4" carriage bolts and serrated nuts.



Attach cross support to forward mounting brackets using (4) 1/4" x 3/4" hex head bolts, split lock washers, and flat washers.



Plug OEM harness back in and route throughout console. Plug into shifter, emergency brake, and drive mode switches. Attach panel assembly to console with (5) #8 x 3/8" Torx head screws.



Attach speaker grills to side filler panels and attach fillers to console with #8 x 3/8" Torx head screws.



In addition to speaker grill, install previously removed OEM USB aux panel and 12v socket into passenger side filler panel.



Half-moon cover plate shown with optional C-HDM-208 pole bolted to cross over bracket. Blank cover plate is used if pole is not installed.



Wire and mount equipment. Photo shows blank cover plate.



Installation is now complete



Optional C-HDM-208 shown with C-MD-119, and DS-PAN-1111

