

INSTALL INSTRUCTIONS C-VS-1100-F150-3

2021 Ford F-150 XL and XLT Pickup

Vehicle Specific Console with 11" inches of Equipment mounting space

For trucks with 40/20/40 split bench seats or 40/mini console/40 seats

**** Does not work with 4 X4 floor shifter or higher trim level trucks with full length center console****

TOOLS REQUIRED:

Ratcheting wrench
T-20 Torx Driver Bit

Panel removal tool
7/16" Wrench

Metric/Standard Socket Set

PARTS and MOUNTING HARDWARE:

<u>QTY</u>	<u>DESCRIPTION</u>	<u>PART#</u>
1	Base mounting bracket	24931
1	USB and 12v socket relocation plate	25517
1	Extrusion nuts	25520
4	#8 Torx screws for EB	13405
8	1/4" Serrated nut	16013
6	1/4" x 1/2" Carriage bolt	16222
2	1/4" x 3/4" Carriage bolt	16223

**C-VS-1100-F150-3
Assembly drawing**

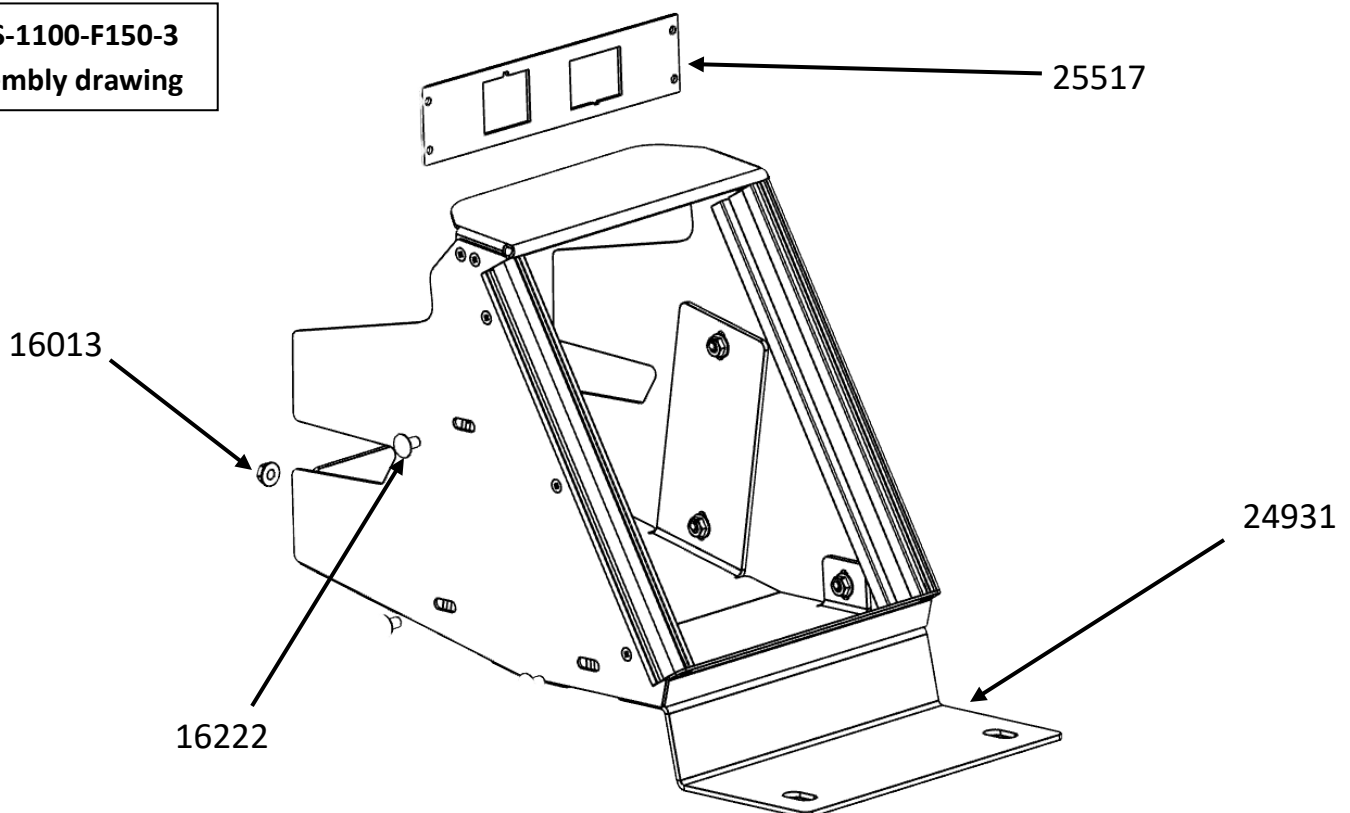



View of F-150 interior prior to install



Remove OEM 12v socket and USB plate



Unplug and remove from dash



View of USB relocation plate



Snap USB and 12v socket into plate



Remove bolts from front, sides of middle seat



Remove bolts from rear, sides of middle seat.



Unbolt forward, floor-mounting bracket

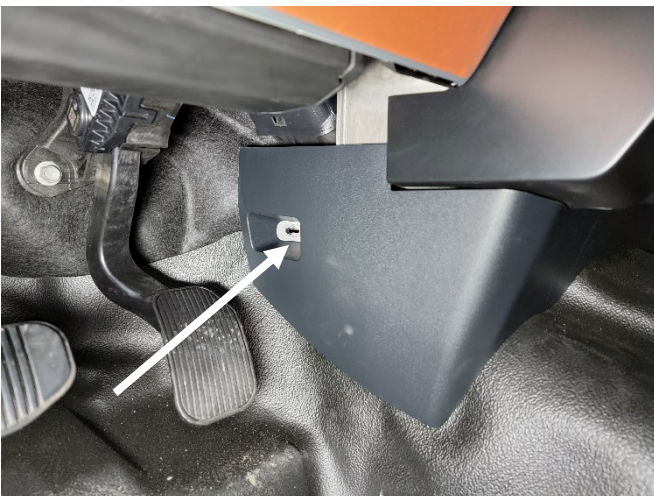

Locate 7mm head bolt from lower center of dash.



Remove lower trim



Place base mounting bracket in vehicle and line up to holes in floor.



Install (2) 1/4" x 1/2" carriage bolts through the front of the bracket through the lower dash slots.



Install 1/4" serrated nuts onto the previously installed carriage bolts and tighten.



Place the lower dash trim into place, mark around mounting base and trim as needed to reinstall.



Reinstall previously removed OEM floor mounting bracket and torque to manufacturer's specifications.



Slide console in over main mounting bracket and install using (6) 1/4" x 3/4" carriage bolts and serrated nuts.



Wire, mount and install equipment prior to reinstalling OEM center seat.



Installation is now complete.