



# PHOENIX

## SPECIFICATIONS

**TOI**

### SINK MIXER 180MM SQUARELINE

PRODUCT CODE: 108-7320-60  
 FINISH: CHROME / MATTE BLACK  
 WELS: 5 STAR - 6.0 LT/MIN

#### INFORMATION:

TEMPERATURE RATING: MIN 1° - MAX 75°  
 PRESSURE RATING: MIN 150 kPa - MAX 500 kPa



ALSO AVAILABLE IN:



CHROME  
 MATTE BLACK /  
 BRUSHED  
 ROSE  
 GOLD

FOR MORE INFORMATION VISIT  
[www.phoenixtapware.com.au](http://www.phoenixtapware.com.au)

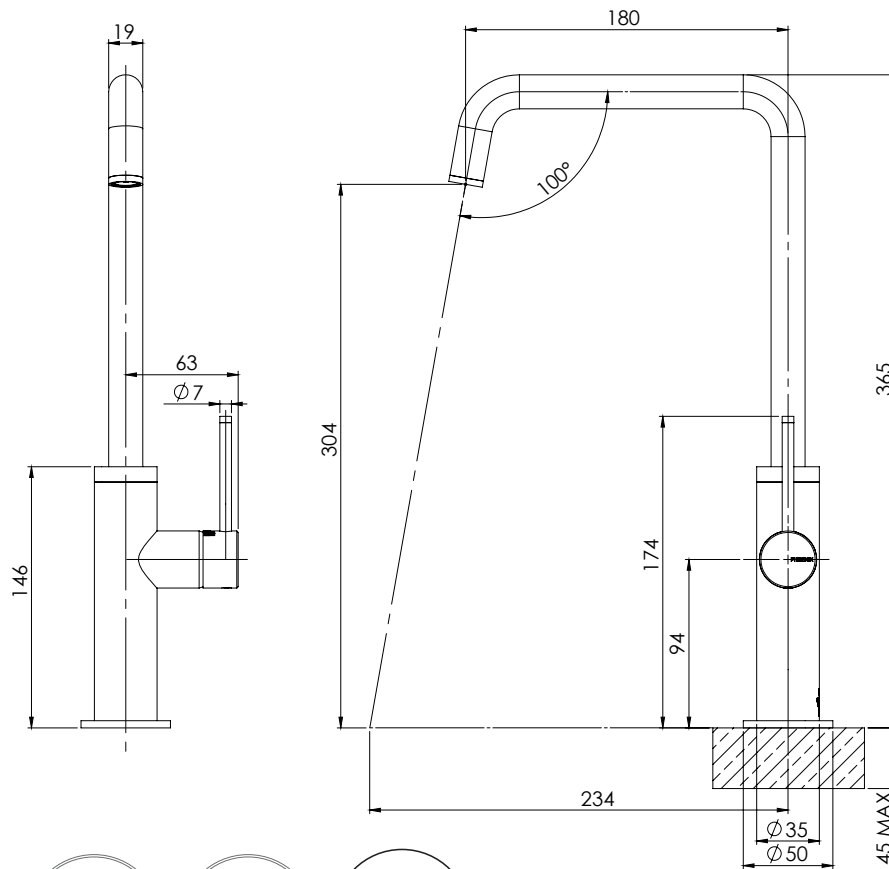

PLEASE [CLICK HERE TO VIEW FULL WARRANTY](#)

While we aim to ensure the specifications shown are correct at time of printing, Phoenix Tapware reserves the right to make modifications without prior notice. Always use the physical product measurements for mark-ups and roughing-in as the line drawing shown may differ from the actual product over time. All measurements are shown in millimetres.

A Registered Design and Trademark of Phoenix Industries Pty. Ltd.

V100717

[www.phoenixtapware.com.au](http://www.phoenixtapware.com.au)  
 03 9780 4200



### TOI

## SINK MIXER 180MM SQUARELINE

PRODUCT CODE: 108-7320-60  
 FINISH: CHROME / MATTE BLACK  
 WELS: 5 STAR - 6.0 LT/MIN



### PARTS LIST

1. MIXER BODY
2. CARTRIDGE SEAT
3. THREADED TAIL
4. CARTRIDGE SEAT SHAFT
5. 25MM CARTRIDGE
6. HANDLE
7. MIXER DOME
8. DRESS PLATE
9. SWIVEL OUTLET
10. AERATOR RETAINER
11. O-RING
12. AERATOR
13. O-RING
14. O-RING 26X2.5MM
15. GRUB SCREW M5X5
16. GRUB SCREW CAP
17. LEVER PIN
18. LEVER TOP CAP
19. COPPER EXTENSION
20. FLEXIBLE HOSE 450MM HOT
21. FLEXIBLE HOSE 450MM COLD
22. SWIVEL SPACER
23. LOCKNUT PLASTIC
24. LOCKNUT GASKET
25. LOCKNUT SPACER
26. WASHER

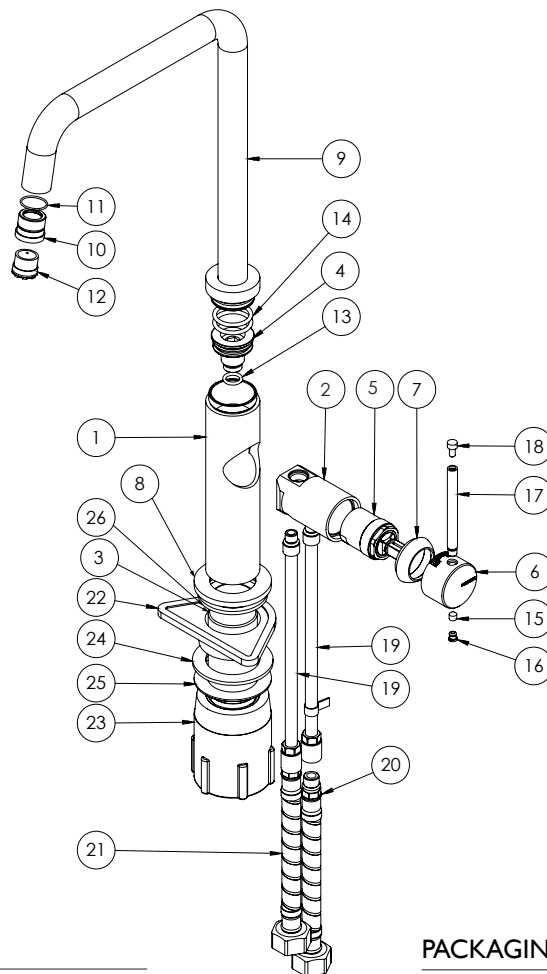

### MAINTENANCE AND CARE:

- All surfaces should be cleaned with mild liquid detergent or soap and water.
- Do not use cream cleaners or citrus based cleaning products, as they are abrasive.
- Use of unsuitable cleaning agents may damage the surface. Any damage caused in this way will not be covered by warranty.

### PACKAGING INCLUDES

- 1 x Sink mixer
- 1 x Rubber gasket, plastic locknut & locknut spacer
- 1 x Swivel spacer
- 1 x 450mm braided flexible cold hose
- 1 x 450mm braided flexible hot hose
- 1 x Installation kit
- 1 x Installation instructions
- 1 x Warranty card

PLEASE [CLICK HERE](#) TO VIEW FULL WARRANTY

While we aim to ensure the specifications shown are correct at time of printing, Phoenix Tapware reserves the right to make modifications without prior notice. Always use the physical product measurements for mark-ups and roughing-in as the line drawing shown may differ from the actual product over time. All measurements are shown in millimetres.

A Registered Design and Trademark of Phoenix Industries Pty. Ltd.  
 V100717

[www.phoenixtapware.com.au](http://www.phoenixtapware.com.au)  
 03 9780 4200