

# KYTIN - WALL MIXER WITH UPSWEPT WALL BASIN OUTLET AND PLATE (RH/LH)<sup>+</sup>

## WATER EFFICIENT TAPWARE

(NOMINAL FLOW RATE = 5 L/min)

### PLUMBERS INSTALLATION INSTRUCTIONS

#### Important Information

- \* To ensure the wall elbow (14<sup>+</sup>) is mounted accurately, a plastic template (16) is supplied to assist with installation.
  - \* Not suitable for gravity feed systems.
  - \* Brazed connections should NOT be made directly onto the mixer, as excessive heat will cause permanent damage.
  - \* Basin outlet is fitted with a 5 L/min flow regulated aerator insert. This low flow rate may not be suitable for connection to some Instantaneous Gas Water Heaters, some Tempering Valves, some Solar Water Heaters & some Thermostatic Mixing Valves. Check with the manufacturers of these products. Note:- An 8 L/min aerator insert kit (Part No. 20742), is available if required.
  - \* All pipework must be thoroughly flushed prior to installation, as foreign materials may block the flow regulating device and reduce the flow of water.
- Note: Aerator insert housing must be retightened to prevent removal by hand.

#### Installation

- 1) Fit mixer body (12) onto a suitable mounting plate or noggin in the wall and secure using screws through the holes in its base. When facing the mixer, the connections should be as follows : Hot water inlet connection 'H' to the left. Cold water inlet connection 'C' to the right. Mixed water outlet connection, vertically upwards.
- Note : A suitable elbow fitting (15<sup>+</sup>) should be fitted to the inlet connection adjacent to the basin outlet (13) (Fig.3). Check all connections for leaks.
- Important :**
  - \* Mixer body (12) must be installed square to wall/tile face, to ensure cover plate (8) sits flush.
  - \* To avoid damaging the decorative finish, do not remove the protective sleeve until installation has been completed.
- 2) Determine the orientation of the basin outlet (to the right or left of mixer body)(Fig.2). Connect the outlet of mixer body to the inlet of wall elbow (14<sup>+</sup>) using suitable pipework. **Note:** Pipework and fittings are not supplied. Fit the large hole of the template (16) over the protective sleeve of the mixer body with the G1/2B outlet thread of the wall elbow (14<sup>+</sup>) located in the remaining hole as shown in Fig. 4. **Note:-** The flat face of the template must be at the back. Place a spirit level on the corner pegs at the top of the template, then when the alignment is horizontal fix the wall elbow using suitable screws through the holes in its base. Remove template (16) & discard.
- 3) Fit cover plate (8) followed by retaining ring (7) onto mixer body (12). Rotate the retaining ring until pin is engaged in slot in cover plate and position so that the screws (6) are at the bottom. Push retaining ring and cover plate firmly against wall/tile face and tighten screws (6) using 2mm allen key (5).

- 4) Fit handle (1) taking care that it is pushed fully down, tighten screw (2) using the 2.5mm allen key (3). Screw handle lever (4) into handle (1) & tighten firmly by hand, taking care not to damage the decorative finish.

Check that the G1/2B outlet thread of the wall elbow (14<sup>+</sup>) protrudes 10- 12mm from the face of the cover plate (8). Cut to length if required. Apply thread tape to the thread of wall elbow (14<sup>+</sup>). **Important:** Care must be taken that thread tape cannot become dislodged and block the flow regulating device, causing a reduction in water flow. Screw the basin outlet onto the thread and position as required. DO NOT OVERTIGHTEN.

- 6) Turn on Hot and Cold water supplies and check operation.

#### Replacing Cartridge

- 1) Turn off hot and cold water supplies.
- 2) Carefully unscrew handle lever (4). Using 2.5mm allen key (3) loosen screw (2) and remove handle (1). Unscrew cap (9) taking care not to damage the decorative finish. Unscrew retaining nut (10) and remove the old cartridge (11).
- 3) Ensure inside of mixer body (12) is clean. First check that seal is in position in base of new cartridge then fit new cartridge (11) into mixer body taking care that two lugs on base of cartridge fit into mating holes in mixer body. Screw on nut (10). **Important :** Nut (10) should be tightened to a torque of 10Nm. Replace cap (9) tightening by hand.
- 4) Fit handle (1) taking care that it is pushed fully down, tighten screw (2) using the 2.5mm allen key (3). Screw handle lever (4) into handle (1) and tighten firmly by hand, taking care not to damage the decorative finish.

| IMPORTANT                            |  |
|--------------------------------------|--|
| Pressure & Temperature Requirements. |  |
| •                                    | Hot and cold water inlet pressures should be equal.  |
| •                                    | Static inlet pressure range : 150 - 1000 kPa<br>New Regulation :- 500 kPa maximum static pressure at any outlet within a building.<br>(Ref. AS/NZS 3500.1- 2003, Clause 3.3.4) |
| •                                    | Maximum hot water temperature : 80°C.  |

+ Not supplied.

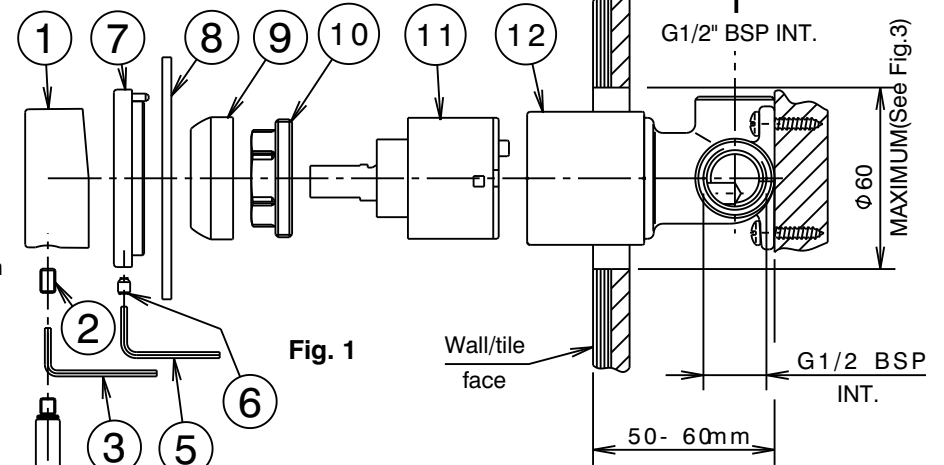

Fig. 1

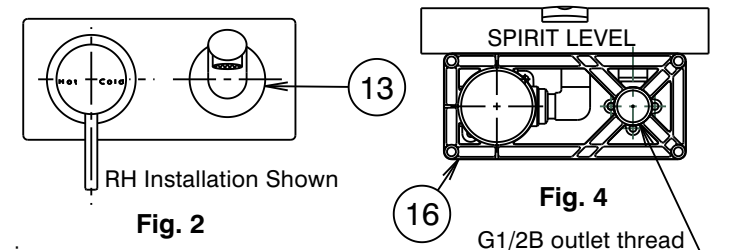

Fig. 2

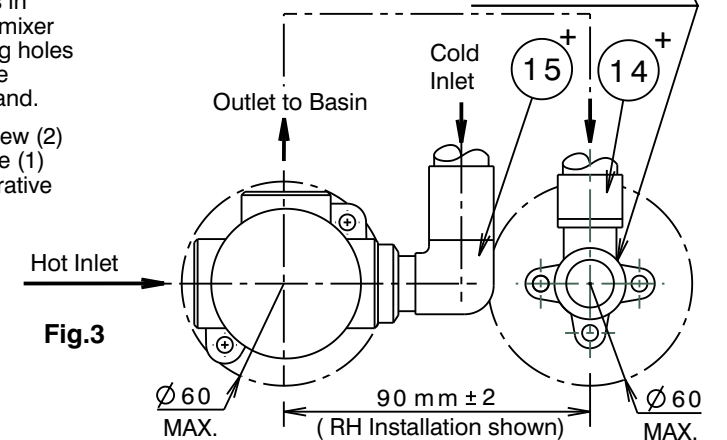

Fig. 3

Distributed by:  
Dorf Clark Industries Limited  
ABN 23 004 394 923

IS684C(10/11)