

UF13D

Ultraform

Oliveri®

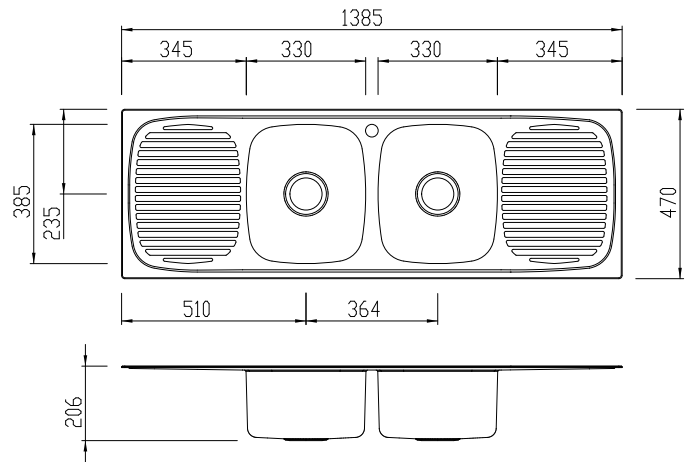

INCLUDED ACCESSORIES

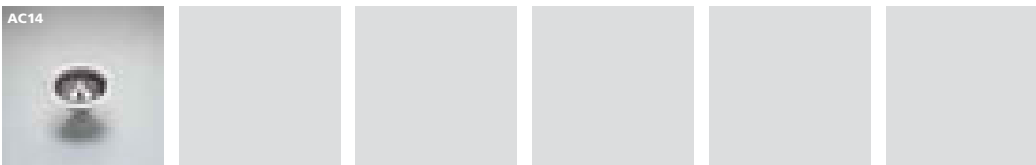

RECOMMENDED TAPWARE



OPTIONAL ACCESSORIES

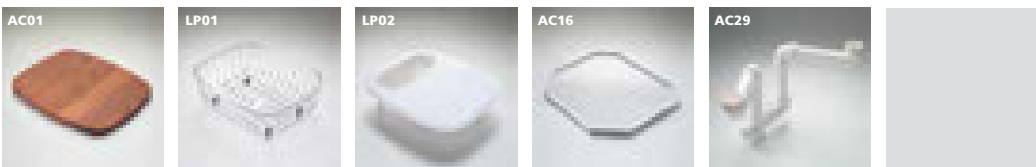

SPECIFICATIONS

Description

Double bowl inset sink with double drainer

Sink Size

1385W x 470H

Deep Bowl

330W x 385H x 190D / 21L

Deep Bowl

330W x 385H x 190D / 21L

Construction

2 piece, bowls & drainer seam welded

Material

304 grade, 18/10 polished stainless steel (0.8mm thick)

Installation

Inset recommended.

Fixings

Adjustable clips and sealing foam supplied

Cut Out Template

1365 x 450 x 15mm radius

Min Cabinet Size

800mm

Tap holes

Available 0 or 1 tap hole (specify when ordering)

Waste fittings

2 x 90mm basket wastes included

Overflow

Not available

Carton Size

1395 x 480 x 210mm

Weight

8.5kg

Warranty

Lifetime manufacturer's warranty (refer to oliverisinks.com)

For more information call **1300 13 7465** or visit **www.oliverisinks.com**

