

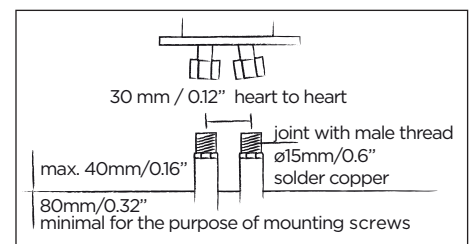

JEE-O original bath mixer specifications

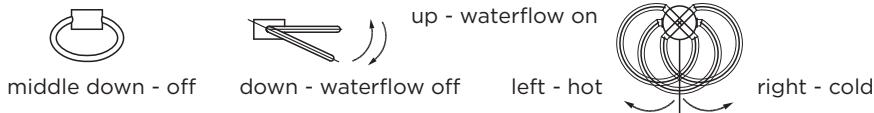
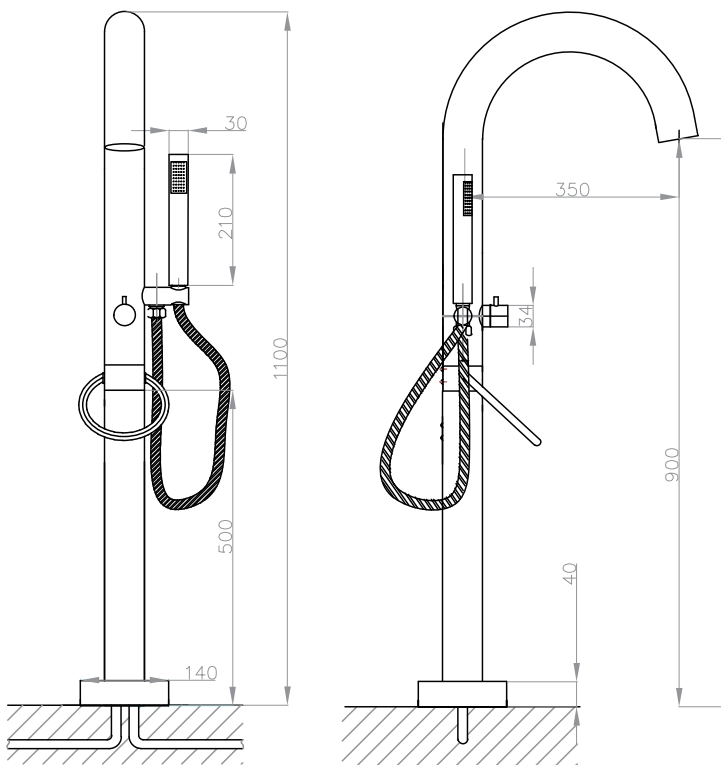

Article code:

- 100-3110**
● brushed stainless steel
- 100-3111**
● polished stainless steel

Material:

Stainless Steel r304

Cartridges:

Sedal ceramic mixing mechanism (35mm), item code **005-0101** and JEE-O ceramic diverter mechanism, item code **005-0302**

Cleaning:

JEE-O protect

Flow at water of 38°C / 100,4°F:

10l p/m at 3bar pressure

Flexhose:

150 cm length

Connection:

2 x G 1/2" (ø15mm / 0.6") nylon^(out)/epdm⁽ⁱⁿ⁾ flexhose with brass swivel British Standard Pipe (BSP)

Thread:

Dimension package: L 68 x W 53 x H 21 cm

Total weight: 10.0 kg

Package weight: 1.5 kg

Placing on a water-tight floor

2 year warranty

HS code:

84818011900

Approvals:

CE-EN 200-2008

