

avenir®

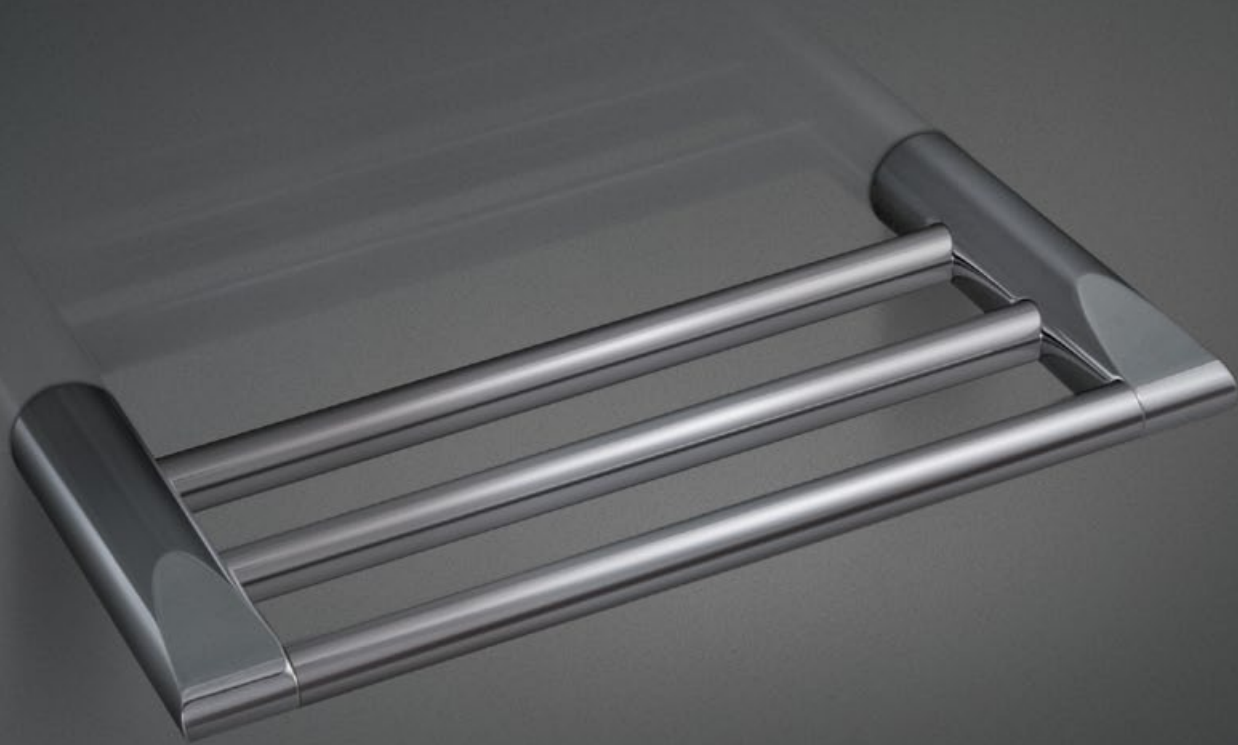

BATHROOM ACCESSORIES

TAGO

Important Information

All dimensions stated in this brochure are approximate. Dimensions and designs are subject to change without prior notice. Visit the website at www.avenir.com.au for the latest information and up-to-date specifications.

Features Guide

The table below shows the various features available in each Avenir range. For further information on the complete Avenir collection, ask your local retailer, or visit the website at www.avenir.com.au.



	ARTIZEN	TAGO	BAGNO	BIZU	BLOQUE	PLUS	MINUS	UNIVERSAL
Australian Made	•	•	•	•	• ¹	•	•	• ¹
MATERIAL/FINISH								
Chrome-Plated Brass ²	•	•	•	•	•	•	•	•
CUSTOM FINISHES³								
Satin	•	•	•	•	•	•	•	•
Nickel	•	•	•	•	•	•	•	•
Brushed	•	•	•	•	•	•	•	•
FIXING SYSTEMS								
Double-Fixing	•	•	•	•	•	•	•	•
Optional Glass Fixing	•	•	•	•	•	•	•	•
Optional Back-Plate	•	•	•	•	•	•	•	•
WARRANTY								
10 year Fit & Finish ⁴	•	•	•	•	•	•	•	•

¹ Range features selected imports

² Soap Racks use Stainless Steel 316 Rods. Heated Towel Ladders & Rails use mirror-polished Stainless Steel 304.

³ Surcharges apply. Ask your local retailer for further information.

⁴ Excluding glass and selected imported products. The warranty covers any manufacturing material and workmanship defects. Terms and conditions apply. The warranty for Soap/Lotion Dispensers is only valid for residential use. Heated Towel Ladders & Rails are supplied with a 3 year warranty, subject to the terms & conditions of sale.

TAGO



Toilet Roll Holder (Right Facing)



Double Toilet Roll Holder



Hand Towel Rail (Right Facing)



Single Towel Rail



Double Towel Rail

Toilet Roll Holder

TASTRH-LF	Left Facing	h 38	w 136	d 80 mm
TASTRH-RF	Right Facing	h 38	w 136	d 80 mm

Double Toilet Roll Holder

TADTRH	h 38	w 247	d 80 mm
--------	------	-------	---------

Hand Towel Rail

TAHTR-LF	Left Facing	h 100	w 220	d 80 mm
TAHTR-RF	Right Facing	h 100	w 220	d 80 mm

Single Towel Rail*

TASTR 230	h 25	w 230	d 80 mm
TASTR 350	h 25	w 350	d 80 mm
TASTR 650	h 25	w 650	d 80 mm
TASTR 900	h 25	w 900	d 80 mm

Double Towel Rail*

TADTR 650	h 25	w 650	d 110 mm
TADTR 900	h 25	w 900	d 110 mm

* Custom lengths available on request

TAGO



Extended Towel Rail

Heated Towel Ladder (Non-Heated option available)

Wattage	45 / 50 / 65 / 90 / 90 Watts
Voltage	240 V AC / 50Hz
Material	304 Stainless Steel
Finish	Mirror polished
IP Rating	IPX5
Cable Options	Plug-In or Concealed
Heating Method	Dry Internal Heating Element
Heating Time	5 to 10 minutes



Extended Towel Rail

TASTR 1275	h 25 w 1275 d 80 mm
TASTR 1775	h 25 w 1775 d 80 mm

Custom lengths available on request

Heated Towel Ladder

TLH1-60x40	h 600 w 428 d 100 mm
TLH1-60x48	h 600 w 508 d 100 mm
TLH1-60x60	h 600 w 628 d 100 mm
TLH1-60x75	h 600 w 778 d 100 mm
TLH1-60x90	h 600 w 928 d 100 mm



Soap Rack

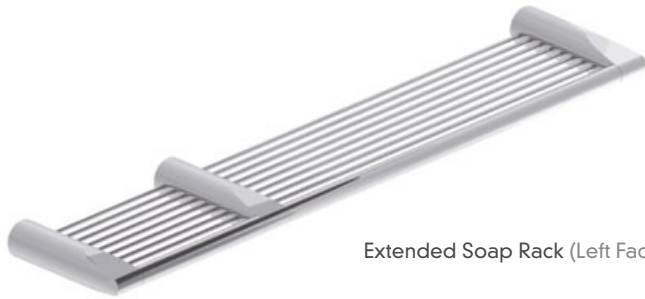

Extended Soap Rack (Left Facing)

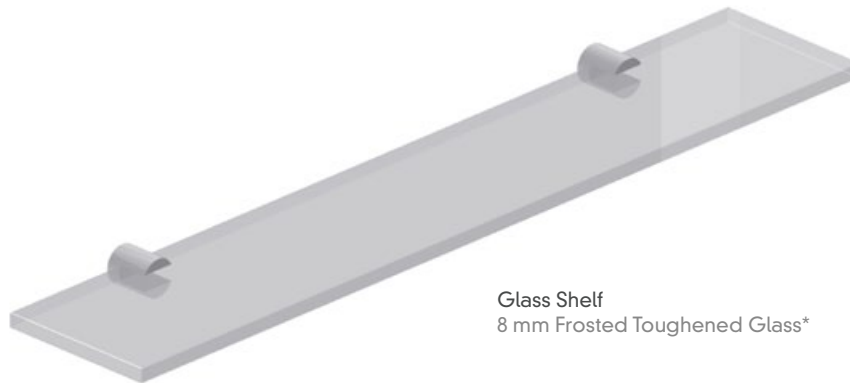

Glass Shelf
8 mm Frosted Toughened Glass*

Soap Rack

TASR 160
h 25 w 160 d 110 mm

TASR 230
h 25 w 230 d 110 mm

TASR 350
h 25 w 350 d 110 mm

Extended Soap Rack

TASR 485-LF
Left Facing 160+350
h 25 w 485 d 110 mm

TASR 485-RF
Right Facing 350+160
h 25 w 485 d 110 mm

Glass Shelf

TAGS 400
h 25 w 400 d 110 mm

TAGS 600
h 25 w 600 d 110 mm

* Also available in:

Clear Starfire Glass
300/450/600 x 10 mm

White-Painted Glass
300/450/600 x 10 mm

Foot Rest

TAFR 230

h 25 w 230 d 110 mm



Foot Rest

Robe Hook

TARH

h 40 w 25 d 45 mm



Robe Hook

Tumbler Holder

TATH-LF Left Facing

h 105 w 112 d 100 mm

TATH-RF Right Facing

h 105 w 112 d 100 mm



Tumbler Holder (Right Facing)
Removable Frosted Glass Tumbler included

Soap Dish

TASD-LF Left Facing

h 60 w 138 d 122 mm

TASD-RF Right Facing

h 60 w 138 d 122 mm



Soap Dish (Right Facing)
Removable Frosted Glass Dish included (no hole)

Toilet Brush

TATBS-LF Left Facing

h 404 w 128 d 115 mm

TATBS-RF Right Facing

h 404 w 128 d 115 mm



Toilet Brush (Right Facing)
Removable Cover & Frosted Glass Bowl included

Double-Fixing Installation

Avenir TAGO Bathroom Accessories feature a unique Fixing Installation System. Included in the installation kits are MDF templates for accurate positioning & drilling, aluminium mounting components for durability and strength, wall plugs, stainless steel screws and double-sided tape.

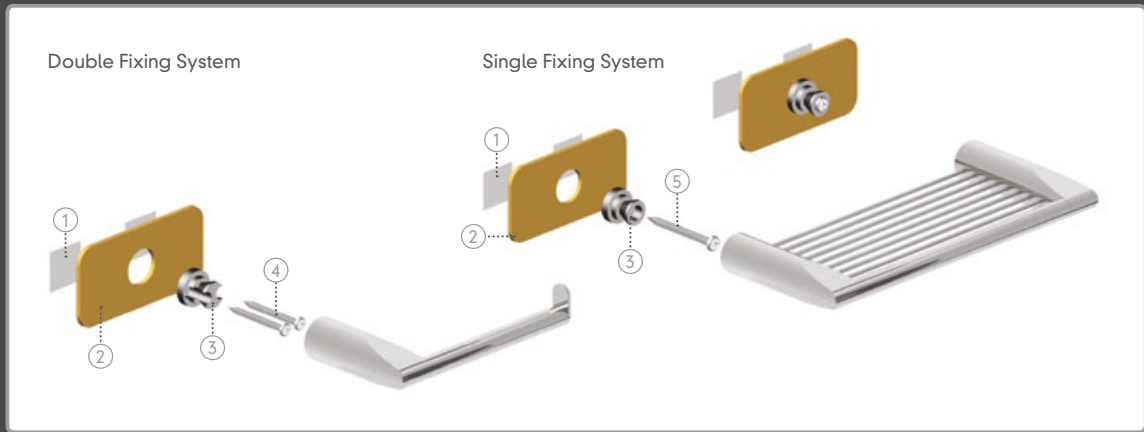

- ① Double-Sided Tape ② MDF Fixing Template ③ Aluminium Mounting Component
④ 8 Gauge Stainless Steel Screws ⑤ 10 Gauge Stainless Steel Screw

Glass-Fixing Kit

An optional component which allows you to fix TAGO Accessories to glass. (e.g. Shower screens)

TAGFK dia 36 depth 6mm + glass*

* 8 – 12 mm glass thickness, requires 10 – 12 mm hole.

Fixing plate

Nylon washers

Mounting component

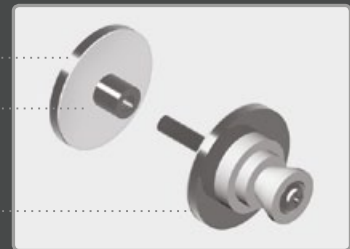

Back-Plate

A decorative design element which also serves as a useful mechanism for covering existing holes.

TABP dia 36 depth 3 mm

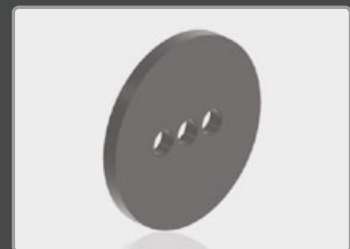

THE AVENIR COLLECTION

 ARTIZEN



 TAGO



 BAGNO

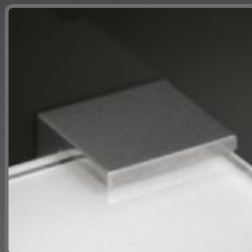

 BIZU



 BLOQUE

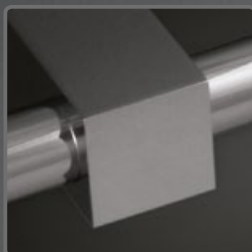

 PLUS



 MINUS

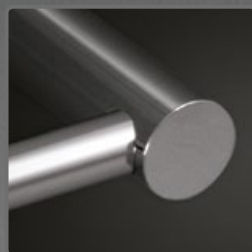

 UNIVERSAL



avenir®

Avenir Future Design Pty Ltd.

Unit 2/42 Leighton Place, Hornsby, NSW, 2077, Australia
PO Box 773, Hornsby, NSW, 1630, Australia

T +61 2 9476 6917

F +61 2 9476 5833

E sales@avenir.com.au

W www.avenir.com.au

