

TOI

VESSEL MIXER

PRODUCT CODE: 108-7900-00
 FINISH: CHROME
 WELS: 5 STAR - 6.0 LT/MIN

INFORMATION:

TEMPERATURE RATING: MIN 1° - MAX 75°
 PRESSURE RATING: MIN 150 kPa - MAX 500 kPa



ALSO AVAILABLE IN:



FOR MORE INFORMATION VISIT
www.phoenixtapware.com.au

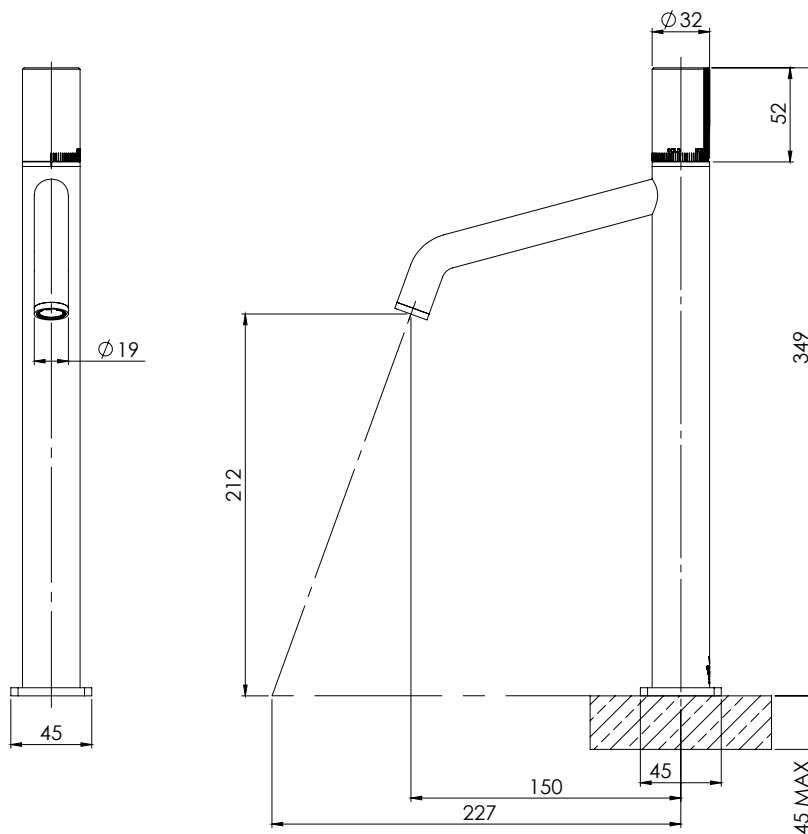

PLEASE [CLICK HERE](#) TO VIEW FULL WARRANTY

While we aim to ensure the specifications shown are correct at time of printing, Phoenix Tapware reserves the right to make modifications without prior notice. Always use the physical product measurements for mark-ups and roughing-in as the line drawing shown may differ from the actual product over time. All measurements are shown in millimetres.

Toi is a Registered Trademark of Phoenix Industries Pty Ltd
 V100717

www.phoenixtapware.com.au
 03 9780 4200



PHOENIX

SPECIFICATIONS

TOI

VESSEL MIXER

PRODUCT CODE: 108-7900-00
 FINISH: CHROME
 WELS: 5 STAR - 6.0 LT/MIN



PARTS LIST

1. MIXER BODY
2. 25MM PROGRESSIVE CARTRIDGE
3. LOCKNUT
4. MIXER RING
5. DRESS RING NUT
6. HANDLE WASHER
7. HANDLE
8. AERATOR RETAINER
9. AERATOR
10. HOSE EXTENSION HOT
11. HOSE EXTENSION COLD
12. DRESS PLATE
13. FLEXIBLE HOSE 450MM HOT
14. FLEXIBLE HOSE 450MM COLD
15. RUBBER WASHER
16. GRUB SCREW M5X5
17. THREADED TAIL
18. LOCKNUT GASKET
19. LOCKNUT PLASTIC
20. LOCKNUT SPACER
21. CARTRIDGE EXTENSION
22. SCREW
23. GRUB SCREW CAP
24. O-RING 14X1.0MM

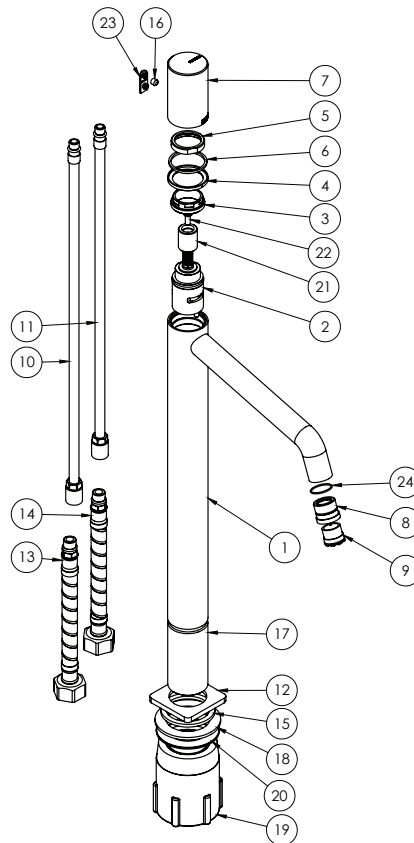

MAINTENANCE AND CARE:

- All surfaces should be cleaned with mild liquid detergent or soap and water.
- Do not use cream cleaners or citrus based cleaning products, as they are abrasive.
- Use of unsuitable cleaning agents may damage the surface. Any damage caused in this way will not be covered by warranty.

PACKAGING INCLUDES

- 1 x Vessel mixer
- 1 x Rubber gasket, locknut spacer & plastic locknut
- 1 x 450mm braided flexible cold hose
- 1 x 450mm braided flexible hot hose
- 1 x Installation kit
- 1 x Installation instructions
- 1 x Warranty card

PLEASE [CLICK HERE](#) TO VIEW FULL WARRANTY

While we aim to ensure the specifications shown are correct at time of printing, Phoenix Tapware reserves the right to make modifications without prior notice. Always use the physical product measurements for mark-ups and roughing-in as the line drawing shown may differ from the actual product over time. All measurements are shown in millimetres.

Toi is a Registered Trademark of Phoenix Industries Pty. Ltd
 V100717

www.phoenixtapware.com.au
 03 9780 4200