



PHOENIX

SPECIFICATIONS

VIVID SLIMLINE OVAL

BASIN MIXER

PRODUCT CODE: VV770-40
 FINISH: BRUSHED NICKEL
 WELS: 6 STAR - 4.5 LT/MIN

INFORMATION:

TEMPERATURE RATING: MIN 1° - MAX 75°
 PRESSURE RATING: MIN 150 kPa - MAX 500 kPa



AVAILABLE IN:



CHROME BRUSHED NICKEL MATTE BLACK

FOR MORE INFORMATION VISIT
www.phoenixtapware.com.au

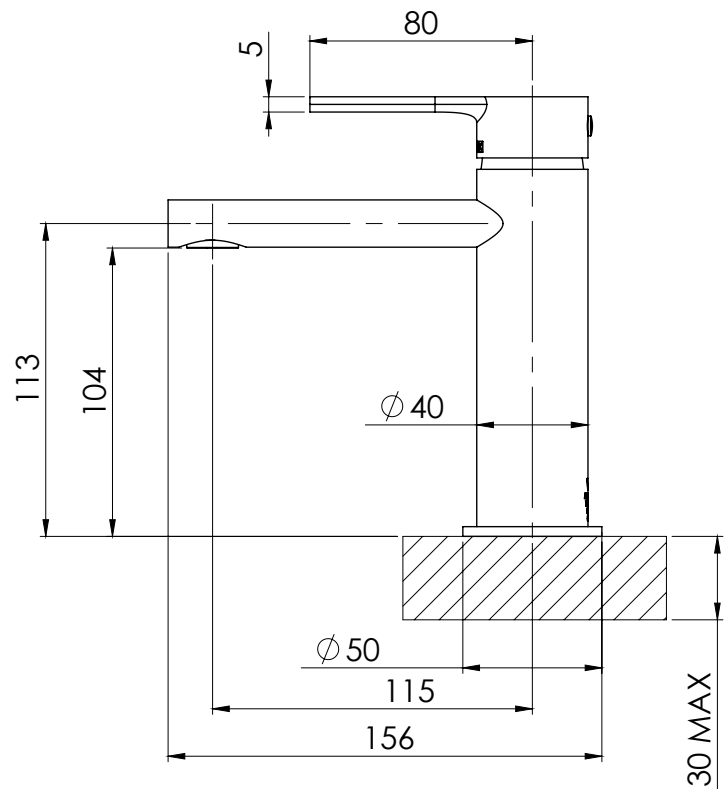
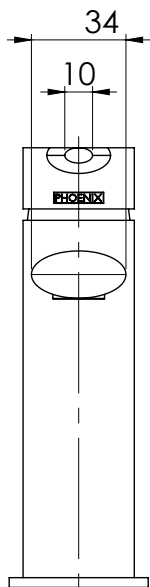

PLEASE [CLICK HERE TO VIEW FULL WARRANTY](#)

While we aim to ensure the specifications shown are correct at time of printing, Phoenix Tapware reserves the right to make modifications without prior notice. Always use the physical product measurements for mark-ups and roughing-in as the line drawing shown may differ from the actual product over time. All measurements are shown in millimetres. Some colours may vary across product types due to differing construction materials. Printed images are a representation only and the colour or finish may vary from the actual product.

www.phoenixtapware.com.au
 03 9780 4200



PHOENIX

SPECIFICATIONS

VIVID SLIMLINE OVAL

BASIN MIXER

PRODUCT CODE:

VV770-40

FINISH:

BRUSHED NICKEL

WELS:

6 STAR - 4.5 LT/MIN



PARTS LIST

1. MIXER HANDLE
2. MIXER BODY
3. MIXER PLATE
4. MIXER DOME
5. GRUB SCREW CAP
6. GRUB SCREW M4X5
7. O-RING 26X2.5MM
8. O-RING 39X3.5MM
9. M8 THREADED ROD
10. M8 NUT
11. FLEXIBLE HOSE (HOT)
12. FLEXIBLE HOSE (COLD)
13. AERATOR
14. 25MM CARTRIDGE
15. CARTRIDGE SLEEVE
16. FIXING PLATE
17. RUBBER FIXING PLATE

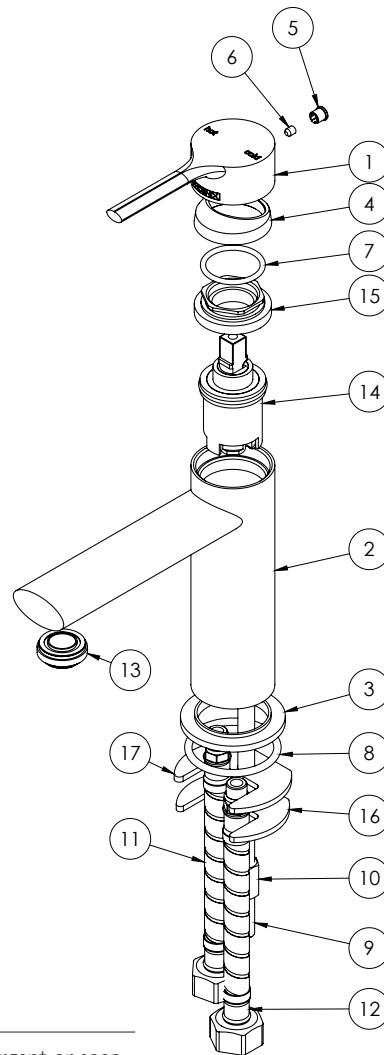

MAINTENANCE AND CARE:

- All surfaces should be cleaned with mild liquid detergent or soap and water.
- Do not use cream cleaners or citrus based cleaning products, as they are abrasive.
- Use of unsuitable cleaning agents may damage the surface. Any damage caused in this way will not be covered by warranty.

PACKAGING INCLUDES

- 1 x Basin mixer
- 1 x AF11 Spanner
- 1 x Installation kit
- 1 x 450mm braided flexible cold hose
- 1 x 450mm braided flexible hot hose
- 1 x Installation instructions
- 1 x Warranty card

PLEASE [CLICK HERE TO VIEW FULL WARRANTY](#)

While we aim to ensure the specifications shown are correct at time of printing, Phoenix Tapware reserves the right to make modifications without prior notice. Always use the physical product measurements for mark-ups and roughing-in as the line drawing shown may differ from the actual product over time. All measurements are shown in millimetres. Some colours may vary across product types due to differing construction materials. Printed images are a representation only and the colour or finish may vary from the actual product.

www.phoenixtapware.com.au

03 9780 4200