

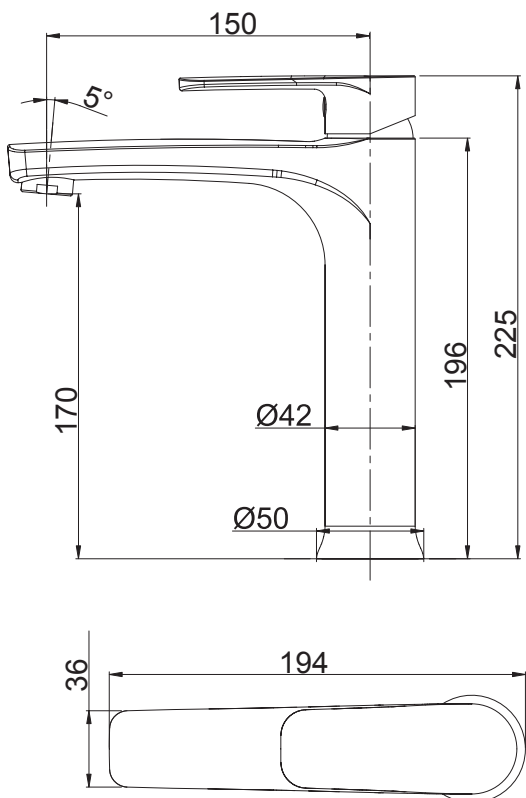



PACE TALL BASIN MIXER

Product Image	Technical Specification
	

Description	Additional Information
<p>Pace Tall Basin Mixer WELS 5 Star / 6 Lpm</p> <p>BM222604 Tall Basin Mixer - Chrome BM222604MB Tall Basin Mixer - Matte Black</p>	<ul style="list-style-type: none"> • 15 Year Replacement Warranty* • 35mm European Ceramic Cartridge • Quality PEX Connection Hoses • Superior Flow Regulator <div style="display: flex; justify-content: space-around; align-items: center;">   </div>

