

TURNER HASTINGS

MADE IN ENGLAND

Delille Basin Stand Installation Instructions

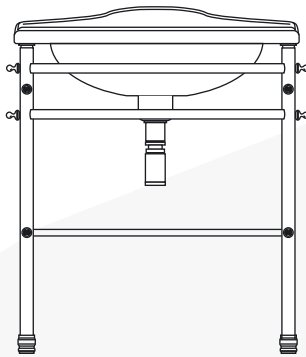

Important Information:

Please check the products for transport damage and that contents are complete before installation.

Consult a qualified plumber if you have any problems installing this product.

Complaints made following installation regarding the above cannot be accepted.

Thank you for purchasing this product.
Before you start check you have the necessary tools for installation.

Before you begin:

⚠ Always handle our products with care and attention.
Ceramic products are brittle, and may chip, crack or break if not handled carefully.
Broken ceramic is extremely sharp.

Take care not to over tighten screws and fittings. Over tightening may lead to breaks or chips in the ceramic.

Before installing the product, please inspect for damage incurred during transport.

Turner Hastings cannot take responsibility for damaged products after or during their installation.

We recommend that the guidance of a qualified plumber is sought throughout the installation process.

Always observe the plumbing and building regulations in the area the product is being installed in.

Turner Hastings reserves the right to amend the design of its products without notice, as specified in the company catalogue.

Note: This Product is not for installation in situations where skirting board width is greater.

Identifying Legs & Parts

Ref	Part	Qty
a	Front Legs	x2
b	Back Legs	x2
c	Side rails (450mm)	x2
d	Shelf	x1
e	Cross -Rail (500mm)	x1
f	Threaded Bars	x4
g	Cross Screws	x4

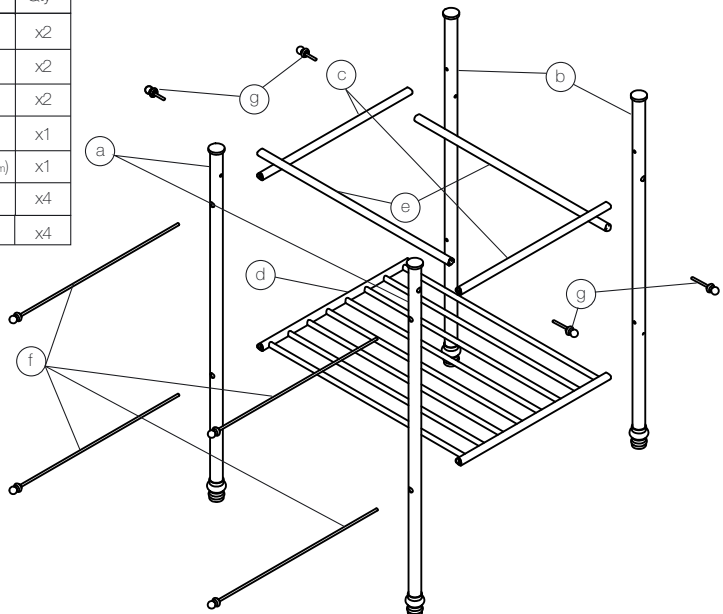

Identifying legs

To identify the back legs from the front legs please locate the thread hole (small holes located on the back legs). The front legs have no thread holes. The back legs should be positioned so that the thread hole is parallel with the front legs and to ensure that the threaded bars will go through (Fig1).

Fig1

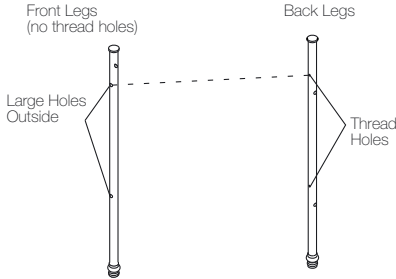
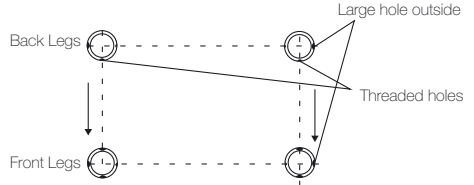
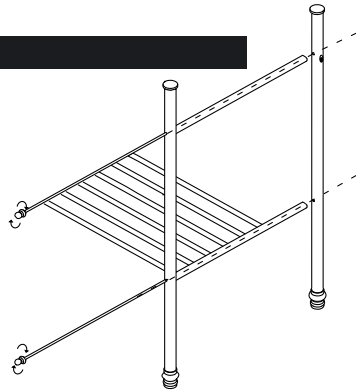

Fig2



Assemble the sides

Align the large hole with the upper and lower side rails, then feed through the screw thread. Tighten the screw thread to the right until it has been screwed in securely.



Assemble the sides

When assembling the other side ensure that the mfront leg and back leg is positioned properly and that the holes are aligned properly. Feed the screw threads through the side rails and fastern the screw threads.

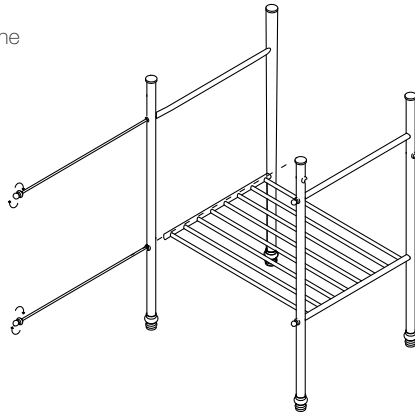

Install the cross bar

Ensure that the holes are aligned with the large hole. Screw the cross screws in the remaining holes.

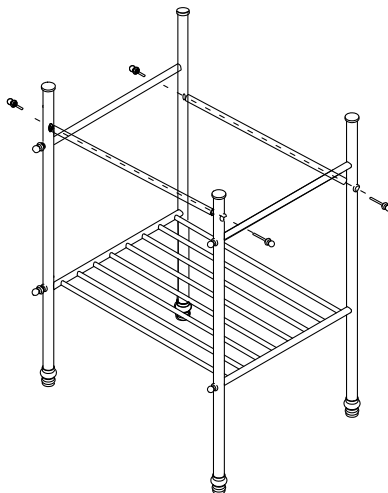

You are now ready to install your basin

Carefully lower the basin into location and check that the product sits level. Fine adjustments can be made by rotating the adjustor sections of the leg (located at the top). Once you are fully happy with the fit of the basin on the stand complete the necessary plumbing in of taps and waste fittings.

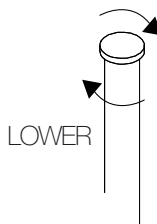
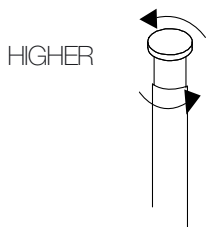

Cleaning and After Care

Metal Finishes should be cleaned with warm soapy water and dried with a soft dish cloth. Under no circumstances should bleach or abrasive cleaning products, polishes, or detergents be used on plated surfaces and in particular should these material be used on the metal finish it is possible that it will be damaged.