



RHEEM COMPACT ELECTRIC

	7 YEAR	47L or 21L	INDOOR/ OUTDOOR
ELECTRIC	CYLINDER WARRANTY ¹	DELIVERY ^{2,3}	INSTALLATION

MOST COMPACT OVER-40L AVAILABLE
670mm height
400mm diameter

COMPACT
390mm height
385mm diameter



The Rheem COMPACT range now features Compact 47 and Compact 25 models, both with the benefit of compact design, for space-limited installations. Wherever space is short but strong hot water delivery is a necessity, trust Rheem Compact to deliver.

COMPACT 47 FEATURES

- Just 670mm high x 400mm diameter
- Dual handed for easier installation
- Storage capacity 50L
- 3.6 kW rating
- 7 Year Cylinder Warranty¹
- Recessed plug fittings

COMPACT 25 FEATURES

- Just 390mm high x 385mm diameter
- The smallest Rheem electric water heater
- Storage capacity 25L
- 2.4 kW, 2.4 kW with power cord or 3.6 kW rating
- 7 Year Cylinder Warranty¹
- Recessed plug fittings

WHY CHOOSE RHEEM?

- Backed by over 70 years of Rheem water heating experience
- Capacities to suit every application and hot water requirement
- Mains pressure water delivery for water that comes on steady, hot and strong!
- Full technical support through Rheem's National Service Network.





DESIGNED FOR EASY INSTALLATION

Rheem COMPACT is specifically designed for a fast and easy installation. Whilst suitable for indoor or outdoor installation, the compact size means it is the unit of choice when replacing water heaters underneath the kitchen bench, in cupboards, or in the laundry.

RHEEM'S INSIDE STORY IS JUST AS STRONG

A ceramic lining, bonded to the inside of the cylinder provides long life protection against the varying water conditions found across Australia, backed by a 7 year cylinder warranty¹.

The Rheem storage cylinder is made from specially formulated steel tough enough to withstand varying water and heating cycle pressures.

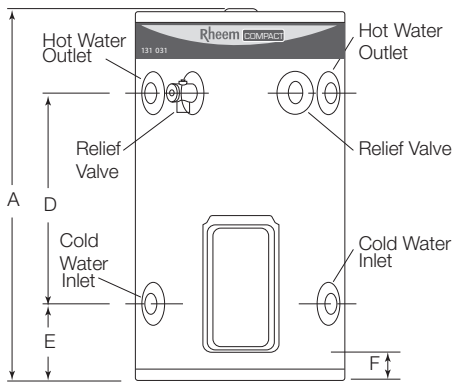

RHEEM COMPACT SPECIFICATIONS			
	Warranty		Model
Rheem Single Element	7 Years ¹		111025
Rheem Single Element Dual Handed	7 Years ¹		191045
Hot Water Delivery	Litres	21 ³	47 ²
Storage Capacity	Litres	25	50
Dimensions	A	mm	390
	B	mm	385
	C	mm	420
	D	mm	130
	E	mm	116
	F	mm	56
	H	degrees	27
	J	degrees	65
kW rating		2.4, 3.6	3.6
Approx. Weight Empty	kg	17	25
Inlet/Outlet Connections	Rp	Rp 3/4	Rp 3/4
Relief Valve Settings	kPa	1400	1400
ECV Setting [#]	kPa	1200	1200
Max. Supply Pressure	kPa		
	With Expansion Control Valve		960
Without Expansion Control Valve		1120	1120

Rheem Compact 47
191045

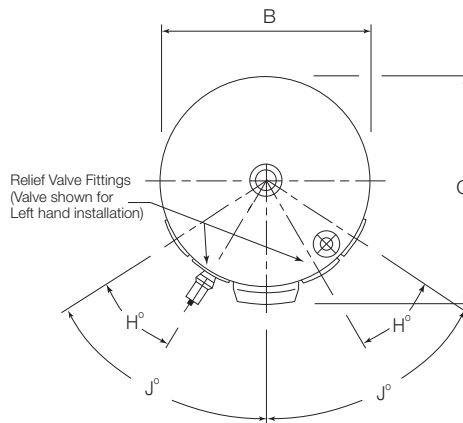

Rheem Compact 25
111025

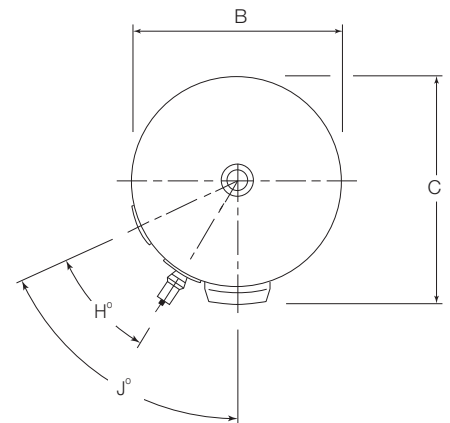

All water heaters operate on 240 volt single phase electricity supply. Plug and lead model suitable for indoor installation only.

ECV not supplied with water heater.

* Including anode cap.

¹ Warranty: 7 Years on Cylinder, 3 Years Labour on Cylinder, 1 Year Parts & Labour warranty on all other components for Domestic (non-Commercial) installations.

² Rated hot water delivery is 40L in accordance with AS/NZS4692.1. Actual delivery is 47L when tested to AS/NZS4692.1.

³ Hot water delivery is 21L when tested to AS/NZS4692.1

Conditions apply. See the Rheem warranty set out in the Owner's Guide & Installation Instructions or view at www.rheem.com.au/warranty.



Rheem Australia Pty Ltd.

1 Alan Street, Rydalmere, New South Wales 2116, Australia
PO Box 7508, Silverwater, New South Wales 2128, Australia.

