

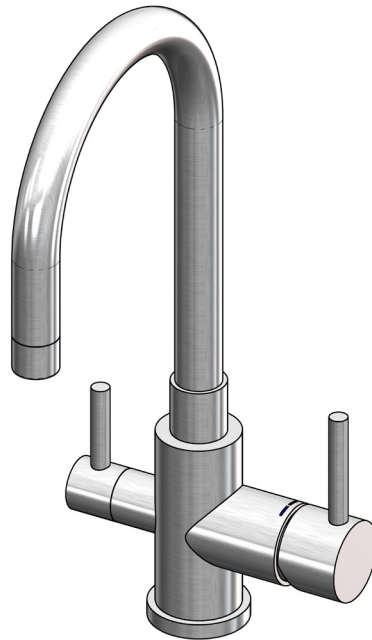

Zip Filter Mixer Tap



AFFIX PRODUCT LABEL HERE

Read these Warnings First

- Please read all installation requirements, installation procedures and precautions before installing any Zip Filter Mixer Tap.
- Never attempt to install any Zip Filter Mixer Tap without reading all of the applicable instructions.
- These products are not intended for use by persons (Including Children) with reduced physical, sensory or mental capabilities, or lack of experience and knowledge, unless they have been given supervision or instruction concerning use of the appliances by a person responsible for their safety.
- Children should be supervised to ensure they do not play with the product.
- The product is for indoor use only and must not be exposed to the elements of nature.
- All plumbing connections must be made in accordance with AS/NZS3500.
- Before installing, ensure there is cold water supply with a minimum working pressure of 70 kPa and a maximum working pressure of 700 kPa. (A 350 kPa limiting pressure valve is supplied)
- Cold water supplied must not exceed 38°C.
- Hot water supplied to the mixer must not exceed 70°C.

Installation Instructions

Install the Filter

The filter (A) should be mounted as close as possible to the front of the cupboard, to allow for ready and easy access during filter changes.

1. Usually the side of the cupboard, near the door, is most suitable.

2. Using the two screws provided, screw the filter head to the inside of the cupboard, allowing 260mm minimum between the underside of the filtration head and any obstructions (shelves, etc.)

3. Write the installation date on the filter cartridge.

4. Align the tabs of the filter cartridge with the filter housing and insert it into the socket. Turn the cartridge a quarter turn to the right until it stops and locks into position. See page 5.

5. Check correct direction of flow on the filter head.

Install the plumbing fittings

Refer to Fig.2. Connect the 1/2" tee piece to the cold water supply.

Fit the two 1/2" nipples to the tee piece.

Connect the 350kPa PLV/double non-return valve to one nipple. **NOTE:** The flow direction arrow is shown on the body of the valve.

Fit the connector and strainer to the other nipple. Check the mesh strainer is orientated as per fig.2.

Fit a connector and strainer to the hot water supply.

Apply plumbing tape where required.

Fig.1

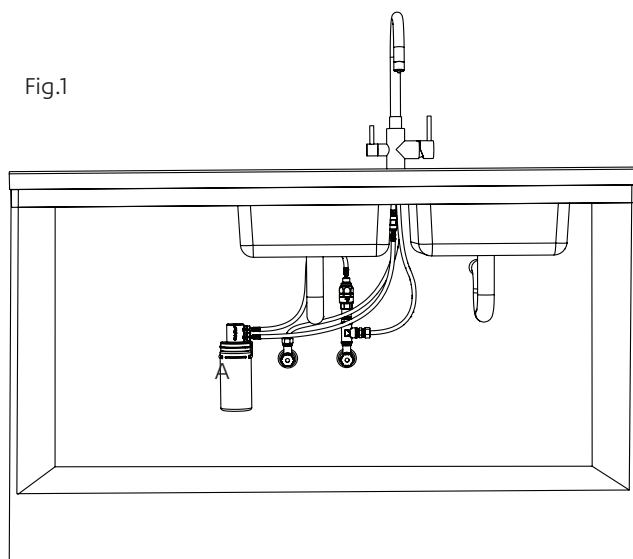
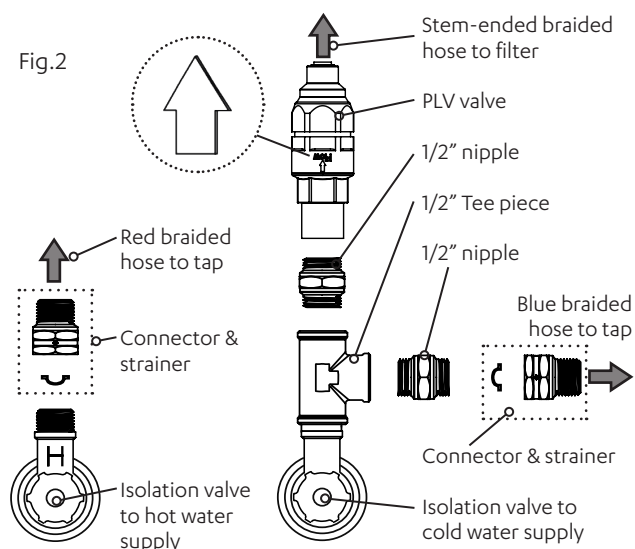

Fig.2



Installation Instructions

Install the Filter Mixer Tap

1. Position the Filter Mixer Tap at the back of the sink where there is a minimum 45 mm wide flat area. Make sure the selected position allows the spout to overhang the sink bowl.

The cutout size is 35 mm. Mark the centre of the new filter mixer tap position on the sink with a centre punch.

2. Drill out the centre of the hole to allow the screw of a sheet metal punch to pass through the sink. Use a 35 mm sheet metal hole punch to neatly open up the hole.

3. Remove the nut and washer from the base of the Filter Mixer Tap, and pass the hoses through the hole until the Filter Mixer Tap sits upright within the hole. When fitting to a thin work surface, use the white plastic stabilising clamp supplied, to improve the support of the tap.

4. Orientate the Filter Mixer Tap so that the activating levers are parallel to the wall of the kitchen. Slide on the washer and nut from beneath the sink, and tighten the nut to secure the Filter Mixer Tap firmly into place.

5. One blue braided and one red braided hose hangs from the bottom of the Filter Mixer Tap. The blue braided hose connects to the tee piece via the connector and strainer, which is connected to the mains isolation valve for cold water, see Fig.3. The red braided hose connects to the mains isolation valve for hot water, via a second connector and strainer.

6. Screw the brass connector with JG fitting into the remaining outlet on the bottom of the mixer tap.

7. Connect one of the stem-ended braided hose from the PLV valve to the inlet of the filter head, see Fig.4.

8. Connect the other stem-ended braided hose from the outlet of the filter head to the straight JG connector at the bottom of the Filter Mixer Tap (see Fig.3 & Fig.4).

Take care when bending braided hoses, to prevent kinking or crushing on a bend. Please be careful to ensure the colour and connection of the braided hoses on the Filter Mixer Tap are correct.

Do not connect the hoses in any other arrangement than that described here. The filter cartridge and the Filter Mixer Tap have directional flow connections that will not work if connected incorrectly. Incorrect installation will void any product warranty.

NOTE: the flow direction of the filter housing is indicated on the filter housing, see Fig.4.

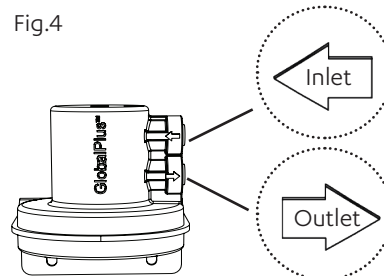
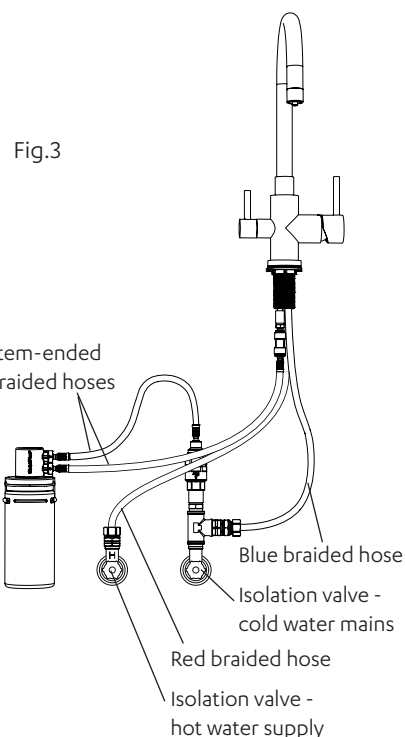

Note: the direction arrows are marked on the filter head.

John Guest fittings

Insertion and removal details for JG fittings using plastic tubing.

1. Cut the tube squarely with a sharp knife or tube cutter. Shake out and remove any swarf or debris.

2. Push this end of the blue tube firmly into the John Guest socket on the (lower) outlet side of the filter head. It must push in at least 10 mm.

3. Test the connection by trying to pull the tube out. If it comes out, re-insert it so that it won't come out when pulled against.

4. To remove the tube, press the collet into the fitting and at the same time pull back on the tube.

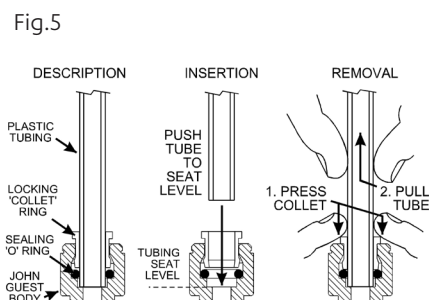

Installation Instructions

Fill the system

1. Turn on the water supply. Check the connections for leaks. Repair any found.

The filter and tubing are full of air until purged, and the filter cartridge requires flushing when first installed.

2. Open the Filter Water lever on the Filter Mixer Tap for a minimum of five minutes, until all of the air has been purged from the system, and the filter cartridge has time to become fully flushed (10L).

Every time the filter cartridge is replaced, repeat this procedure of a five minute flush to flush the new cartridge properly.

NOTE: When flushing the system, some black particles may be released into the water. This is normal. The water will become clear after the first few litres.

Open and flush the cold and hot water supply of the mixer tap.

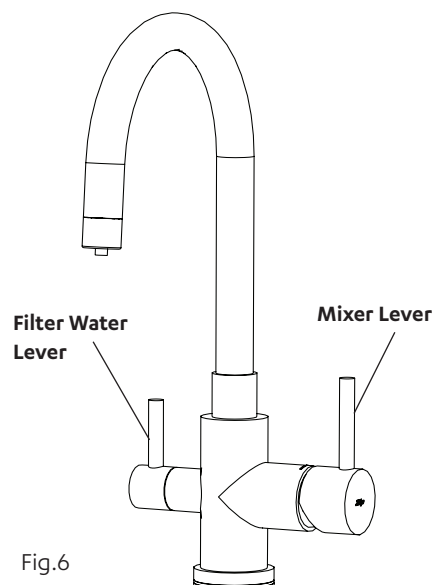

Complete the installation

Leave these instructions with client.

Troubleshooting

Issue	Cause	Recommended solution
No water at outlets	Water not connected	Connect and turn on water
Poor flow at outlet	Blocked filter	Replace filter

Service

All service work must only be carried out by a suitably qualified and experienced service person.

Before calling for service, check the water supply is turned 'ON' and OK.

Call Zip in Australia on 1800 ZIP TAP (1800 947 827) for assistance, service, spare parts or enquiries.

Cleaning

Never use strong, corrosive or abrasive cleaning materials on the Zip Filter Mixer Tap. Wipe the outer surfaces clean with a sponge or a soft cloth using a mild soap and water.



Filter Replacement

Not changing cartridges when required may cause the water to become biologically unsafe. If the Filter Mixer Tap has not been used for more than 12 hours, thoroughly flush water through.

For safe operation, the filter cartridge should be replaced at least every 6-12 months, or earlier if you notice a persistent reduction in water pressure from the tap, or an unpleasant taste or odour in the water. Use only a Zip filter cartridge to match that of your Filter Mixer Tap. Replacement cartridges can be obtained through plumbing suppliers or directly from Zip.

Replacing a Zip Filtration cartridge is as easy as 1-2-3.

1. Unplug the old cartridge
2. Plug in the new cartridge.
3. Purge the filter system by flipping the Filter Mixer Tap lever open (on) for a few minutes until the water runs clear (10 litres).

High sediment water areas

Zip Filter Mixer Tap 94574 is a single filter system suitable for areas in which water supply sediment is not a problem. In areas with heavy sediment contamination, you may wish to replace your 0.2 micron filter with a 3 micron filter, at first filter change. Refer to page 7 for cartridge kit numbers.

FILTER CARTRIDGE REPLACEMENT

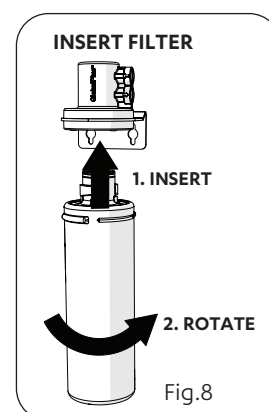
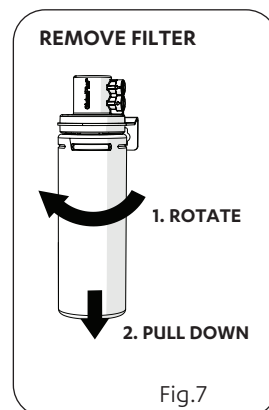

Operation

In the upright position, the tap is off.

For filtered water, rotate filtered water lever 90° forward as shown in Fig.9.

Filtered water will be dispensed (within the rated capacity for) as long as you rotate the lever.

For mixed water, first open the Mixer by swinging the lever 25° away from the centre, then rotate 45° forward or reverse from vertical axis.

Water will continue to flow until the lever is returned to the upright position.

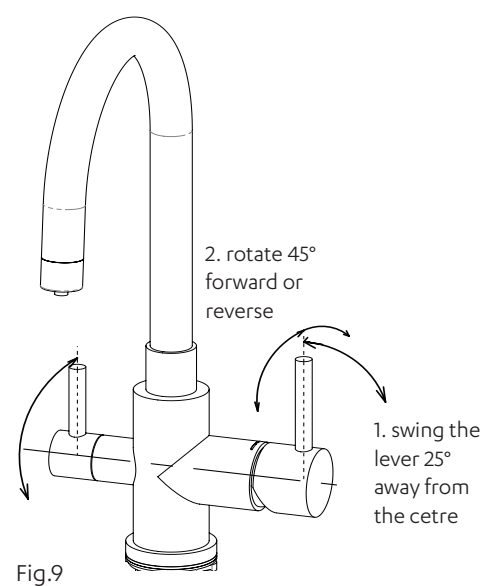

Filter Performance Data - 0.2 Micron

HEALTH CLAIM PERFORMANCE CERTIFIED BY NSF

This system has been tested according to NSF/ANSI Standards 42 and 53 for the reduction of the substances listed below. The concentration of the indicated substances in water entering the system was reduced to a concentration less than or equal to the permissible limit for water leaving the system, as specified in NSF/ANSI Standard 42 and 53.

Substance	Influent Challenge Concentration	Average Influent Concentration	Maximum Acceptable Value‡	Maximum Permissible Water Concentration	Reduction Requirements	Average Effluent Concentration	Average Reduction
STANDARD 42 – AESTHETIC EFFECTS							
Chlorine	2.0 mg/L ± 10%	2 mg/L	4 mg/L / 5 mg/L		≥ 50%	0.05 mg/L	97.4%
Particulate Class I particles 0.5 to <5µm	at least 10,000 particles / mL	6,433,333/L			≥ 85%	47,388/L	99.3%
Bacteriostatic	Unit passes NSF Std. 42 for Bacteriostatic effects.						
STANDARD 53 – HEALTH EFFECTS							
Cyst	Minimum 50,000 / L		99.9% / <1/100 L		99.95%		99.99%
Lead 8.5	0.15 mg/L ± 10%	0.155 mg/L	0.015 mg/L / 0.01 mg/L	0.010 mg/L		0.001 mg/L	98.9%
Lead 6.5	0.15 mg/L ± 10%	0.147 mg/L	0.015 mg/L / 0.01 mg/L	0.010 mg/L		0.0005 mg/L	99.3%

*Tested using flow rate = 1.0 gpm; pressure = 60 psig ± 3; pH = 7.5 ± 0.5; temp. = 20° ± 3°C

‡United States Environmental Protection Agency (USEPA) Safe Drinking Water Act / New Zealand Ministry of Health Drinking-water Standards for New Zealand

This appliance meets the domestic water treatment appliance Standards AS/NZS 3497 and AS/NZS 4348 for the following water process:

Class	Treatment Type	Function	Pass
I	Microbiological Status Bacteriostatic	Will stop bacteria increasing, but will not remove unless II(a) is passed.	✓
II	Microbiological Treatment		
II (a)	Bacteria Removal	Will remove or inactivate bacteria.	N/A
II (b)	Virus Removal	Will remove or inactivate virus.	N/A
II (c)	Protozoa Removal	<i>Cryptosporidium</i> and <i>Giardia</i> . Will not remove or inactivate bacteria unless II(a) and II(b) are passed.	✓
III	Particulate Reduction	Reduces cloudiness.	✓
IV	Taste and Odour Reduction	Reduces tastes and odours.	✓
V	Chemical Treatment	Decreases certain chemicals: - Lead	✓

Legend: ✓ = Pass N/A = Not Applicable

OPERATING SPECIFICATIONS

- Pressure requirement: 10 -125 psi (0.7 - 8.6 bar), non-shock
- Temperature: 35 -100°F (2-38°C)

Model	Flow Rate	Capacity	Cartridge Kit
0.2mic MicroPurity Filter 1S	3.75 Lpm	4163 L	93701
0.2mic MicroPurity filter 1.5S	5.678 Lpm	6813 L	93702
0.2mic MicroPurity Filter 2S	5.678 Lpm	9463 L	93704

System Tested and Certified by NSF International against NSF/ANSI Standard 42 and 53 for the reduction of:

STANDARD NO.42 - STANDARD NO.53 -
AESTHETIC EFFECTS HEALTH EFFECTS

Bacteriostatic Effects	Chemical Reduction
Chemical Reduction	Lead
Taste & Odor	Mechanical Filtration
Chlorine	Cyst
Mechanical Filtration	
Nominal Particulate Class I	

* The term “bacteriostatic” indicates that the system limits the passage or growth of bacteria that may already exist in the incoming water. It does not mean that water leaving the system is safer to drink than water entering the system.



Filter Performance Data - 3 Micron

HEALTH CLAIM PERFORMANCE CERTIFIED BY NSF/ANSI *

This system has been tested according to NSF/ANSI 42 for the reduction of the substances listed below. The concentration of the indicated substances in water entering the system was reduced to a concentration less than or equal to the permissible limit for water leaving the system, as specified in NSF/ANSI Standard 42.

Substance	Influent Challenge Concentration	Average Influent Concentration	Maximum Acceptable Value‡	Maximum Permissible Water Concentration	Reduction Requirements	Average Effluent Concentration	Average Reduction
STANDARD 42 – AESTHETIC EFFECTS							
Chlorine	2.0 mg/L ± 10%	2 mg/L	4 mg/L / 5 mg/L		≥ 50%	0.05 mg/L	90.6%
Particulate Class II particles 1 to $\lt;5\mu\text{m}$	at least 10,000 particles/mL				≥ 85%		97.1%
Bacteriostatic	Unit passes NSF Std. 42 for Bacteriostatic effects.						

*Tested using flow rate = 1.0 gpm; pressure = 60 ± 3 psig; pH = 7.5 ± 0.5; temp. = 20° ± 3°C

‡United States Environmental Protection Agency (USEPA) Safe Drinking Water Act / New Zealand Ministry of Health Drinking-water Standards for New Zealand

This appliance meets the domestic water treatment appliance Standards AS/NZS 3497 and AS/NZS 4348 for the following water process:

Class	Treatment Type	Function	Pass
I	Microbiological Status Bacteriostatic	Will stop bacteria increasing, but will not remove unless II(a) is passed.	✓
II	Microbiological Treatment		
II (a)	Bacteria Removal	Will remove or inactivate bacteria.	N/A
II (b)	Virus Removal	Will remove or inactivate virus.	N/A
II (c)	Protozoa Removal	<i>Cryptosporidium</i> and <i>Giardia</i> . Will not remove or inactivate bacteria unless II(a) and II(b) are passed.	N/A
III	Particulate Reduction	Reduces cloudiness.	N/A
IV	Taste and Odour Reduction	Reduces tastes and odours.	✓
V	Chemical Treatment	Decreases certain chemicals: – Lead	N/A

Legend: ✓ = Pass N/A = Not Applicable

OPERATING SPECIFICATIONS

- Pressure requirement: 10 -125 psi (0.7 - 8.6 bar), non-shock
- Temperature: 35 -100°F (2-38°C)

Model	Flow Rate	Capacity	Cartridge Kit
3mic MicroPurity filter 1.5S	3.75 Lpm	13248 L	93703
3mic MicroPurity Filter 2S	5.678 Lpm	17034 L	93705

System Tested and Certified by NSF International against NSF/ANSI Standard 42 for the reduction of:

STANDARD NO.42 -
AESTHETIC EFFECTS
Bacteriostatic Effects
Chemical Filtration
Taste & Odor
Chlorine
Mechanical Filtration
Nominal Particulate Class II

* The term “bacteriostatic” indicates that the system limits the passage or growth of bacteria that may already exist in the incoming water. It does not mean that water leaving the system is safer to drink than water entering the system.



It is essential that the manufacture’s recommended installation, maintenance and filter replacement requirements be carried out for the product to perform as advertised. See installation Manual for details.

NOTE: While the testing was performed under standard laboratory conditions, actual performance may vary.

Zip Water (Aust) Pty Ltd ABN 46 000 578 727
67-77 Allingham Street, Condell Park NSW 2200
Postal: Locked Bag 80, Bankstown 1885 Australia
P: (+612) 9796 3100 | 1800 ZIP TAP (1800 947 827)
zipwater.com

Zip products described in this publication are manufactured under one or more patents and further patent applications are pending.

As Zip policy is one of continuous product improvement, changes to specifications may be made without prior notice. Images in this booklet have been modified and may not be true representations of the finished goods.

© 2020 Zip Water (Aust) Pty Ltd

