

Brodware

BASIN SET INSTALLATION INSTRUCTIONS

1. Important – Flush water lines on new installations before fitment to avoid damage to valve and blocking of filter or aerator.
2. Measure basin tap hole centres and cut “T” piece to length.
3. Install centre outlet with fibre washer on underside of basin.
4. Remove handles and flanges from taps and fit the spindle assembly to body (see over for installation of ceramic disc cartridge).
5. Connect the “T” piece to bodies - tighten nuts, - push assembly into position connecting “T” piece to centre outlet.
6. Seal around tap bodies with putty or similar.
7. Fit top locknut and washer (where supplied) so that it is flush with top of tap body. Note - not all models use top locknuts. Screw down flanges.
8. Fit handles using the Hex Allen key supplied.
9. Tighten all nuts.

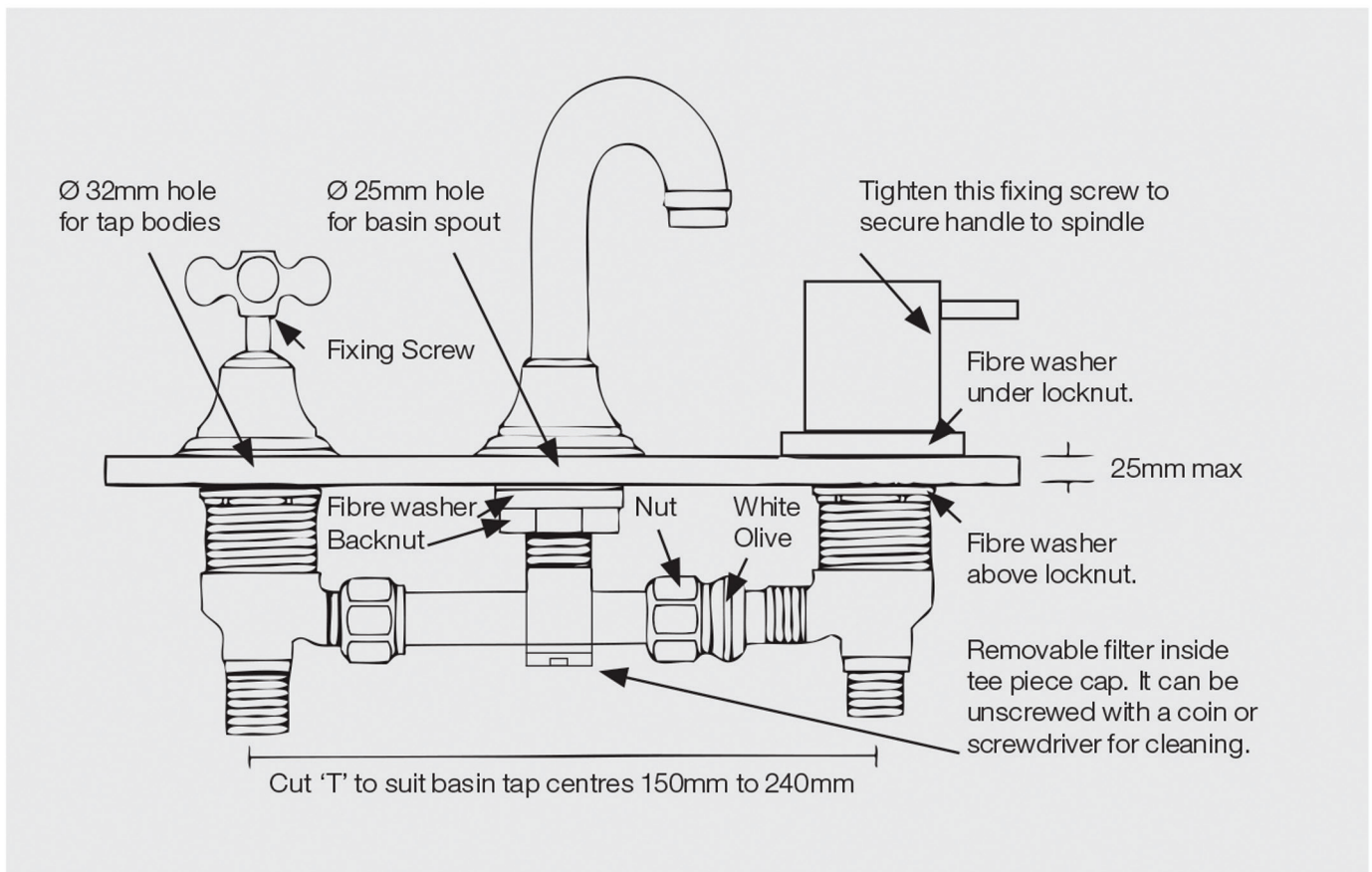

CERAMIC DISC CARTRIDGE INSTRUCTIONS

For use in tap bodies made to Australian Standard AS3500.

1. Note that water inlet temperature not to exceed 50° C and water pressure not to exceed 500 kpa.
 2. Important - Flush water lines on new installations to avoid damage to the valves.
 3. Ensure that the tap seat has a uniform smooth flat surface, square to the tap body face. If seat is worn reseal using a parallel thread tap reseater. Hydroseal® brand is recommended.
 4. **Unscrew and separate cartridge locknut from cartridge body.**
 5. Remove locknut and install cartridge body with 15mm ring or tube spanner until cartridge comes to a firm stop - Do not over-tighten or use multi-grips. Do not tighten cartridge using the spindle.
 6. Fit washer over cartridge body and screw down locknut against face of tap body using a 25mm or 1" ring or tube spanner. Do not use multigrips.
 7. Fit flange. Fit handle using Hex Allen key supplied.
 8. Lever handle taps with ceramic disc cartridge rotate anticlockwise "on" for hot and clockwise "on" for cold. When fitting lever handle cartridges, it is important to first check the position of the lever handle. Lever handles should be fitted so that whilst they point away from each other, they should be parallel. This is done by trial fitting the handles before fitting the locknuts.
- The cartridge can then be slightly tightened or slightly backed off if needs be to ensure handles are parallel.**
9. Seal around bodies to prevent water penetration into wall.
 10. Extended cartridges and locknuts available on request at extra cost.

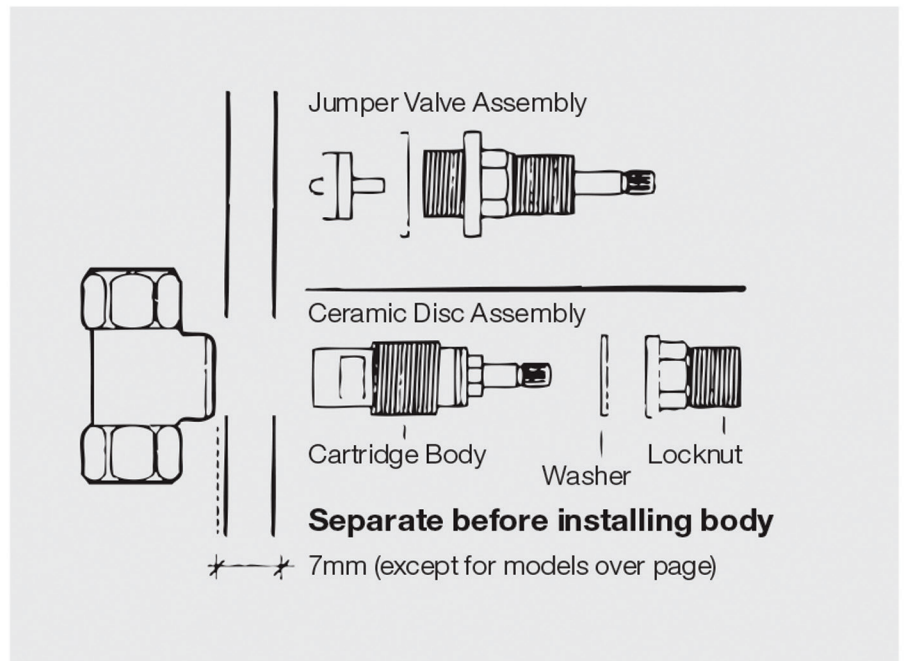

1.7305.03, 1.7349.02, 1.9305.00, 1.9305.02, 1.9308.00, 1.9306.00 AND 1.9306.02

Installation details to be read in conjunction with ceramic disc instructions.

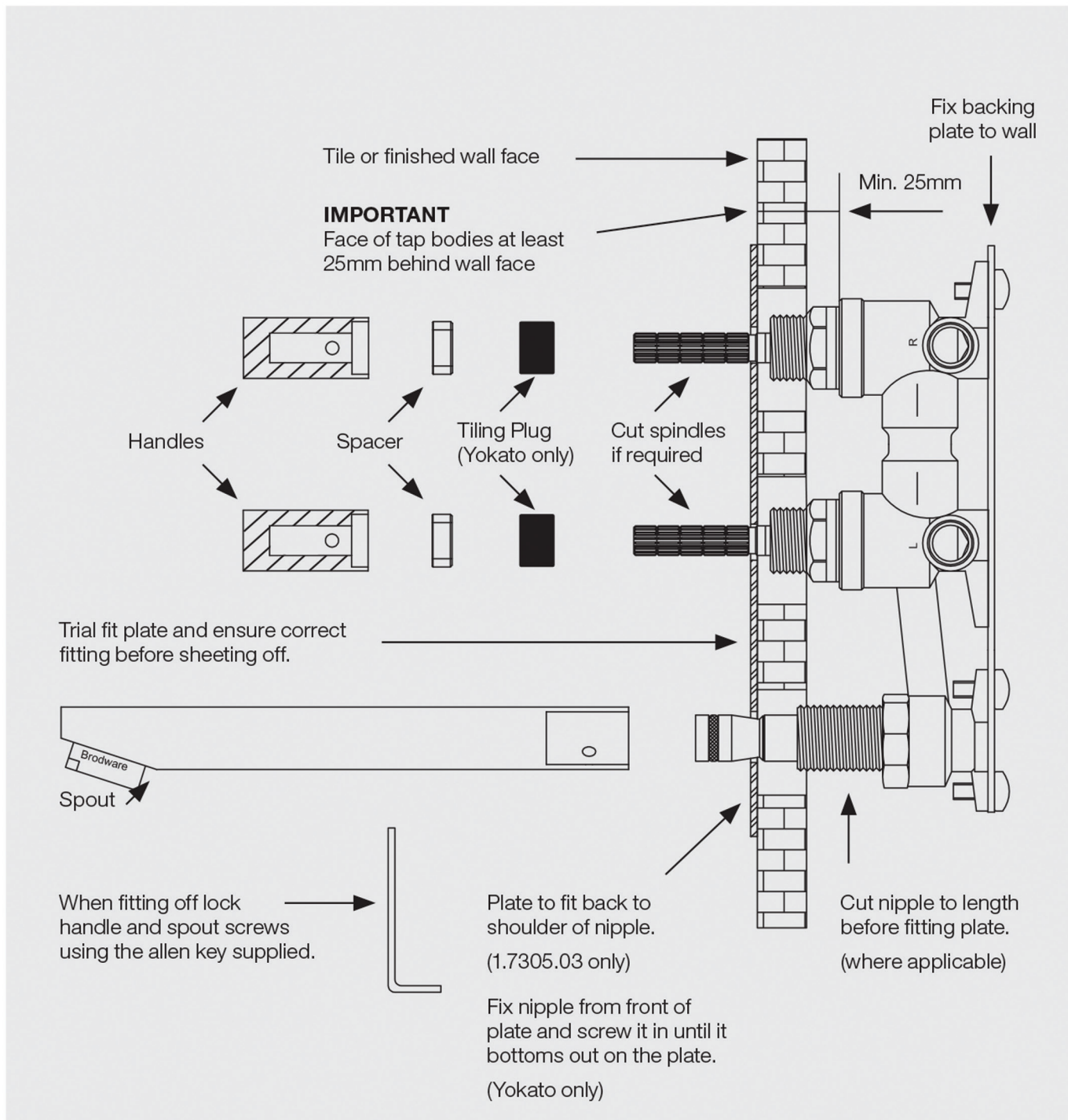

ADDITIONAL INSTRUCTIONS FOR CITY QUE CROSS HANDLE TAPS AND YOKATO

BASIN SET TAPS

Top of flange nut to be flush with top of thread for City Que only.

Add spacer to underside.

Locknut to be underside only.

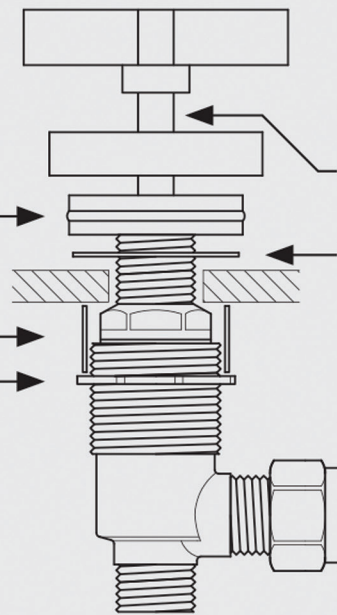

Fix handle to spindle by tightening screw with hex key. Position fixing screw to rear so it is not seen from the front.

Add spacer between handle and flange for Yokato only.

"O" Ring

RECESS TAPS

Cut spindles if required (Yokato only)

Trial fit flange nut and then remove locknut and cut back so it finishes with the top face of the flange nut.

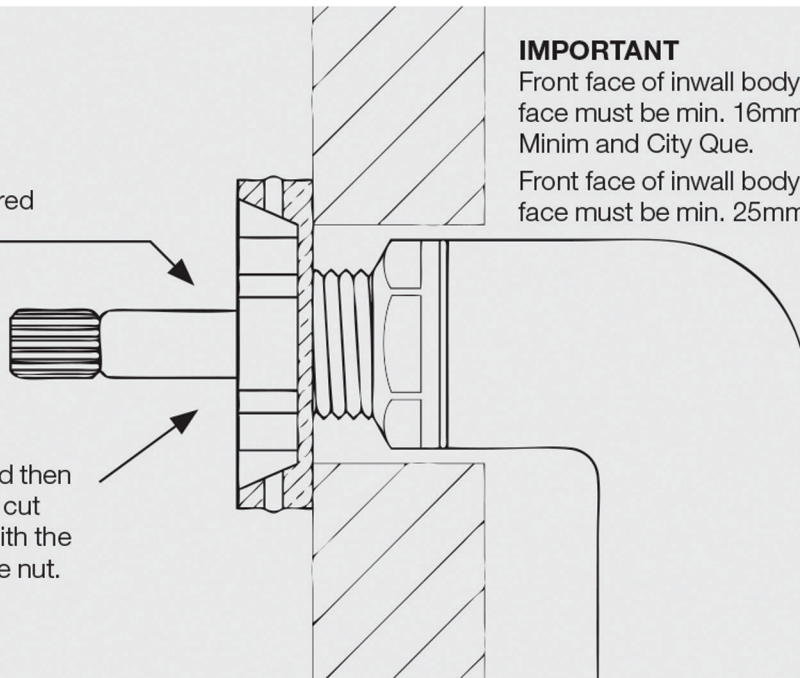

IMPORTANT

Front face of inwall body to finished wall face must be min. 16mm to 25mm for Minim and City Que.

Front face of inwall body to finished wall face must be min. 25mm for Yokato

ADDITIONAL INSTRUCTIONS FOR SQ73, SQ LUX, HALO AND MINIM

BASIN SET TAPS

Top of flange nut to be flush with top of thread.

Add spacer to underside.
(not required for Minim)

Locknut to be underside only.

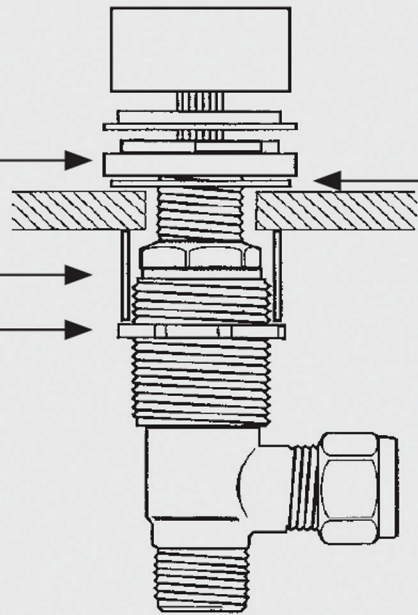

Fix handle to spindle by tightening screw with hex key. Position fixing screw to rear so it is not seen from the front.

"O" Ring

RECESS TAPS

Trial fit flange nut and then remove locknut and cut back so it finishes with the top face of the flange nut.

Trial fit handle and back space and measure clearance between handle and flange. Cut back spindle and re-fit handle with handle fixing hold pointing down so it is not seen from the top.

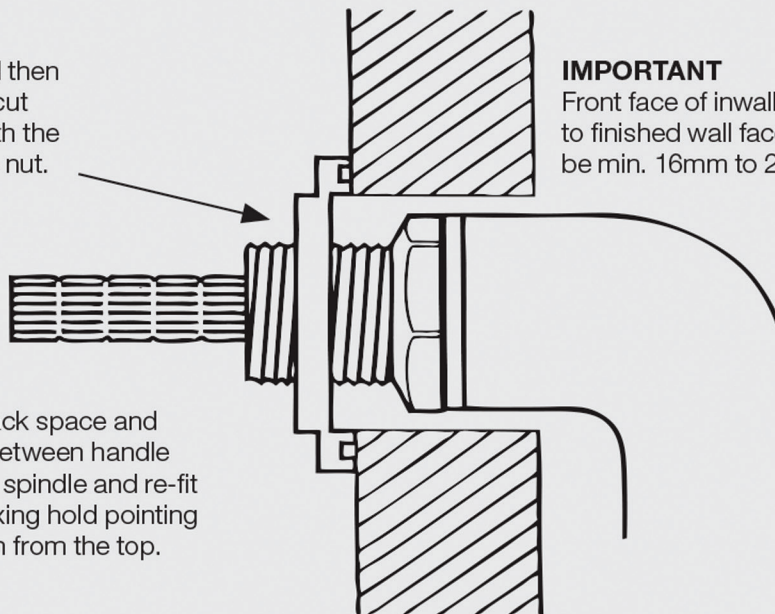

IMPORTANT

Front face of inwall body to finished wall face must be min. 16mm to 25mm.

FLOOR MOUNTED 1.7507.30.0.XX

1. Install G1/2 thread (not supplied) to finish 65mm above finished floor level. Centre and fix fixing flange to floor. Fit flange trim and then fit spout base, secure spout base to flange with grub screws.
2. Screw connection hose to G1/2 thread and secure spout to spout base with cap screws, using allen key supplied.
3. If the floor is not level. The adjustment screws in the fixing flange can be adjusted to ensure the spout is vertical.

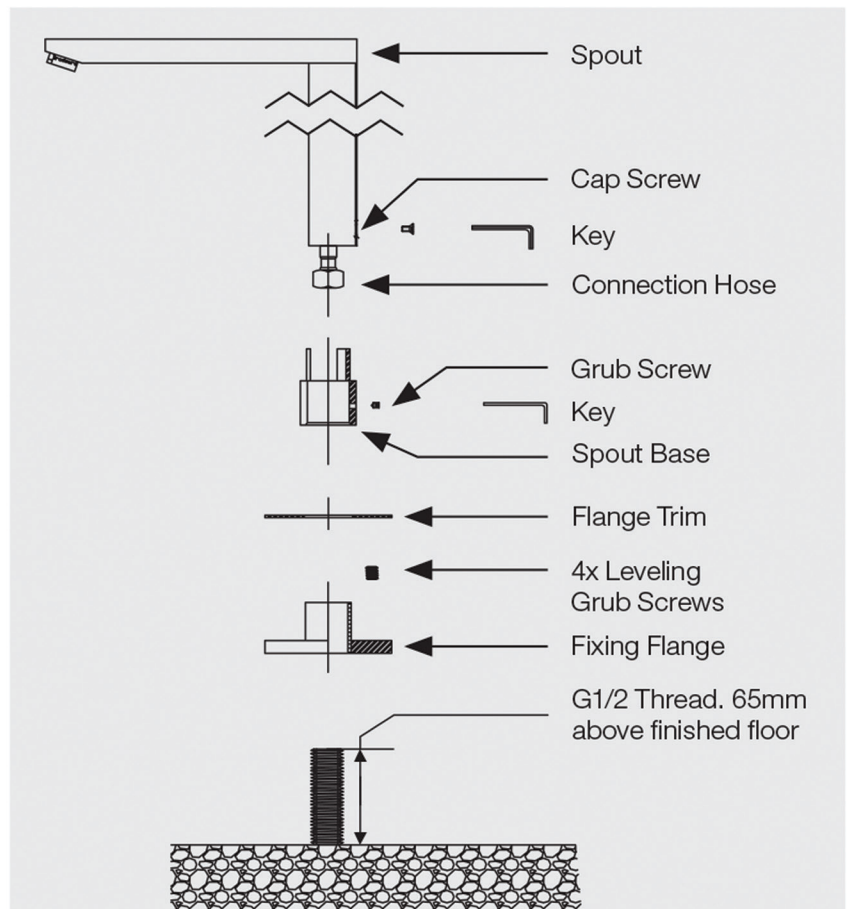

CITY & MINIM TAPWARE WITH BACKPLATES

IMPORTANT

Front face of inwall body to finished wall face must be min. 12mm to 20mm max.

Cut spindles and threaded locknut on MINIM tapware to suit body depth.

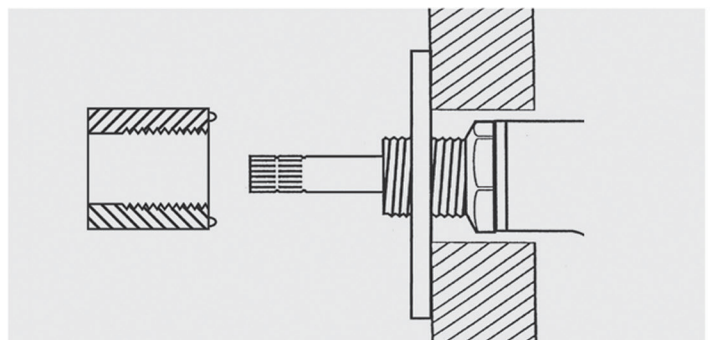

IMPORTANT INFORMATION

IMPORTANT

All tapware and showers to be installed by a licensed plumber and to Australian Standards. Fit tempering and pressure reduction valves where required. Flush water lines before fitment to avoid damage to valve.

WATER TEMPERATURE

Is not to exceed 50°C as per AS3500

WATER PRESSURE

Is not to exceed 500kPa as per AS3500

PRESSURE DIFFERENCE

Hot – Cold water pressure difference is not to exceed 150kPa.



This product is designed to work on high pressure systems only.

This unit cannot be used for unpressurised storage heaters.

SHOWERS

When installing wall showers ensure that the male connecting threads do not damage the flow controller.

something special
something different

FURTHER INFORMATION

For any further information regarding installation, cleaning or replacement components, please do not hesitate to call our customer service on (02) 9421 8200.

ICNMIX | BR3206-02 | 0315

Brodware

Brodware Industries

2 St James Place
Seven Hills NSW 2147
Australia
+61 2 9421 8200
brodware.com