

Venice

VE111500CR
Chrome Wall Mixer

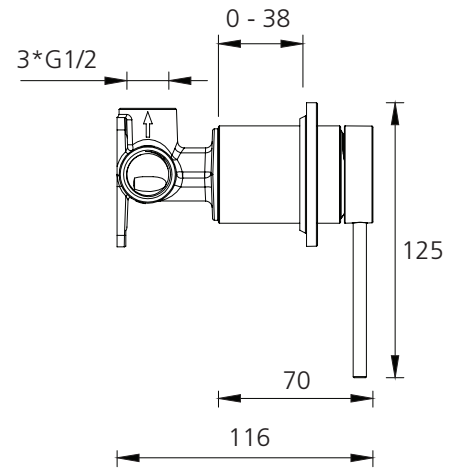
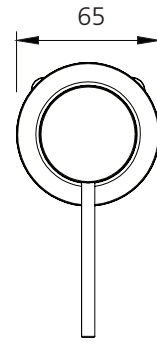

All dimensions in mm

Specifications /

WELs rating	NA
Temperature rating (min / max)	1°C - 65°C
Pressure rating (min / max)	150 kPa - 500 kPa
Finish	Chrome (electroplated)
Materials	Brass body and zinc handle with SUS handle lever
Cartridge size	35mm
Cartridge type	Ceramic disc cartridge
Product weight	0.79kg
Water supply	Mains
Warranty	15 years cartridge, body and finish; 5 years seals, tails, fittings, aerators; 1 year labour (refer to oliveri.com.au)
Maintenance and care instructions	All surfaces should be cleaned with mild liquid detergent or soap and water. Do not use cream cleaners or citrus based cleaning products, as they are abrasive. Use of unsuitable cleaning agents may damage the surface. Any damage caused in this way will not be covered by warranty.

