

INSTALLATION MANUAL

FLOSTOP BUBBLERS

90° Bubbler

TFT8000, TFT8000L

45° Bubbler

TFT8050

Bubbler with separate button

TFT8020

Up Right Bubbler

TFT8050UR, TFT8050URL



Contents

Product Features	3
Product Range	4
Technical Drawings	5
Unit Components	7
Installation Instructions	8
Maintenance	10
Time Adjustment Instructions	12
Water Flow Adjustment	13
Product Warranty	14

Flostop Bubblers by Gentec



The FLOSTOP Soft close, timed flow product range is anti-vandal and has been designed to withstand heavy use in any commercial application for over 1,000,000 cycles of operation.

The hydraulically operated time flow tapware will enhance your facility by providing high-level hygiene and extensive energy and water savings. Varied standard time delays are available. Adjustable time delay of 1 - 40 seconds is supplied with some products.

Timed control features	<ul style="list-style-type: none"> ▶ Adjustable timing from 1 - 40 Seconds
Installation and servicing	<ul style="list-style-type: none"> ▶ For durability please ensure to install all parts including strainers and flow regulators.
Usage features	<ul style="list-style-type: none"> ▶ Adjustable timing via adjustment screw for 1 - 40 seconds
Application	<ul style="list-style-type: none"> ▶ Commercial premises, Healthcare accessible areas, child care facilities, Sports facilities.

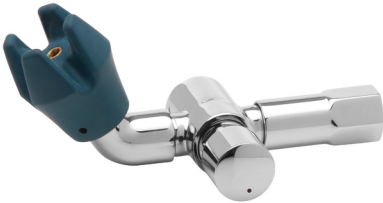

Product Range

TFT8000 / TFT8000L	TFT8020
90° BUBBLER WITH PROTECTIVE GUARD	BUBBLER WITH SEPARATE PUSH BUTTON
	
TFT8050	TFT8050UR / TFT8050URL
45° BUBBLER WITH PROTECTIVE GUARD	UP RIGHT BUBBLER WITH PROTECTIVE GUARD
	

*Use 350Kpa pressure reducing valve for extended life and better operation

TFT8000

90° BUBBLER WITH PROTECTIVE GUARD

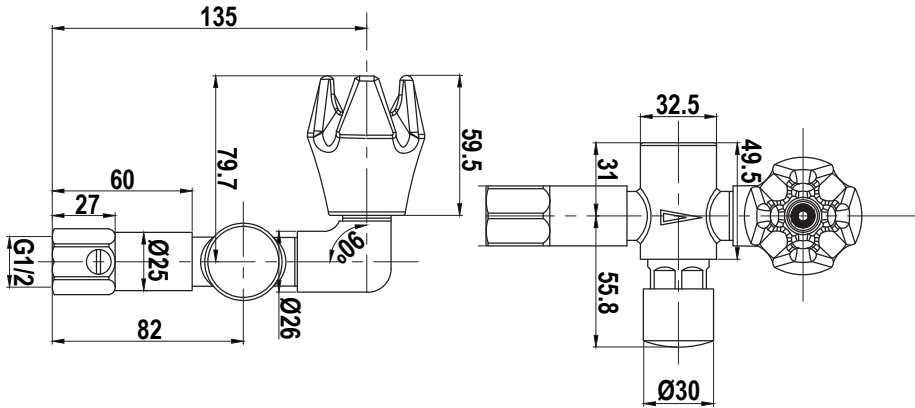

TFT8020

BUBBLER WITH SEPARATE PUSH BUTTON

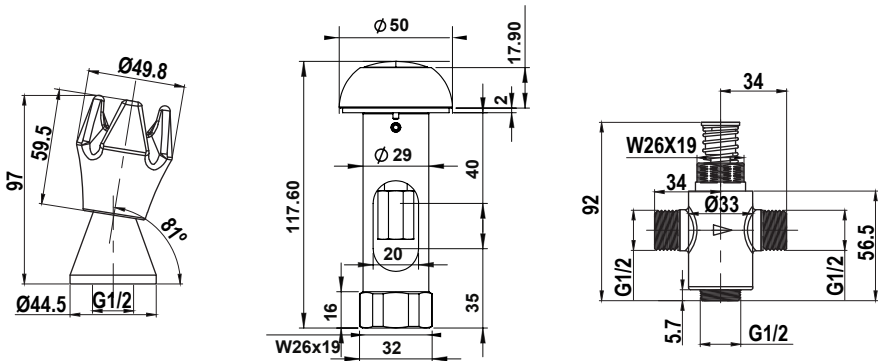

*Regular service must be carried out on the product to avoid product failure.

Technical Drawings

TFT8050

45° BUBBLER WITH PROTECTIVE GUARD

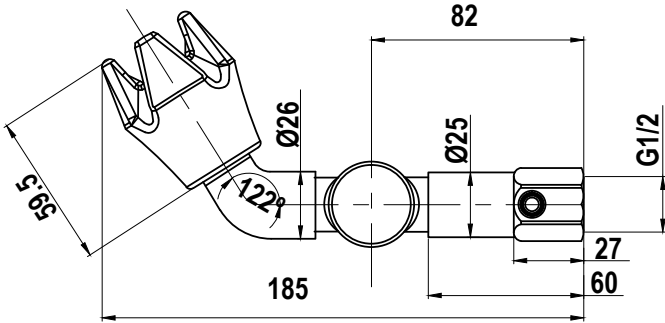

TFT8050UR

UP RIGHT BUBBLER WITH PROTECTIVE GUARD

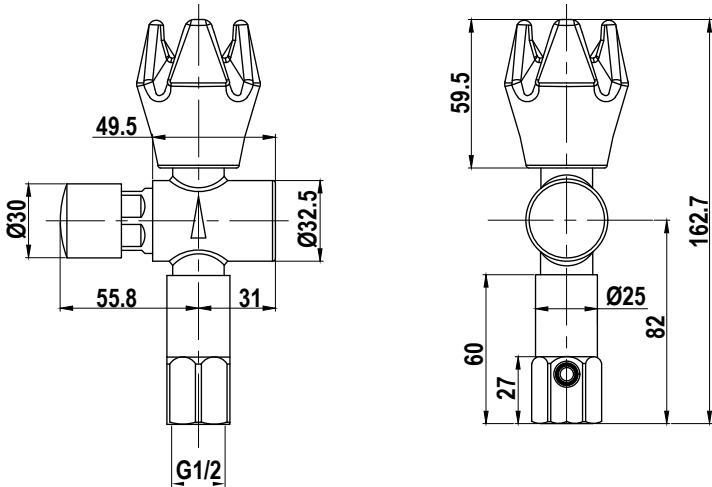

*Use 350Kpa pressure reducing valve for extended life and better operation

Unit Components

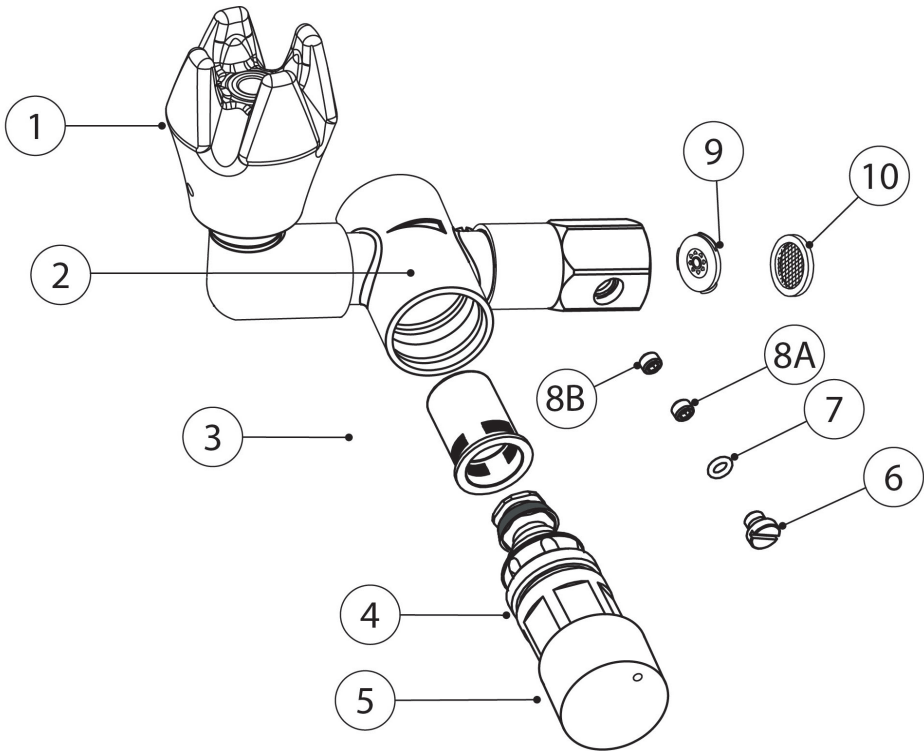

No.	Description	Qty
01	Bubbler Guard	1
02	Body	1
03	Flow Cup	1
04	Cartridge	1
05	Handle	1
06	Cover Screw	1

No.	Description	Qty
07	O Ring	1
8A	Locking Screw	1
8B	Screw for water control adjustment	1
09	Flow Regulator	1
10	Strainer	1

***Regular service must be carried out on the product to avoid product failure.**

Installation Instructions

BUBBLERS

TFT8000, TFT8050, TFT8050UR, TFT8050URL

For all Units:

1. Flush the new pipe prior to installation.
2. Bubblers should be installed with isolating stop tap valve.
3. Install the Flow regulator and place the strainer in the inlet connection before screwing the valve to the water inlet.

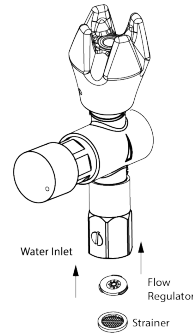
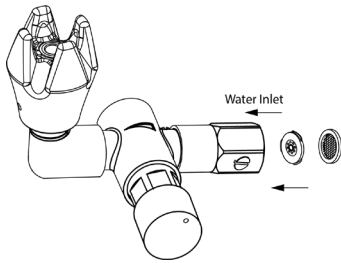

4. Screw the bubbler to the water inlet.

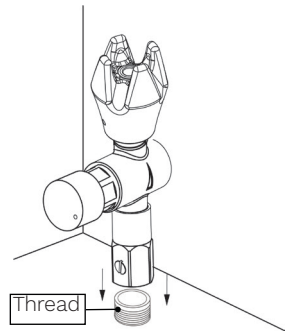
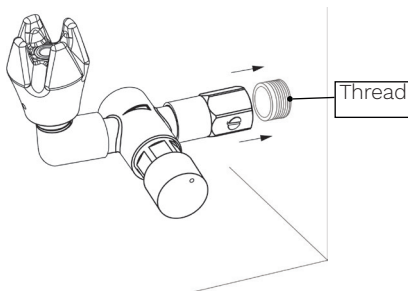

Important Information

We do not recommend dismantling the internal parts of the tapware set. The tapware are individually factory assembled and tested to give the best performance.

5. The drinking taps are fitted with a flow regulator. When applying thread tape or sealant to the inlet, ensure the opening is not obscured.
- * Failure to do so may restrict or block the flow regulator affecting the flow of water.

***Use 350Kpa pressure reducing valve for extended life and better operation**

BUBBLER WITH SEPARATE PUSH BUTTON

TFT8020

1. Allow a 32mm cut-out hole to fit the push activated button mechanism. Drill a 3mm hole to fit the Anti-vandal pin. This should be fixed to prevent movement of the button.

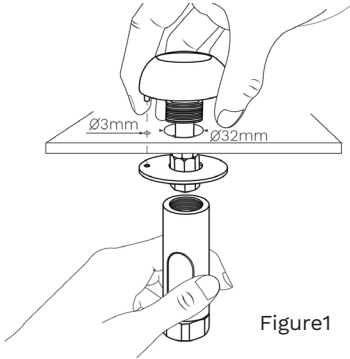

Figure1

2. The timed flow valve should be fitted to the push button assembly to install the bubbler outlet.

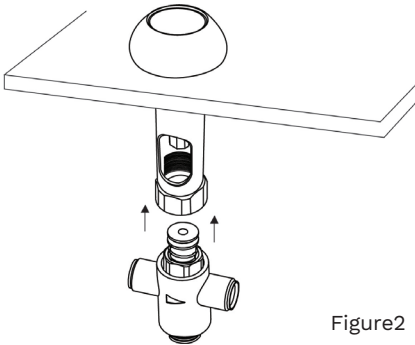
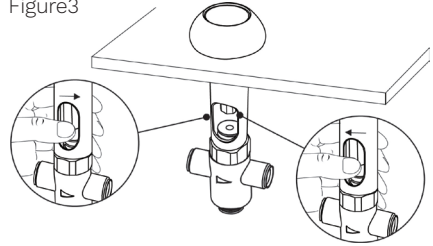

Figure2

3. Adjust in the cartridge length to suit the basin surface thickness. (See Figure 3)

Figure3



4. Fit the flexi hoses (not provided) to the water inlet and outlet. Ensure the arrow on the button body is aligned with the water flow direction. (Pointing to the water outlet).
5. To install the bubbler outlet allow a cut out no greater than 38mm and connect the flex hose from the valve.

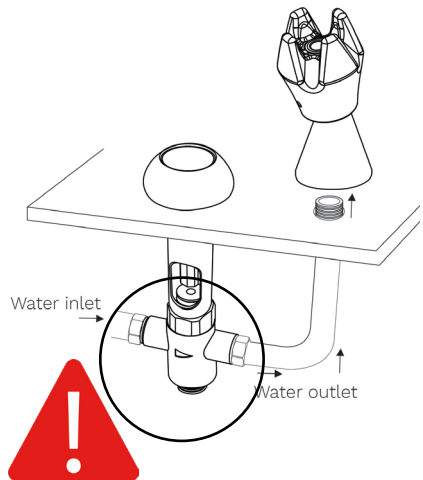

- **Note: Ensure the arrow in the valve body is facing the connection to the water Outlet.**

***Regular service must be carried out on the product to avoid product failure.**

Maintenance

Important Note

For adequate maintenance, please unscrew and clean the strainer, then proceed to flush the line before putting back the strainer.

O Ring Kit service

For the following steps, a qualified plumber must be in charge of the maintenance and handling of the tapware in order to keep product Warranty. The damage on parts after dismantling a product would not be covered by the warranty.

First start by shutting off the main water supply.

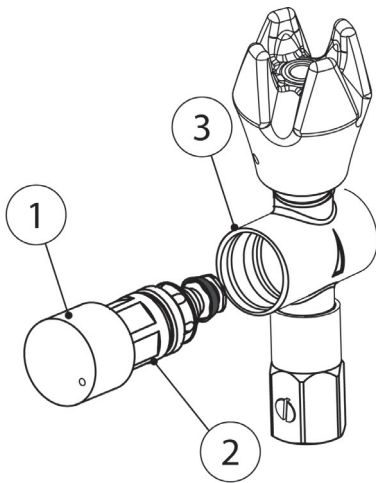

No.	Description	Qty
01	Handle	1
02	Cartridge	1
03	Bubbler Body	1
04	Stem	1
05	Head Valve	1
06	Washer Gaco	1
07	O-Ring	1
08	Crown Ring	1
09	O-Ring	1
10	Stopper	1
11	Washer Gaco	1

Note

- The “O” Ring Kit consists of #6, #7, #9, #11

*Use 350Kpa pressure reducing valve for extended life and better operation

1. Remove the head valve using a shifter on the flats and remove the cartridge. (Figure 1)
2. Undo the stopper (10)
3. Set aside the crown ring (8)
4. Set aside the head valve (5) from the stem
5. Remove the washer Gaco (6) from the head valve (5) and replace with the new washer gaco (6)
6. Remove the Gaco (11) from the stopper (10) and replace it with the new washer gaco (11)
7. Remove the "O" Ring (9) and replace it with the new "O" Ring (9)
8. Remove the "o" Ring (7) and replace it with the new "o" Ring (7)
9. Using the existing crown ring (8) place it back into the head valve (5)
10. Place the stem (4) through the head valve (5)
11. Apply a drop of Loxeal to the thread of the stem (4)
12. Replace the stopper (10), ensure the "o" Ring (9) is in place, then tighten the stopper (10). Do not overtighten.
13. Fit the cartridge and handle back into the body, and tighten. Do not overtighten.

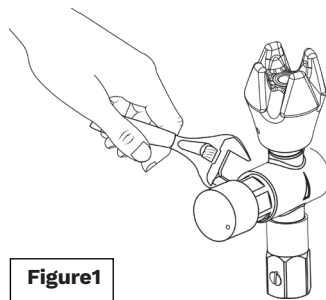
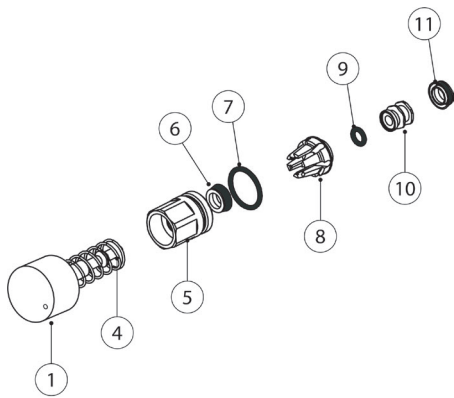

Figure1



Important Information

The damage on parts after dismantling a product would not be covered by the warranty.

***Regular service must be carried out on the product to avoid product failure.**

Time Adjustment

ADJUSTABLE CARTRIDGE (0 TO 40 SECONDS)

This option is suitable for the following references: TFT8000, TFT8050, TFT8050UR, TFT8050URL

The adjustable cartridge used is a 30mm diameter handle with a small 3mm hole in the front of the handle. The hole in the handle has a grub screw for adjusting the run time.

- To adjust the timing, you will need to use the allen key provided or you need a 1.2mm allen key to adjust the timing.

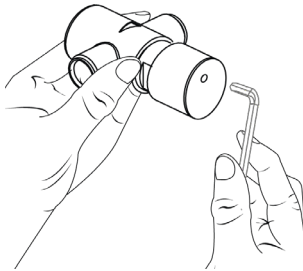

- Turning the screw in clockwise will reduce the run time.

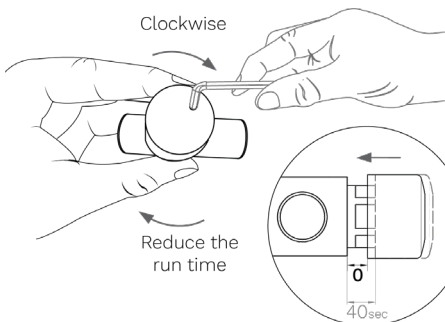

- Turning the screw anti clockwise will increase the run time

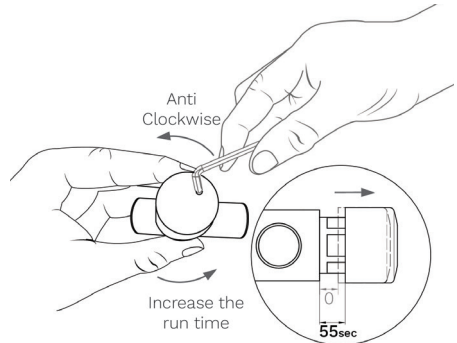

Fixed Timing Adjustment

Please contact GENTEC before changing flow cups

Our Flostop range is available in the following fixed timing options

These options are available upon request and are factory installed. *Refer to the chart below

Changing the flow cup yourself may void the product warranty.

FCC.	Description
TFT9050	Flow cup 4 - 6 Sec
TFT9052	Flow cup 8 - 12 Sec
TFT9053	Flow cup 12 - 16 Sec
TFT9054	Flow cup 40 Sec

*Use 350Kpa pressure reducing valve for extended life and better operation

WATER FLOW ADJUSTMENT

This option is suitable for the following references: TFT8000, TFT8050, TFT8050UR

To adjust the water flow:

1. Unscrew the top cap (6) (7)
2. Remove the locking screw (8A) and adjust the flow with adjustable screw (8B) using a 3mm Allen key.
3. Screw the top cap (6) (7) back.



Do not remove the water control screw (8B) from the body

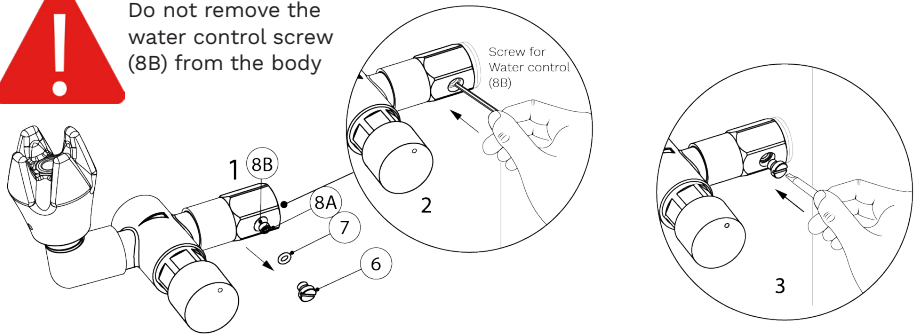

- Turning the screw clockwise will reduce the water flow.
- Turning the screw anti clockwise will increase the water flow.

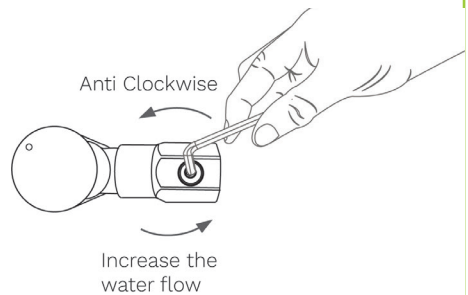
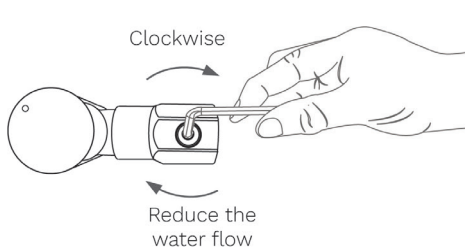

***Regular service must be carried out on the product to avoid product failure.**

Warranty

GENTEC PRODUCT QUALITY WARRANTY

You have purchased a quality product from GENTEC Australia Pty Ltd ABN 581552 50285). This product is covered by a 10 year replacement product warranty and a 24 month warranty on spare parts and labour.

1. Warranty

1.1 This warranty is given by the Principal subject to the terms and conditions set out in this document.

1.2 The Principal warrants that the Goods are free from defects in materials and workmanship for the time period specified for the Goods in the Product Index. If Your Goods are found to be defective within that time, we will repair or replace the Goods.

1.3 This warranty does not cover accidental damage, wear and tear, consequential or incidental loss, or any damage caused by You, including if the Goods were not installed in accordance with the manufacturer's instructions, the PCA and AS/NZS3500.

1.4 You are required to service the Goods regularly. Failure to do so may cause this warranty to be voided.

2. Procedure

2.1. If you consider that the Goods are defective, you must cease use of the Goods immediately and provide notice to the Principal in writing as soon as is reasonably practicable after discovering the alleged defect.

2.2. The notice referred to in clause 2.1 must state the following:

2.2.1 the alleged defective Goods;

2.2.2 what the alleged defects are;

2.2.3 where the Goods are located;

2.2.4 when the Goods were purchased

2.2.5 the invoice number relating to the purchase of the Goods;

2.2.6 whether the main water to the unit is able to be turned off;

2.2.7 include pictures of the alleged defect; in a reasonable time.

2.2.8 completed credit card authorisation in the form set out in Schedule 2 to these conditions accepting liability in accordance with clause 2.6 if the product is not faulty.

2.3 The Principal will, on receipt of a notice in accordance with clause 2.2, issue a case number for the investigation of the alleged defective Goods.

2.4 In the event that the Goods are to be returned to the Principal You may bring or send them to one of our service locations or sites. If the cost of returning the goods to us is significant because of the nature of the failure or because of the size or height of the goods, the Principal will collect the goods from you within a reasonable time of You providing notice in accordance with clause

2.2. If the cost of returning the Goods to us is not significant, you are responsible for this cost (although, you are entitled to compensation for reasonably foreseeable costs incurred because of the defect, including the cost of returning the goods to us for repair, replacement or return).

2.5 In the event that the Principal or its agent are required to inspect the Goods at the location of their use or storage, You will, on reasonable notice, allow the Principal to inspect the allegedly defective Goods at the location of their use or storage.

2.6 You are responsible for Your expenses relating to a warranty claim, except as otherwise provided for in this document. If the Principal is required to attend Your site to inspect the Goods, and it is found that there is no defect or the defect has been caused by the circumstances listed in clause 1.3, You will be responsible for the Principal's reasonable costs of attending Your site. Where reasonably possible, we will notify you to give you the option of paying for a repair or replacement

***Use 350Kpa pressure reducing valve for extended life and better operation**

(however, we have no obligation to do so). We will also provide you with all relevant information associated with obtaining a repair or replacement of the good (including the costs involved and how the repair or replacement will be performed).

2.7 If the Principal agrees that the Goods are defective, they will be replaced or repaired within a reasonable time.

2.8 You have a duty to mitigate your loss in relation to a warranty claim. You must notify the Principal of major failures of the Goods within 3 business days of you becoming aware of such major failure. If you fail to notify us within this timeframe, then we disclaim all liability for consequential or indirect loss as well as losses of revenue or profits.

2.9 For the avoidance of doubt, it is in the Principal's sole discretion as to whether or not the Goods are defective and therefore covered by the warranty provided in this document. Any invoices for services or replacement products will not be paid for by the Principal without prior written authorisation.

3. Mandatory Warranties

3.1 The Goods come with guarantees that cannot be excluded under the Australian Consumer Law. You are entitled to a replacement or refund for a major failure and compensation for any other reasonably foreseeable loss or damage. You are also entitled to have the Goods repaired or replaced if the Goods fail to be of acceptable quality and the failure does not amount to a major failure.

4. Exclusion of Warranties and Limitation of Liability

4.1. Except as may be set out in this document and the Quote, the Principal make no express warranties or representations in relation to the Goods or their delivery.

4.2. To the full extent permitted by law, the Principal:

4.2.1 excludes all implied warranties and conditions under statute or general law as to merchantability, description, quality, suitability, fitness for purpose or otherwise;

4.2.2 is not liable for loss of profit, indirect,

consequential or incidental loss, damage or injury in connection with the Goods;

4.2.3 is not liable for the labour costs associated with replacing the Goods;

4.2.4 is not be liable for any transport or freight costs in relation to any warranty claim and the repair or replacement of the Goods;

4.2.5 limits its liability in connection with the Goods (however arising, whether in tort, contract or otherwise) at its option and sole discretion to:

4.2.5.1 replace the Goods or the supply of its equivalent;

4.2.5.2 repair the Goods;

4.2.5.3 pay for the cost of replacing the Goods or acquiring their equivalent; or

4.2.5.4 pay for the cost of having the Goods repaired.

4.3 The warranties given by the Principal will not apply in the event of defects, failures or other matters regarding the goods where due to:

4.3.1 an act, default, omission or representation made by some other person, excluding Gentec or its manufacturer (for example, damage caused by the misuse or mistreatment of the good by the customer or someone else);

4.3.2 without limitation to (4.3.1) above, a failure to install the goods in accordance with any plumbing codes of practice prescribed by an Australian Federal or State Government body or organisation (including regulators), any plumbing codes of practice generally or any guidelines or instructions issued by the Principal in relation to the Goods; or

4.3.3 a cause independent of human control that occurs after the goods left our control.

4.4 Any of the warranties given by the Principal may be voided by failing to comply with the directions set out in the various user manuals or other instructional material provided to You by

***Regular service must be carried out on the product to avoid product failure.**

the Principal in relation to specific Goods.

4.5 However, nothing in this clause will prevent You from exercising any rights which You may have under the Competition and Consumer Act 2010 or any other law which cannot by law be excluded or modified by agreement.

5. Notices

5.1 Any notice in connection with this document must be given in writing.

5.2 Any notice in connection with this document is taken to be received:

5.2.1 if hand-delivered, on delivery;

5.2.2 if faxed, at the local time (in a place of receipt of that fax) which then equates to the then time at which the fax is sent as shown on the transmission report which is produced by the machine from which that fax is sent and which confirms transmission of that fax in its entirety unless that local time is not a Business Day, or is after 5pm on a Business Day, in which case that communication will be deemed to have been received at 9am on the next Business Day;

5.2.3 if emailed, at the local time (in a place of receipt of that email) which then equates to the then time at which the email is sent as shown on the transmission report which is produced by the computer from which that email is sent and which confirms transmission of that email in its entirety unless that local time is not a Business Day, or is after 5 pm on a Business Day, in which case that communication will be deemed to have been received at 9 am on the next Business Day; and

5.2.4 if posted, seven (7) days after being placed in the post; unless a later date is specified in it, and takes effect on the date it is taken to be received.

5.3 The address for any notice to be delivered to the Principal is as follows:

**Unit 6 20-28 Ricketty St,
Mascot, Sydney, NSW 2020**

info@gentecaustralia.com.au

www.gentecaustralia.com.au

P: +612 9319 4422

F: +612 8088 7635



MAR-IM-FLOT01-MB-041219