

# HOME DATA SHEET

## B1000 Square Slimline



### Billi B1000 with Square Slimline Dispenser

Instant filtered water on tap. The B1000 offers the convenience of filtered still drinking water along with elegant functional design. The B1000 is ideal for cooking & food preparation and drinking water filtration.

Supplied standard with 994052 sub-micron filtration from BWT to deliver the freshest tasting water and ensure the health of your family & guests.



Square Slimline Dispenser

Underbench Filter Housing

### Features



UNLIMITED  
FILTERED  
WATER



SPACE SAVING  
DESIGN



RANGE OF  
FINISHES



AUSTRALIAN  
DESIGNED &  
MADE



EASY  
INSTALLATION

## PRODUCT SPECIFICATIONS

Water type	Product code	Model name	Dispenser	Suggested usage
	911000S	B1000	Square Slimline	<ul style="list-style-type: none"> <li>• Drinking water filtration</li> <li>• Cooking &amp; Food preparation</li> </ul>

### Accessories

**992130** - Square Slimline Spout Extension\*

**992810** - Slimline Font

**990724** - Tubing Extension Kit for Slimline 2mtrs



\*available in chrome, brushed and matte black only

### Finishes

#### Standard Finishes

CH - Chrome	BR - Brushed
MB - Matte Black	MW - Matte White

#### Special Order Finishes

RG - Rose Gold	BRG - Brushed Rose Gold	GM - Gun Metal Grey
PL - Platinum	UB - Urban Brass	

Add the Finish code to the Product Code to finalise your specification, eg. 911000SMB

# TECHNICAL DRAWING & INSTALLATION REQUIREMENTS

## PRODUCT DIMENSIONS

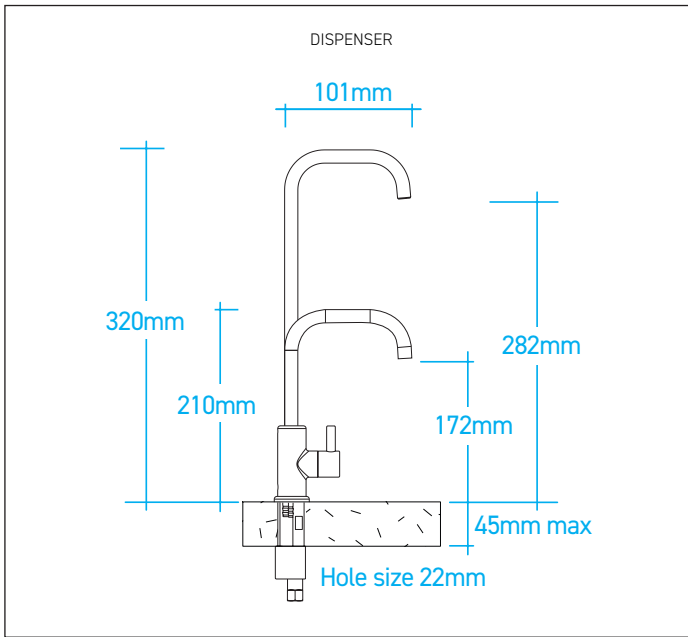

## PREFERRED INSTALLATION LAYOUT

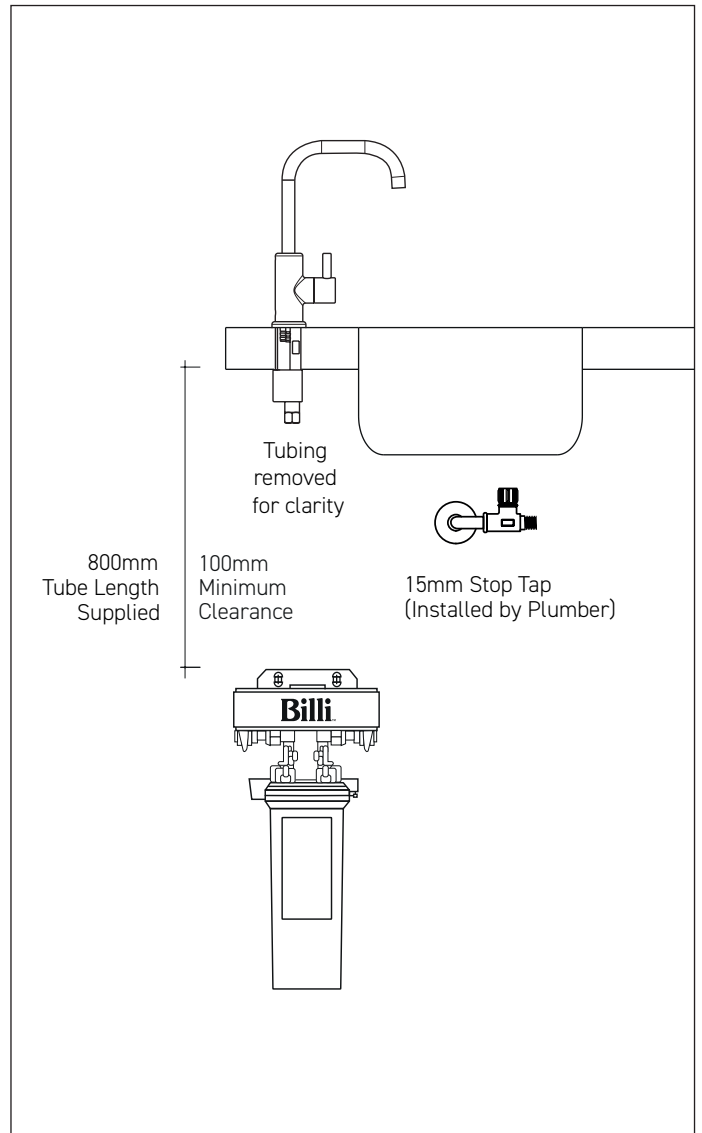

### WATER SUPPLY

A single 1/2" BSP (15mm) stop-tap with a male thread should be installed in an easily accessible position. Water supply must be microbiologically safe to drink, with a minimum dynamic water pressure of 250kPa and a maximum of 1000kPa.

### FILTRATION

Billi's range of premium filters utilise BWT's unique Fibron X technology. Billi's filter range provides superior taste, water quality, consistent filter life and peace of mind when it comes to hygiene.

Filter supplied: 994052 (0.2 micron). Replacement filters available: 994051 (5 micron option), 994054 (HSD option), 994055 (XPHSD

Fibron XP), 994056 (Sediment only) and 994060 (Micron HF Sediment Only).

### CERTIFICATIONS

Every Billi drinking water appliance is manufactured under a certified quality control system. All Billi commercial range models have been tested and comply with all required standards including: Watermark: WM-021882; Certified to AS/NZ3498 and AS/NZ 4020; ISO9001:2015, QEC 11627; WELL Cornerstone Member.

### WARRANTY

The Billi B1000 Range is covered by a comprehensive 2 year warranty on all parts and labour.

# Billi™

Billi Australia Pty Ltd  
42 Lucknow Crescent,  
Thomastown, Victoria  
3074 Australia

P 1800 812 321  
F +61 3 9469 0499  
W www.billi.com.au

visit us at



Designed and manufactured in to the highest quality standards