

CAROMA URBANE II- WALL SENSOR OUTLET (BASIN)

WATER EFFICIENT TAPWARE

INSTALLATION INSTRUCTIONS

Important Information

- * Trim kit (3-28) and body kit (1-2) are supplied separately.
- * Not suitable for gravity feed systems.
- * Outlet is fitted with a 4.5L/min. regulated aerator insert. This low flow rate may not be suitable for connection to some Instantaneous Gas Water Heaters, some Tempering Valves, some Solar Water Heaters & some Thermostatic Mixing Valves. Check with the manufacturers of these products.
- * Isolating stop taps(Not supplied) must be fitted to the hot & cold water supply connections. (Part No. 842018C Mini cistern 1/4T).
- * All pipework must be thoroughly flushed prior to installation, as foreign materials may block the solenoid or flow regulating device and reduce the flow of water.
- * The Solenoid control box can be Mains powered, Battery powered or Battery back-up.
- * The sensor cable items (12) & (13) in the trim kit are 1.5m long.

Installation

Roughing kit:

- 1) Fit the housing (1) onto a noggin in the wall and secure using 4 screws (not supplied) through the holes, **Fig. 1**. Before tightening, horizontal alignment must be checked by using the flat face on the top of the housing (1).

Important:-

- * The front face of the mounting plate or noggin must be parallel to the finished wall/tile face.
- * To avoid damaging the elbow (1b) , do not remove the protective sleeve (2) until installing the trim kit.
- * The rotational alignment of the housing (1) must be accurate.
- * The in-wall connection from elbow (1b) to threaded nipple (29) are not supplied.
- * Connection point (1a) is provided for terminating standard 25mm electrical conduit upto the control box (15) mounted in front of the wall.
- * The allowable in-wall range from finished wall/tile face to the noggin is 50 - 60mm, **Fig. 6**.
- * The wall/tile cut-out must be $\Phi 44 \times 94$ mm to ensure enough sealing surface for cover plate (4), **Fig. 4 & 6**.

Trim kit:

- 2) Check that the tiling flange on the housing (1) is flush with the finished wall/tile face. **Fig. 6**
 - i) Remove protective sleeve (2) from G1/2 thread of elbow (1b).
 - ii) Slide the cover plate (4) over the the exposed thread of elbow (1b) and check if it is the correct length, as shown. Cut to length if required, ensuring end face is square. Apply thread tape to the thread.
Important : Care must be taken that thread tape cannot become dislodged and block the flow regulating device, causing a reduction in water flow. To ensure correct installation, length of exposed thread must not exceed 8mm.
 - iii) Insert black sensor cable end (13) and red sensor cable end (12) into housing (1) and pass them through the hole of connection point (1a) as shown in (**Fig. 6**). Continue feeding the cables through the conduits (not supplied) until both red & black cable ends come out the other end in front of the wall.
 - iv) Ensure foam seal (3) is fitted on wall cover plate (4), slide the cover plate (4) over the thread of elbow (1b). Screw the adaptor (5) with two 'O' rings fitted onto threaded nipple using a 10mm allen key (6), untill the cover plate (4) is held securely against the wall/tile face. DO NOT OVERTIGHTEN.

- v) Apply suitable lubricant to the 'O' rings on adaptor (5). Carefully slide the outlet (7) onto the spigot of adaptor (5) until the back of the outlet abuts the cover plate (4) and top face of the outlet (7) is horizontal then tighten grub screws (8) using allen key (9).
Determine a suitable location for installation of control box (15) near the in-wall conduit exit point before proceeding with control box mounting.
Important: Do not pull the sensor cables forcefully, as it can damage the sensor cables or sensor connection.

3a) Solenoid Control box installation (Fixed mounting), Fig. 2: For installation onto solid walls; (brick, concrete etc.)

- i) Drill two $\Phi 6$ mm holes, 40mm deep and 104mm apart horizontally as shown in **Fig. 2**.
- ii) Insert small end of wall plugs (25) into drilled holes and tap until flush with wall/tile face.
- iii) Align the slots on fixing plate (27) with the holes on the wall, pass the screws (24) through the slots and insert into the wall plugs (25). Then tighten the screws. DO NOT OVERTIGHTEN.

For installation onto timber stud/MDF board:

- i) Drill two holes at 104mm apart horizontally to suit the self tapping screws supplied as shown in **Fig. 2**.
- ii) Align the slots on fixing plate (27) with the holes on the wall, pass the screws (24) through the slots and into the holes in the timber stud, then tighten the screws. DO NOT OVERTIGHTEN.

3b) Solenoid Control box installation (Removable), Fig. 3 & 5:

Optional removable bracket (26) (supplied) allows the control box to be lifted off quickly for easy access to battery compartment and solenoid.

- i) Remove the screws (24) using a phillips head screw driver.
- ii) Remove the wider fixing plate (27) and put it aside.
- iii) Take the narrower fixing plate (26) out of the bag, fit it at the back of the control box (15) by aligning the holes on the fixing plate (26) with the holes at the back of the control box (15). The cut-outs on the fixing plate (26) should be towards the bottom, as shown in **Fig.3**.
- iii) Fit the screws (24) and tighten, DO NOT OVERTIGHTEN.

For installation onto solid walls; (brick, concrete etc.)

- i) Drill two $\Phi 6$ mm holes, 40mm deep horizontally as shown in **Fig. 5**.
- ii) Insert small end of wall plugs (25) into drilled holes and tap until flush with wall/tile face.
- iii) Insert screws (24) into wall plugs, screw them until the head is 6mm away from wall/tile face as shown in **Fig. 5**.
- iv) Mount the control box (15) onto the screws (24).

For installation onto timber stud/MDF board:

- i) Drill two holes at 52mm apart horizontally to suit the self tapping screws supplied as shown in **Fig. 5**.
- ii) Insert the self tapping screws into the holes in the stud, screw them until the head is 6mm away from wall/tile face as shown in **Fig. 5**.
- iv) Mount the control box (15) onto the screws (24).

Note: The isolation stop taps (31) & (33), tempering valve (36), connection hoses (34), (35) are not supplied.

4) Flexible Tail Connections:

i) Sensor activated 'Cold' water (Fig.6)-

Connect one connection end of the flexible hose (22) to the inlet connection of control box (15), then connect other end (23) of flexible hose (22) to the cold isolating stop tap (31). Connect one end of another hose (22) to the outlet connection end of control box (15), then connect other end of flexible hose (22) to the threaded nipple (29). Hand tighten both connecting nuts until seal contacts the sealing face of the connection ends, then tighten a further one turn to provide a watertight joint.

ii) Sensor activated 'Tempered' water bypass (Fig.4)-

Connect one end of flexible tail (35) to cold isolating stop tap (31), connect other end of flexible tail (35) to the cold inlet of tempering valve (36). Connect one end of flexible hose (34) to hot isolating stop tap (33), connect other end of flexible tail (34) to the hot inlet end of tempering valve (36). Connect mixed water flexible tail (32) to mixed outlet connection end of tempering valve (36) and other end to inlet connector of control box (15).

Important: Flexible tails must not be kinked, twisted or in tension when installed. (Minimum Bend Radius:- 50mm). Do not install flexible tails where subject to ultra violet light.

- 5) **Sensor cable connections:** While aligning the 'D' profile of male and female connectors, connect red cable male connector (12) to red cable female connector (18) of control box(15), connect black cable female connector (13) to black male connector (17) of control box (15), connect power supply cable connector(20) to the black female connector (19) of control box(15). Ensure all cable connectors are pushed in fully.

- 6) Plug in power supply (21) to standard power outlet, turn on.
- 7) Turn on Hot and Cold stop taps. Check the connection ends to ensure there is no leakage. Tighten further if required.
- 8) Bring your hands under the spout to activate the waterflow, when hands are moved away, the water flow will turn off automatically.

Adding/Replacing batteries

- 1) Remove screws (16) using a phillips head screw driver then put the screws aside, Insert a flat blade screw driver in to the cover slot and pry it out to remove the cover.
- 2) Insert/replace 4 x 1.5V AA batteries following the "-" & "+" markings.
- 3) Fit the cover back on ensuring the seal is in place and compressed.

Replacing Aerator Insert

- 1) Aerator insert (10) can be removed with the key (11) provided.
- 2) Deposits of lime can be removed by washing in a vinegar solution.
- 3) When replacing aerator insert (10), be careful that thread is engaged correctly and 'O'-ring is not damaged as it enters the bore. Tighten securely (to prevent removal by hand) using key (11).

IMPORTANT

Pressure & Temperature Requirements.

- Hot and cold water inlet pressures should be equal.
- Static inlet pressure range : 150-800 kPa
New Regulation:- 500 kPa maximum static pressure at any outlet within a building. (Ref. AS/NZS 3500.1)
- Maximum hot water temperature : 80°C.

Installation Requirements.

- The installing plumber is responsible for waterproofing all penetrations for Taps in Shower areas at installation by a proprietary flange system or a sealant.(Ref AS3740)

WATER EFFICIENT TAPWARE

INSTALLATION INSTRUCTIONS

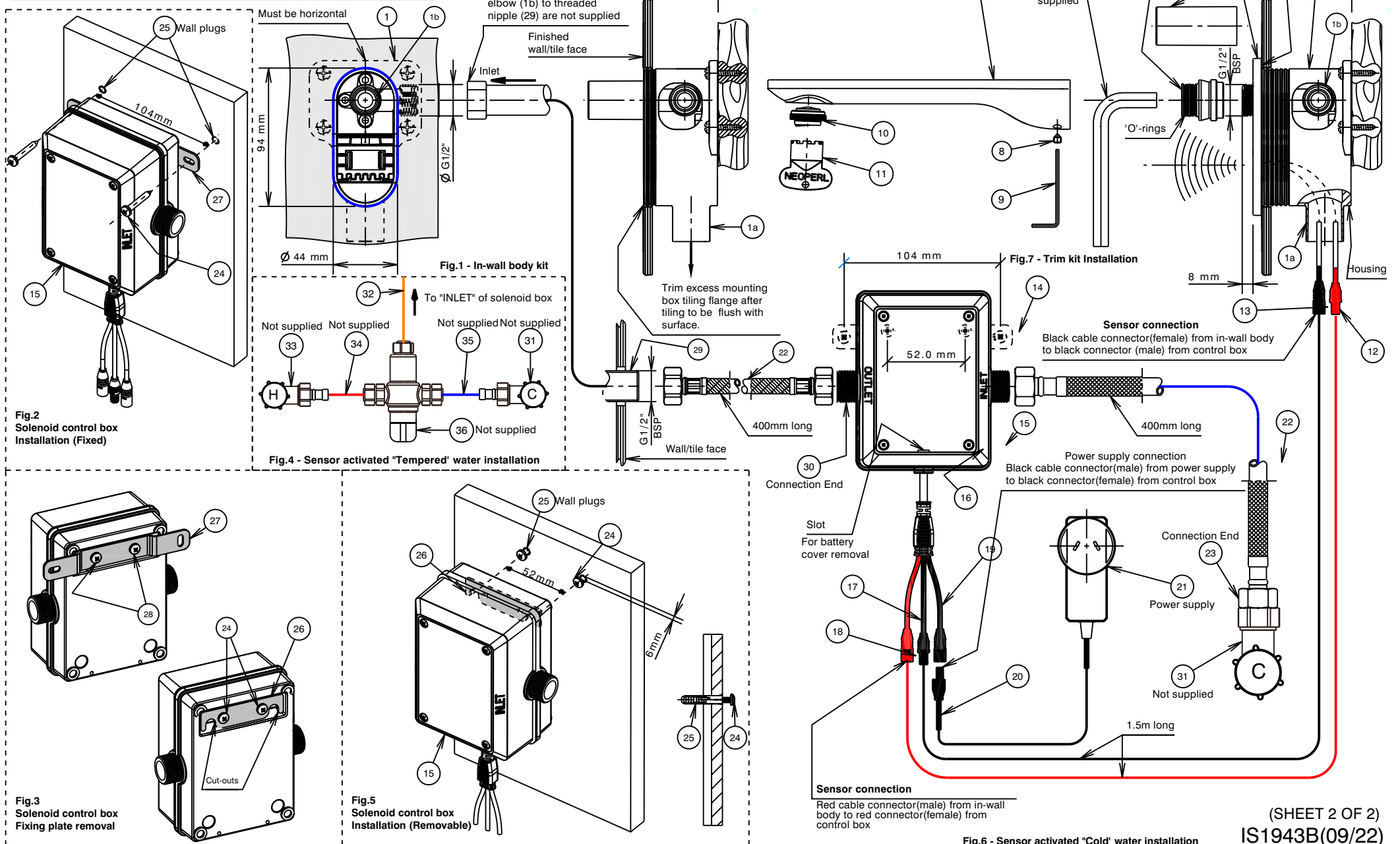

Fig.2 Solenoid control box Installation (Fixed)

Fig.4 - Sensor activated "Tempered" water installation

Fig.3 Solenoid control box Fixing plate removal

Fig.5 Solenoid control box Installation (Removable)

Sensor connection
Red cable connector(male) from in-wall body to red connector(female) from control box

Fig.6 - Sensor activated "Cold" water installation