

INSTALLATION INSTRUCTIONS

Important Information

- * Trim kit (2-34) and body kit (1) are supplied separately.
- * Both water based & non-water based soap solutions can be used. Soap solution viscosity should be within 100 to 2500 cps. For high viscosity soap solutions the foam level knob (33) must be set to minimum at '-' no air to enable smooth dispensing. For water based solutions, the foam level knob (33) must be turned anti-clockwise towards '+' max. air. (See Fig. 10)
- * Soap control unit must be primed before first use and after every refill. Follow priming instructions, as shown in Fig.10.
- * The soap control unit (12) is mains powered only. Separate battery box (20) is supplied which can be used as a battery backup.
- * The soap tube (8), air tube (9) and sensor cable item (14) in the trim kit are 1.5m long.

Installation

Roughing kit:

- 1) Fit the housing (1a) onto a noggin in the wall and secure using 4 screws (not supplied) through the holes, Fig. 1. Before tightening, horizontal alignment must be checked by using the flat face on the top of the housing (1a).
- Important:-**
- * The front face of the mounting plate or noggin must be parallel to the finished wall/tile face.
 - * To avoid damaging the mounting body(1b) , do not remove the protective cover(1c) until installing the trim kit.
 - * The rotational alignment of the housing (1a) must be accurate.
 - * Connection point (1d) is provided for terminating standard 25mm electrical conduit upto the control unit (12) mounted in front of the wall.
 - * The allowable in-wall range from finished wall/tile face to the noggin is 50 - 60mm, Fig. 3.
 - * The wall/tile cut-out must be $\Phi 44 \times 94$ mm to ensure enough sealing surface for cover plate (10), Fig. 1.

Trim kit:

- 2) Check that the tiling flange on the housing (1a) is flush with the finished wall/tile face. Fig. 3. Cut if required.
 - i) Remove protective cover (1c) from mounting body (1b).
 - ii) Check that the front face of the mounting body(1b) is at least 5mm from the front of finished wall/tile face. 5mm spacer (4) & 10mm spacer (3) are provided to bring the outlet forwards if required. Spacers (3)or (4) can be placed between item (2b) and body (1b), as shown in Fig. 2.
 - iii) Insert the soap & air tubes (8) & (9) into the housing (1a) and pass them through the hole of connection point (1d) as shown in (Fig. 2). Wire draw/fish tape can be used by carefully tying it to the tubes and pass through the conduits (not supplied) until the tubes come out at the open end, Do not pull the soap tubes out forcefully. Place the mixing valve (7) inside the housing as shown in (Fig. 2 & 3).
 - iv) Fit the spring washers (6) onto the 3 screws (5).
 - v) Align the 3 holes on the flange (2b) of outlet (2a) with the holes on mounting body (1b), insert screw (5) along with washer (6) into the flange (2b), through the threaded hole in body (1b) then fit the remaining 2 screws in remaining 2 holes in similar manner, screw them in and tighten using 3mm allen key.

- vi) Apply a suitable clear sealant to the back edge of the cover plate (10), leaving an unsealed section at the bottom for drainage. Insert black sensor cable (11) from the cover plate (10) into housing(1a) and pass it through the hole of connection point (1d) as shown in (Fig. 3). Continue feeding the cable through the conduits(not supplied) until the black cable end comes out the open end in front of the wall. Pass the hole in the cover plate (10) along with seal (10a) over the outlet as shown in (Fig.3), slide it back, position the cover plate by keeping the sides vertical and press firmly to ensure proper seal.

Note: Wire draw/ fish tape can be used by carefully tying it to the cable end and pass through the conduits(not supplied) until the cable comes out at the open end in front of the wall. Determine a suitable location for installation of control unit(12) near the in-wall conduit exit point before proceeding with control unit mounting.

Important: Do not pull the sensor cables forcefully, as it can damage the sensor cables or sensor connection.

3) Connections :

a) Soap tube and air tube connections, (Fig. 7 & Fig. 11):

Identify the embossings "SOAP" & "AIR" under the soap unit (12). Press clip (13), slide the clip down the tube labelled "SOAP". Fit soap tube (8) onto the boss next to embossing "SOAP" Slide the clip up over the tube (8) and ensure clip (13) is fitted onto groove of the boss to prevent soap tube from being removed. In the same way, fit air tube labelled as "AIR" (9) onto the boss next to embossing "AIR".

b) Sensor cable connection, (Fig.7):

By aligning the profile of connectors (14) & (15), connect the sensor cable (14) from cover plate (10) to the end of sensor cable (15) of soap control unit as shown in Fig. 7.

c) Power cable connection:

While aligning the 'D' profile of male and female connectors Connect male connector of power cable (16) to female connector (17) of soap control unit (12) as shown in Fig. 7. Connect male connector (18) to female connector (19) of battery box (20). Ensure all cable connectors are pushed in fully.

4a) Soap Control unit installation (Fixed Mounting):

For installation into solid walls; (brick, concrete etc.)

- i) Drill two $\Phi 6$ mm holes, 40mm deep and 104mm apart horizontally as shown in Fig. 4.
- ii) Insert small end of wall plugs (22) into drilled holes and tap until flush with wall/tile face.
- iii) Align the slots on fixing plate (23) with the holes on the wall, pass the screws (24) through the slots and insert into the wall plugs (22). Then tighten the screws. DO NOT OVERTIGHTEN.

For installation into timber stud/MDF boards:

- i) Drill two holes at 104mm apart horizontally to suit the self tapping screws supplied as shown in Fig. 4.
- ii) Align the slots on fixing plate (23) with the holes on the wall, pass the screws (24) through the slots and insert into the wall plugs (22). Then tighten the screws. DO NOT OVERTIGHTEN.

4b) Soap control unit installation (Removable):

Optional removable bracket (supplied) allows the control unit to be lifted off quickly for easy access to pump functions and bottle re-fill.

- i) Remove the screws (25) using a phillips head screw driver.
- ii) Remove the wider fixing plate (23) and put it aside.
- iii) Take the narrower fixing plate (26) out of the bag, fit it at the back of the control unit (12) by aligning the holes on the fixing plate (26) with the holes at the back of the control unit(12). The cut-outs on the plate should be towards the bottom, as shown in Fig.6.
- iv) Fit the screws (25) and tighten, DO NOT OVERTIGHTEN.

For installation into solid walls; (brick, concrete etc.)

- i) Drill two $\Phi 6$ mm holes, 52mm apart and 40mm deep horizontally as shown in Fig. 6.
 - ii) Insert small end of wall plugs (22) into drilled holes and tap until flush with wall/tile face.
 - iii) Insert screws (24) into wall plugs, screw them until the head is 6mm away from wall/tile face as shown in Fig. 6.
 - iv) Mount the control unit (12) onto the screws (24).
- For installation into timber stud or MDF boards:**
- i) Drill two holes at 52mm apart horizontally to suit the self tapping screws supplied as shown in Fig. 6.
 - ii) Insert screws (24) into the holes and screw them until the head is 6mm away from wall/tile face as shown in Fig. 6.
 - iii) Mount the control unit (12) onto the screws (24).

5) Soap Bottle Installation (See Fig. 9)

Pass the soap bottle (27) over the tube (28) coming out of the soap control unit (12), screw the bottle under the unit and tighten. Determine a suitable location for installation of battery box (20) near the soap control unit before proceeding with battery box mounting.

6) Battery box installation :

For installation into solid walls; (brick, concrete etc.)

- i) Drill two $\Phi 6$ mm holes, 40mm deep and 22mm apart vertically as shown in Fig. 8.
 - ii) Insert small end of wall plugs (29) into drilled holes and tap until flush with wall/tile face.
 - iii) Align the slots on bracket (30) with the holes on the wall, pass the screws (31) through the slots and insert into the wall plugs (29). Then tighten the screws DO NOT OVERTIGHTEN.
 - iv) Slide the battery box (20) onto shoulder of bracket (30).
- For installation into timber stud or MDF boards:**
- i) Drill two holes at 22mm apart vertically to suit the self tapping screws supplied as shown in Fig. 8.
 - ii) Align the slots on bracket (30) with the holes on the wall, pass the screws (31) through the slots and insert into the timber stud. Then tighten the screws (31). DO NOT OVERTIGHTEN.
 - iii) Slide the battery box (20) onto the shoulders of bracket (30). Plug the power supply (21) into the mains and turn it ON.

7) Adding/Replacing batteries (See Fig. 8)

- 1) Remove screws (32) using a phillips head screw driver then put the screws aside, remove the cover of battery box.
- 2) The flat head screwdriver can be used in the battery box to prise the cover open.
- 3) Insert/replace 4 x 1.5V 'D' batteries following the "-" & "+" markings.
- 4) Fit the cover back on ensuring the seal is in place and compressed.

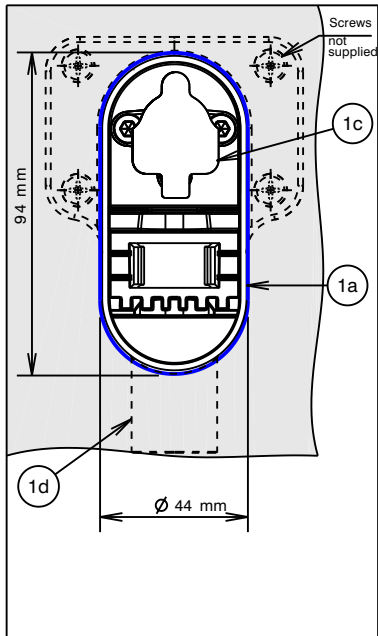

Fig.1 - Roughing kit installation

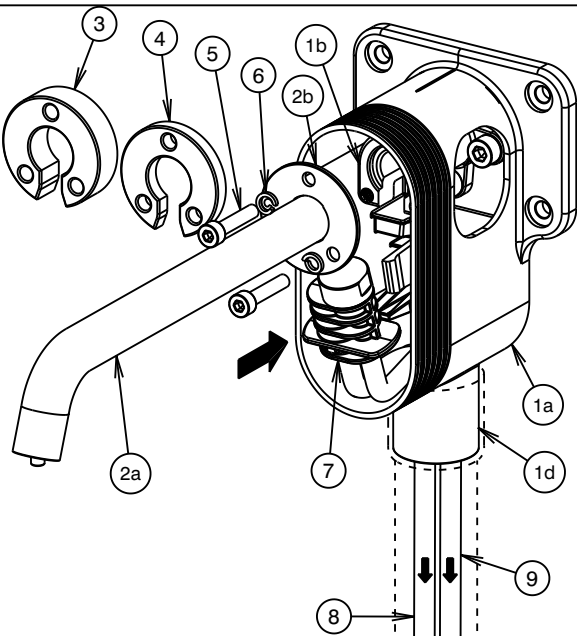

Fig.2 - Outlet & mixing valve installation

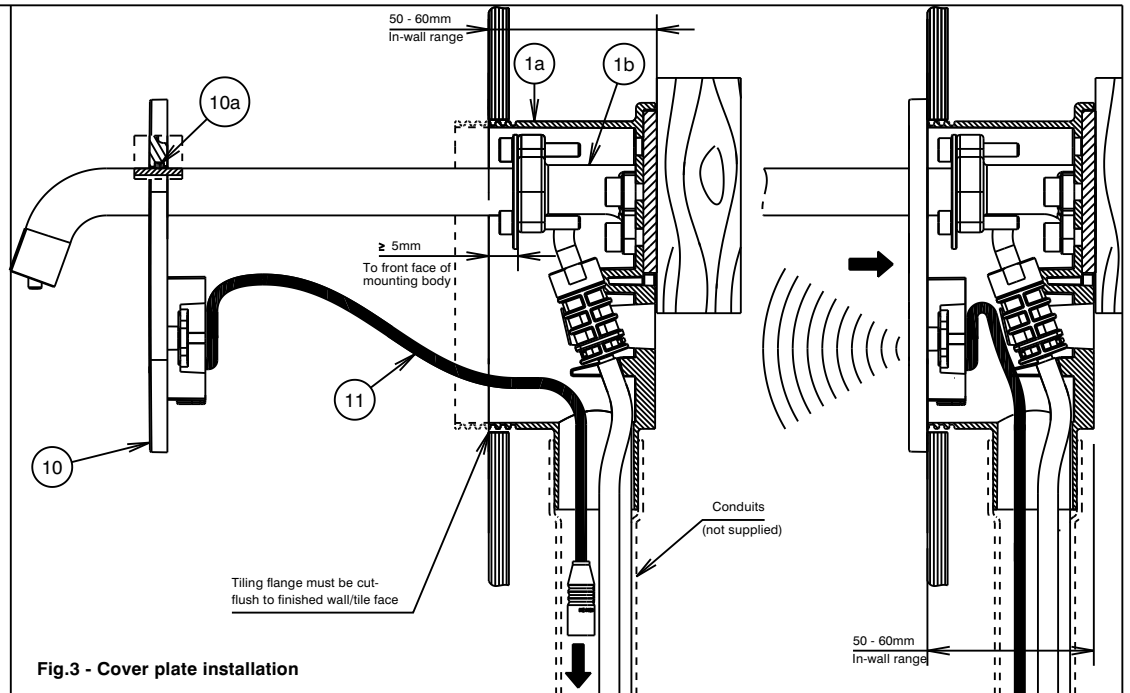

Fig.3 - Cover plate installation

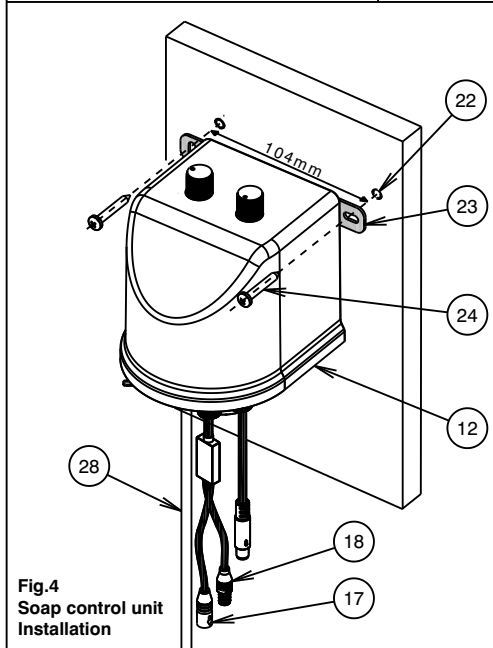

Fig.4
Soap control unit
Installation

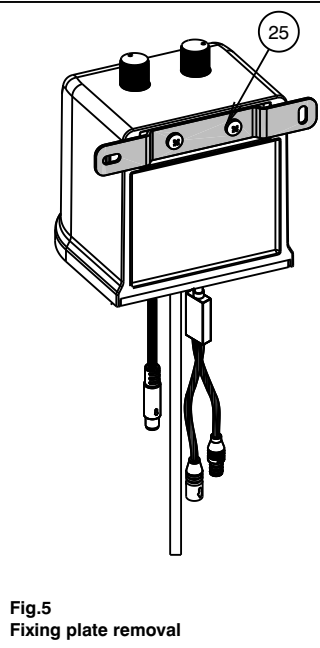

Fig.5
Fixing plate removal

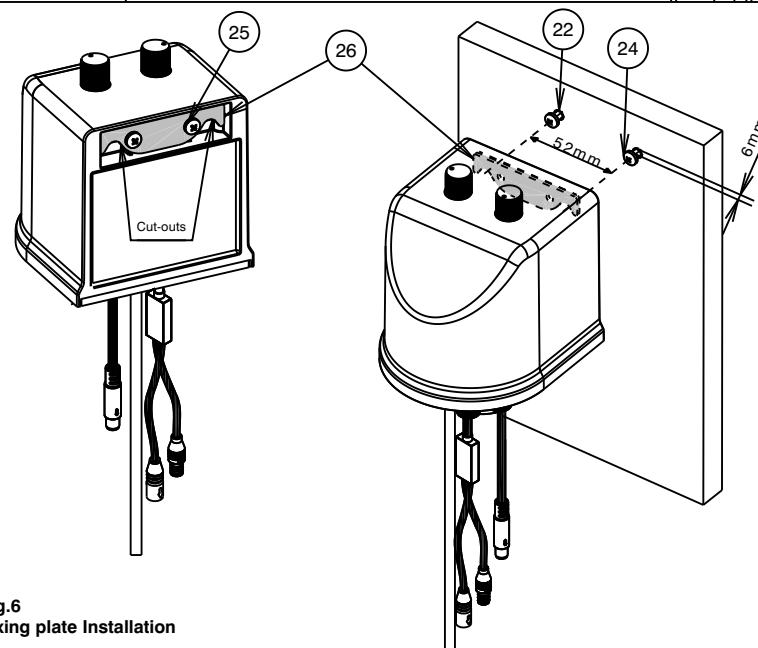

Fig.6
Fixing plate Installation

