

You are backed by the ARES Tool Performance Assurance!

ARES TOOL warrants this product to be free from defects in materials and workmanship under normal use and service. A defective product may be returned for a free replacement within 90 days from the date of purchase, provide that product is returned immediately after discovery of defect. This warranty shall be valid only when proof of purchase (receipt) showing the date of purchase accompanies the defective product.

Exclusions:

These warranties exclude blades, bits, punches, dies, bulbs, fuses, batteries, and other consumables which must be replaced under normal use and service. These warranties shall not apply to any product or part which is used for a purpose for which it is not designed, or which has been repaired or altered in any way so as to affect adversely its performance or reliability, nor shall these warranties apply to any product or part which is subject to misuse, neglect, accident, or wear/tear incident to normal use and service



3/8" DRIVE DAMAGED BOLT AND STUD EXTRACTOR TOOL

OPERATOR'S MANUAL

STORE THIS MANUAL IN A SAFE
PLACE FOR FUTURE REFERENCE

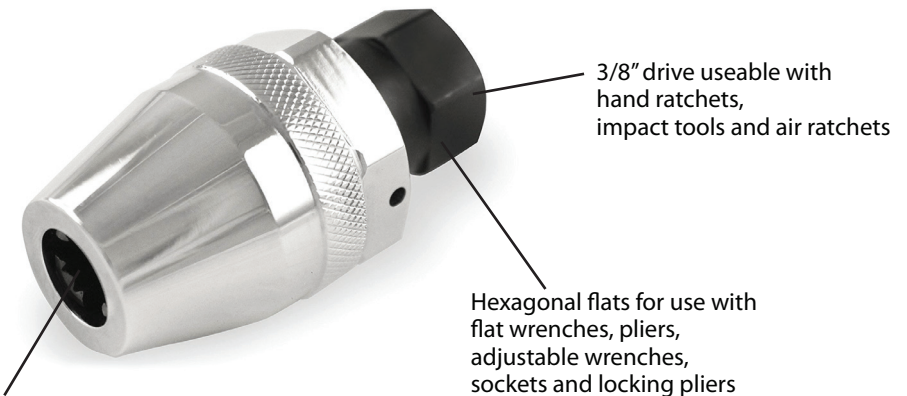

Universal Design allows
for removal of 1/4" to 1/2"
studs (6-12mm)

3/8" drive useable with
hand ratchets,
impact tools and air ratchets

Hexagonal flats for use with
flat wrenches, pliers,
adjustable wrenches,
sockets and locking pliers



NEED HELP?

(800) 340-1442

www.arestool.com

customerservice@arestool.com

Don't forget to register your product

OPERATION

1. Attach the extractor tool to your favorite 3/8 drive impact tool or have a set of pliers, a wrench or a ratchet/T-handle and socket handy and ready to use with the extractor.
2. Place the head of the extractor over the rounded, rusted, painted or broken off bolt or stud (1/4" to 1/2" or 6-12mm).
3. Using constant force and pressure (or let the tool do the work for you), break the damaged bolt or stud loose.

NOTES

1. The design of this extractor allows for equal and constant pressure over the center of the bolt or stud which gives you superior leverage and torque and makes the job that much easier.
2. Universal design allows for removal of 1/4" to 1/2" studs or bolts (6-12mm)
3. Compact design allows access into small areas, where studs may be hard to reach.
4. This tool can be used for a variety of applications including broken Exhaust Manifolds, oil filler plugs, rounded starter bolt and low grade bolts left in saltwater.
5. If the damaged bolt or stud is extremely difficult to break loose, consider using WD-40 or another type of penetrating lubricant or grease. Let the lubricant rest for a few minutes before attempting to break the damaged bolt or stud loose again with the extractor tool.

MAINTENANCE

1. Remove dust, moisture and other contaminants with a clean brush, or soft, lint free cloth.
2. Do not use any abrasive materials that could damage the tool.
3. When tool is not in use, store the tool in a clean dry area.

