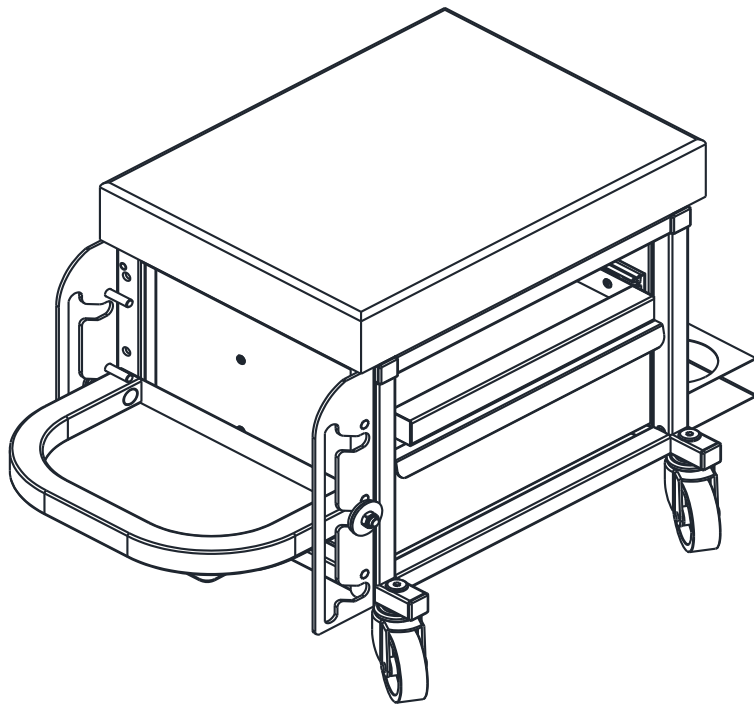

ARES

HEAVY-DUTY MULTIFUNCTION MECHANICS ROLLING SEAT

OPERATIONS MANUAL

**FEATURES****WARNING****ASSEMBLY****WARRANTY**

NEED HELP?

(206) 453-6776

www.arestool.com

customerservice@arestool.com

Don't forget to register your product!

WARNING

Please read all warnings carefully. Failure to follow these warnings could result in serious injury or death.

- Do not stand on seat.
- Sit on seat center to prevent accidental tipping or loss of balance.
- Use only on smooth level surfaces.
- Check for proper seat and caster installation before using.
- Use of this roller seat on any surface other than a hard, level surface will affect roller seat's stability and may result in personal injury.
- Do not place under automobile tires to move or reposition a vehicle.
- Do not exceed rated capacity – 350 lbs.
- Do not use if one or more wheels are inoperative.
- Do not use if any part of the support structure is broken, split or cracked.
- Periodically lubricate all moving parts.
- Check all nuts and bolts frequently to make sure they are secure and tight.
- Store the unit in a secure place in an upright position when not in use.
- Do not use as a toy or skateboard.
- Keep out of reach of children.
- To avoid suffocation, destroy any polybags. Do not allow children to play with polybags.

FEATURES

1. An ideal accessory for any garage, workshop, or auto detailing shop.
2. Durable steel construction with a 350 lbs. capacity.
3. Seat dimension:
L370 X W280 X H45 (mm)
14.57"L x 11.02"W x 1.77"H
4. Rugged steel construction with padded cushion seat for durable use and a comfortable seat.
5. Tool group can rotate angle.
6. There is a cup holder on the left.
7. There is a drawer and a tray.
8. Dimensions -
L525 X W370 X H375 (mm)
20.67"L x 14.57"W x 14.76"H
9. Four Ø2.5" swivel castors for easy maneuverability.
10. All square iron pipes:
20 X 20 (mm) 0.79 x 0.79"

ASSEMBLY

Attach the 4 casters to the main unit using the Hex Cap Nuts and washers as shown.

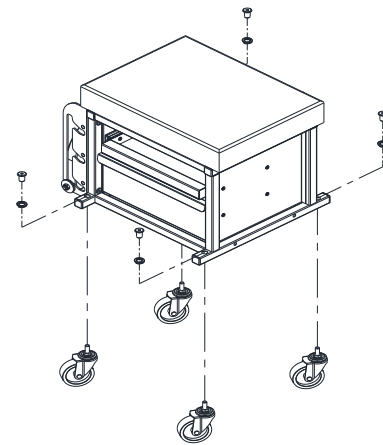

Attach the Can Holder to the main unit using the hardware provided as shown.

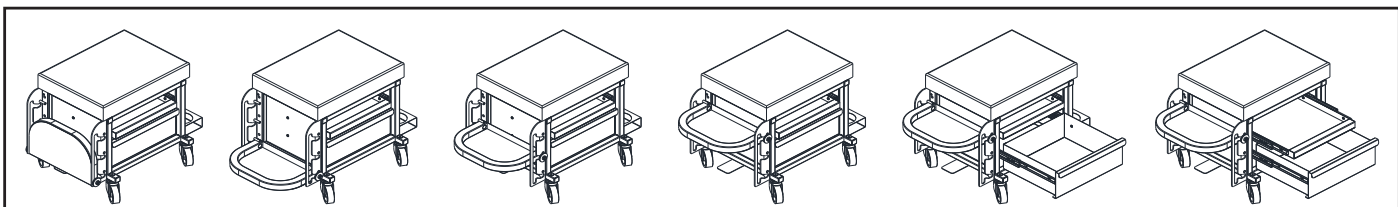
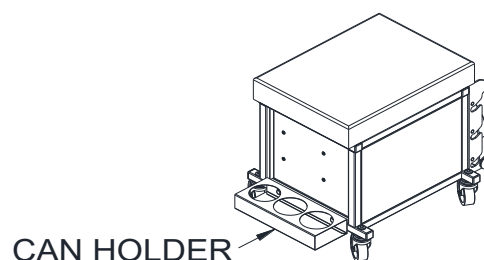
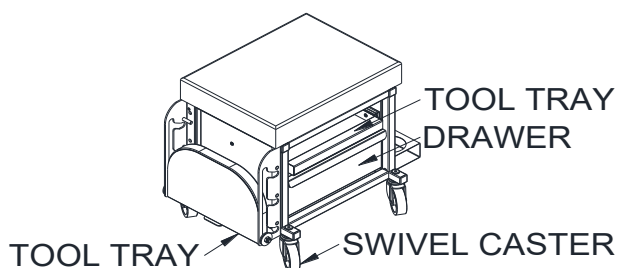
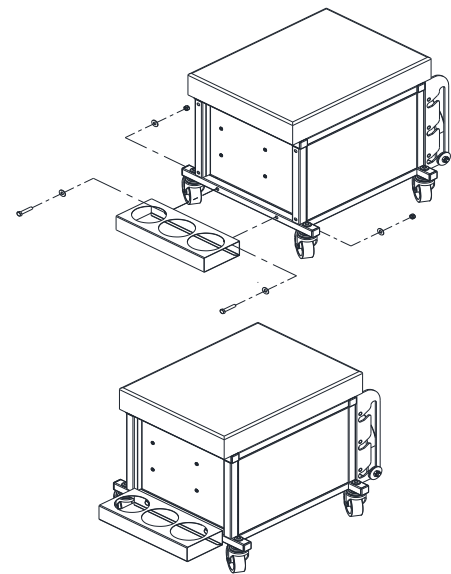

HEAVY-DUTY MULTIFUNCTION MECHANICS ROLLING SEAT

WARRANTY

You are backed by the ARES Tool Performance Assurance!

ARES TOOL warrants this product (excluding carrying cases and storage accessories and the product categories set forth below) to the original purchaser for its useful life (not to exceed one year for products with electrical or electronic components) against defects and deficiencies in material and workmanship.

This **LIMITED LIFETIME WARRANTY** does not cover products which in ARES Tool's judgement have been subject to negligence, misuse, abuse, accident, improper storage, alteration, improper repair, disassembly and/or reassembly. Normal wear and tear are also excluded. Deficient products will be replaced or repaired.

Please call or email at (206) 453-6776 / ares@arestool.com for more details or to receive support.

This warranty excludes blades, bits, bit sockets, carrying cases, pouches, torque products, punches, dies, bulbs, fuses, batteries, and other consumables which must be replaced under normal use and service. These warranties set forth herein are the sole warranties applicable to Products and is in lieu of all other warranties, whether expressed, implied or statutory.

The implied warranties of merchantability and fitness for a particular purpose are specifically excluded. Customer's sole and exclusive remedy for breach of this Warranty is, at the option of **ARES TOOL**, repair or replacement of the defective product.

Please visit us at WWW.ARESTOOL.COM to register your product and sign up for our ARES Tool Club

**B59 MADE IN TAIWAN
HECHO EN TAIWAN
FABRIQUÉ À TAIWAN**



WARNING:
Cancer and Reproductive Harm-
www.p65Warnings.ca.gov



**ALWAYS WEAR EYE
PROTECTION THAT COMPLIES
WITH ANSI STANDARD**



PLEASE RECYCLE



POR FAVOR RECICLE
VEUILLEZ RECYCLER