



www.Hsputelids.com

1300 441 498

Part No: DM18 & MBT18

Fitting Time: 45mins



**ISUZU D-max 07/20+ &
MAZDA BT50 09/20+**

HSP TAIL LOCK

FITTING INSTRUCTIONS

—GENERAL NOTES

- Read through the fitting instructions prior to installation of accessory.
- Ensure all recyclable components and packaging are discarded and recycled following local recycling regulations.
- Safely store and protect any removed vehicle components.

—SAFETY NOTES

- Check that all work practices comply with safety standards.
- Please wear appropriate clothing and use safety equipment.

—FITTING TIME



45mins

—PARTS SUPPLIED

Part Description	Part Number	Quality/ Length	CHECK LIST
TAIL LOCK ASSEMBLY			
Main Bracket	DM18-A	1	
ROD	DM18-B	1	
Actuator	ACT-01	1	
Wiring	CL-LOOM-LONG	1	
Patch Wiring	DM-PATCH	1	
FASTENERS			
Actuator Screws	36	2	
20mm M6 Bolt	16	1	
12mm M6 Bolt	1	1	
OTHER			
Cable Ties		5	
Fitting Instruction		1	

— Step 1 —

Fit rod into actuator as shown. Push Plastic striker on to the actuator till it clicks into position.

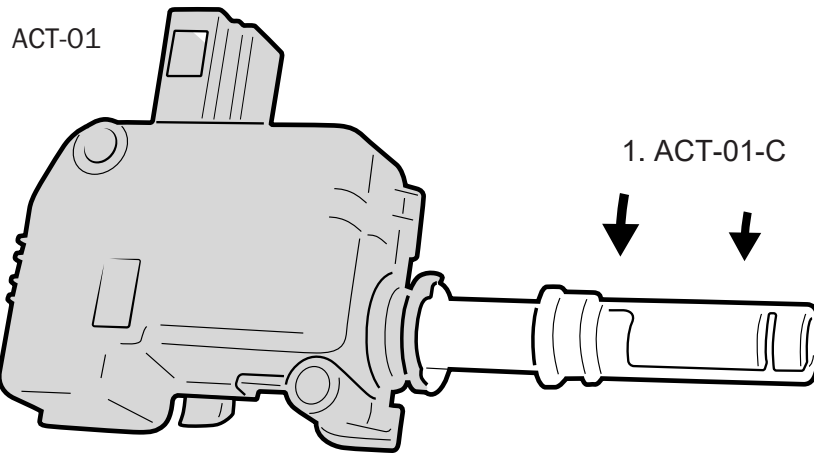

— Step 2 —

Fit the pin to the plastic striker (ACT-01-C).

A flathead screw driver may be used to lever the striker to allow for the pin to slide in.

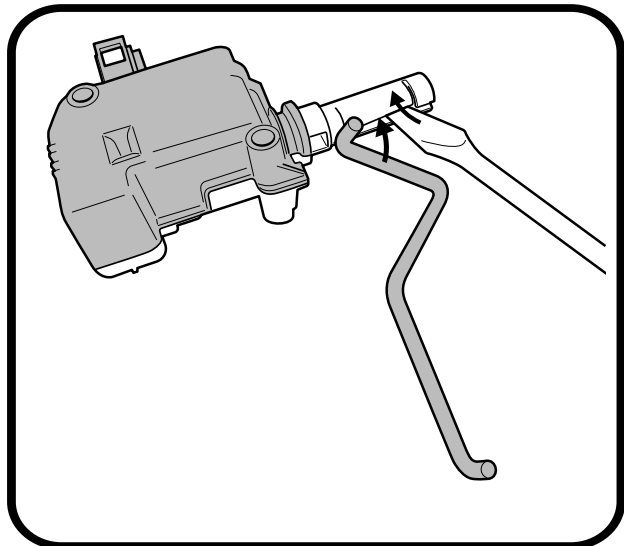
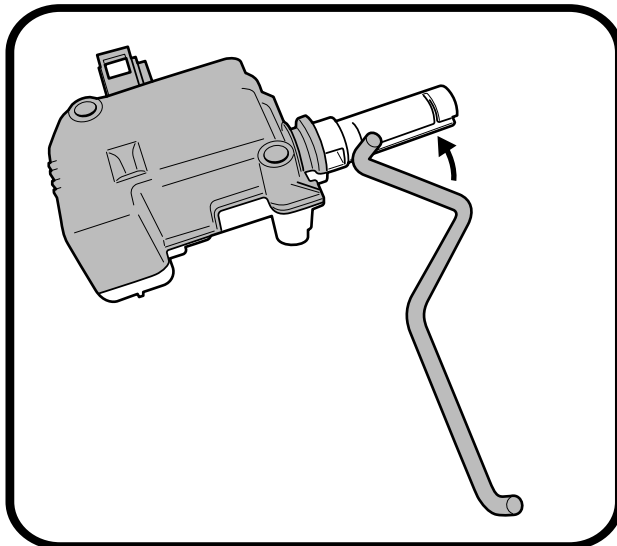

— Step 3 —

Assembled actuator

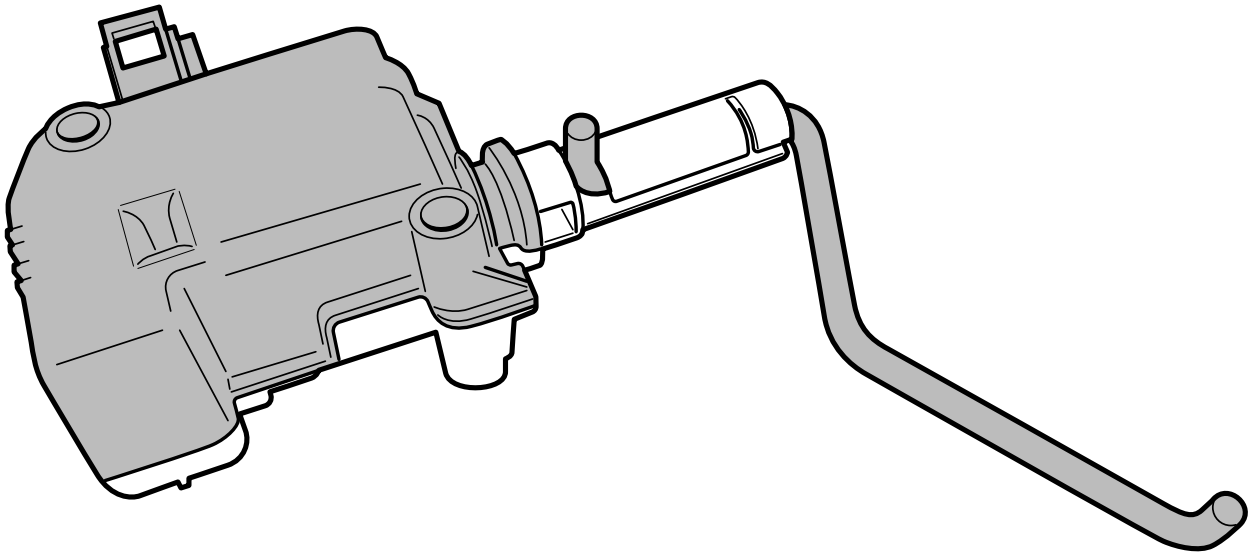

— Step 4 —

Line up the assembled actuator mounting holes with the main bracket mounting holes as shown.

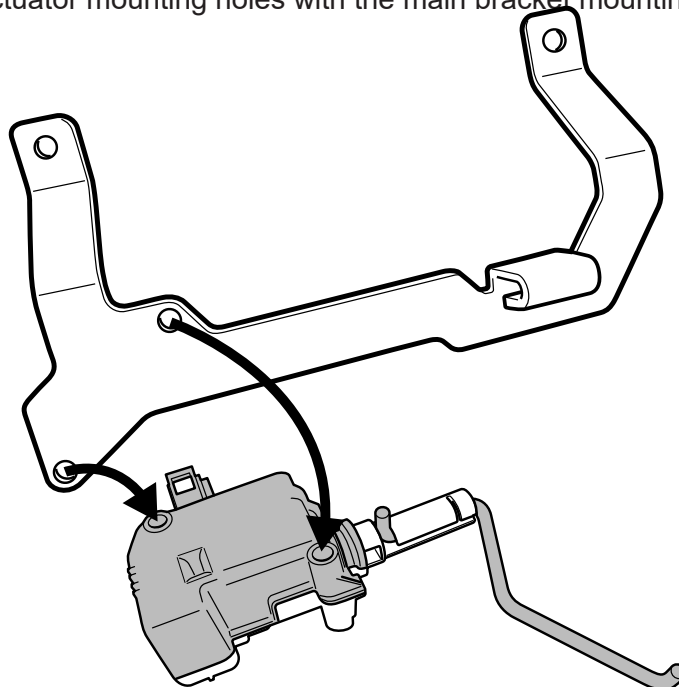

— Step 5 —

Fasten using the actuator screws.

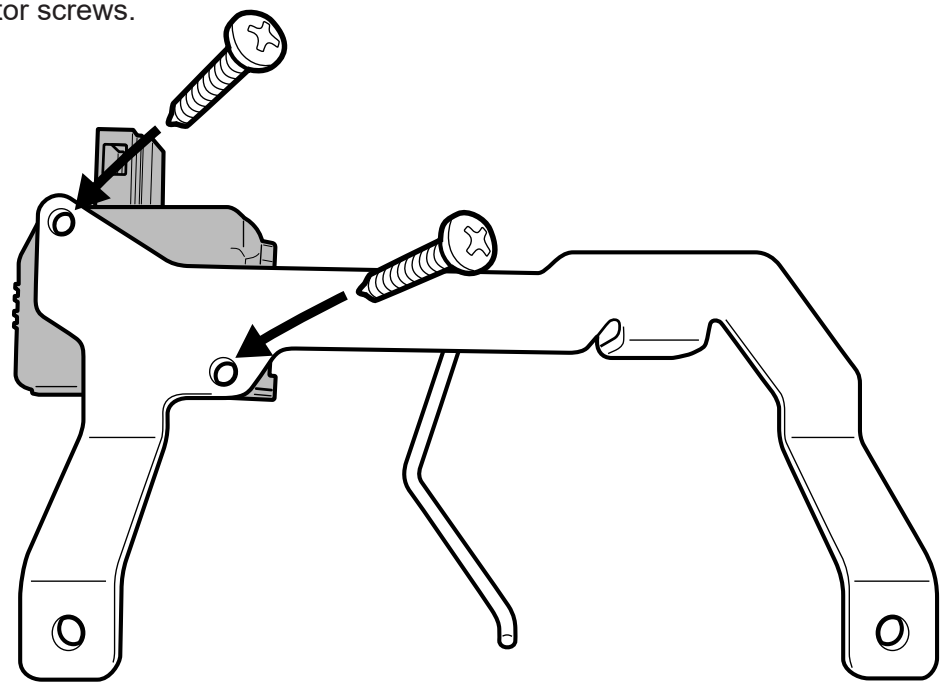

— Step 6 —

Assembled locking system.

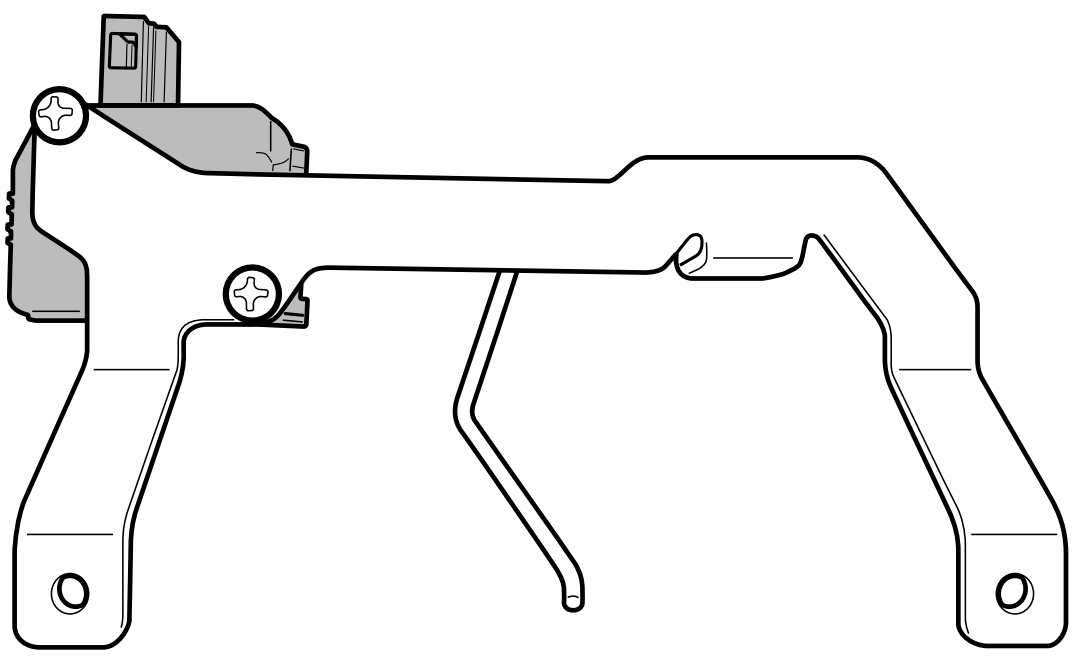

— Step 7 —

Remove tail gate cover.

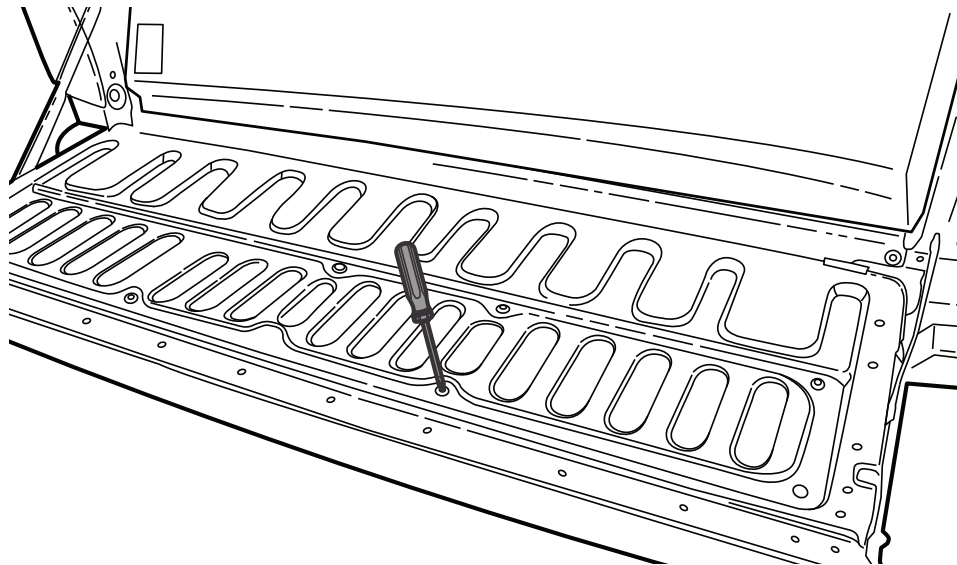

— Step 8 —

1. Disconnect the indicated rods.
2. Unfasten the indicated bolts and discard.

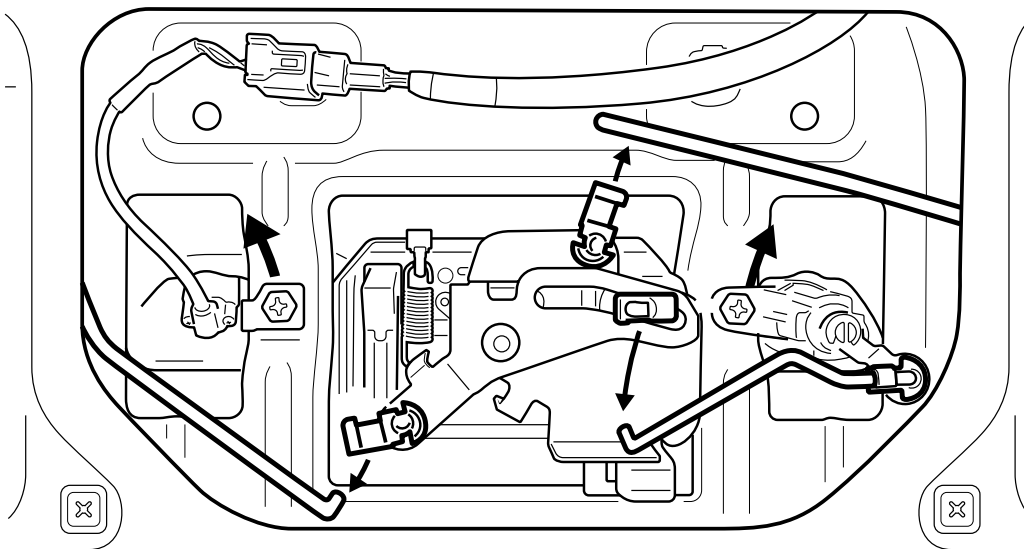

— Step 9 —

Disconnect the indicated rod from lock barrel and discard.

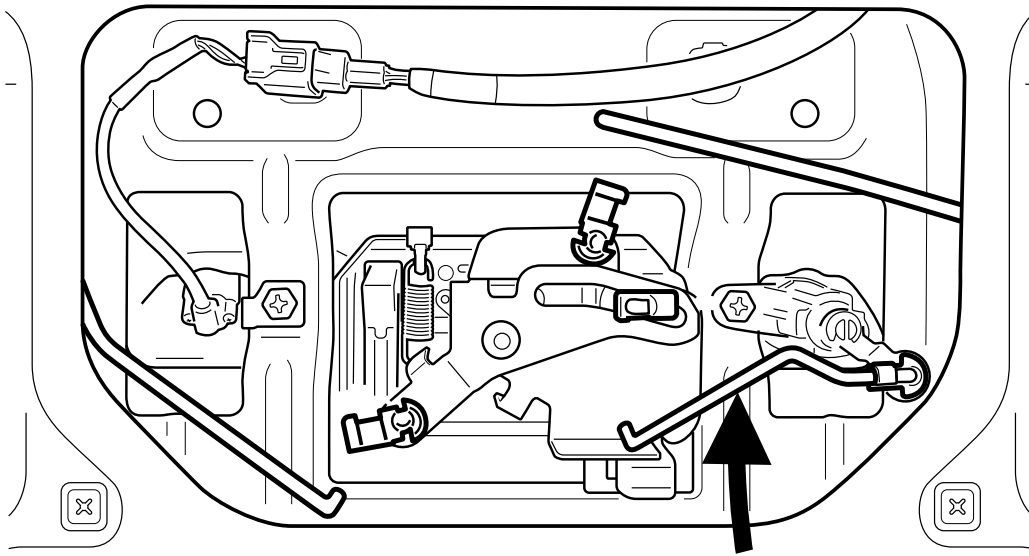

— Step 10 —

Connect long loom to the actuator

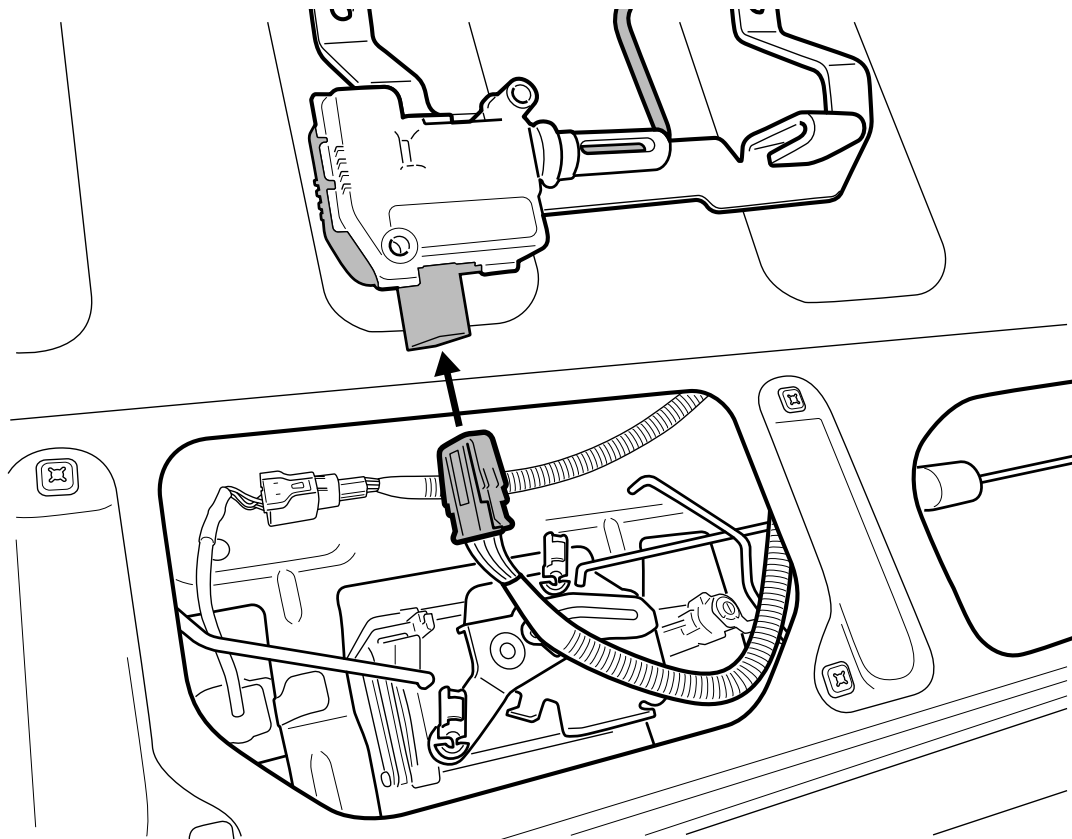

— Step 11 —

Insert and align bracket mounting holes with the factory mounting points.

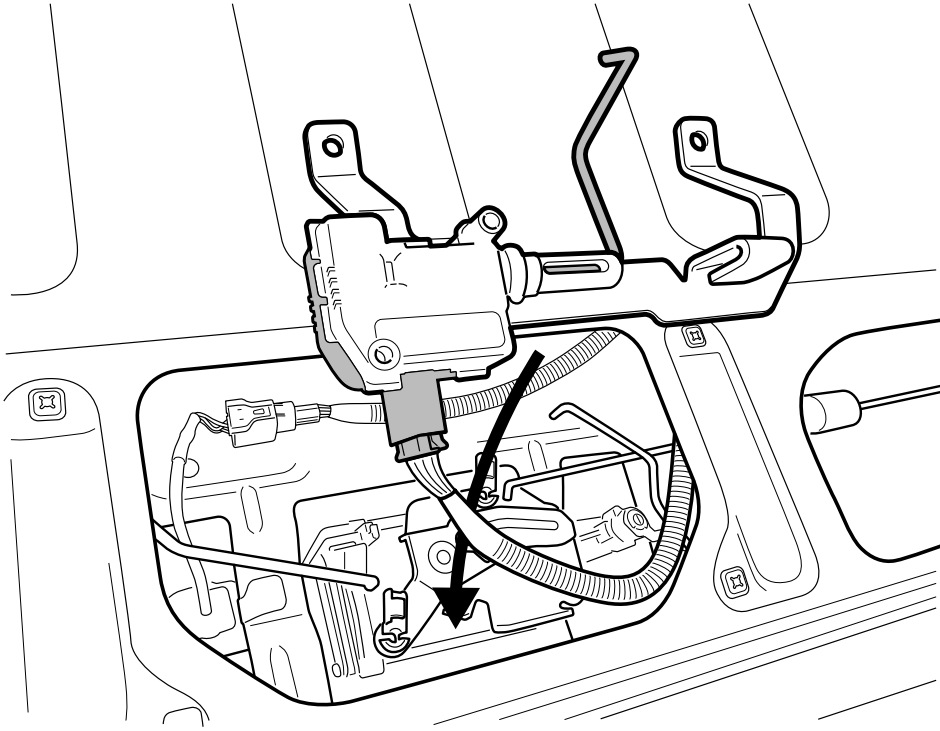

— Step 12 —

- 1) Use the included 12mm M6 Bolt to fasten
- 2) Use the included 20mm M6 Bolt to fasten.

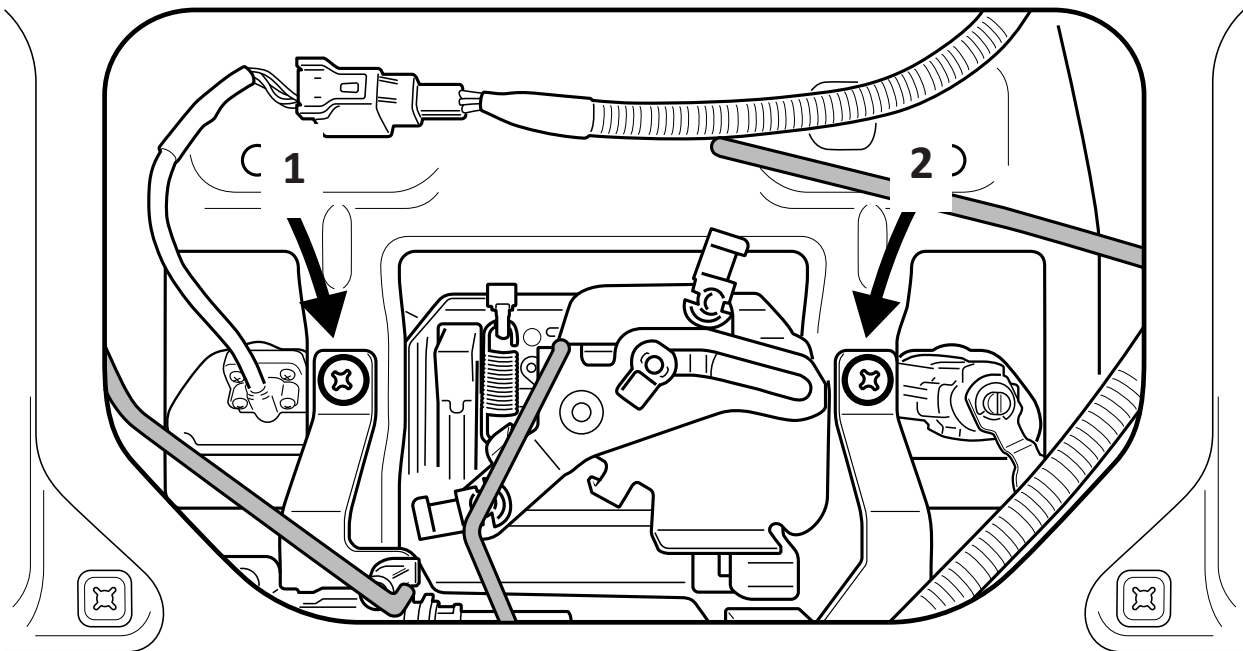

— Step 13 —

Connect the actuator rod to the indicated section.

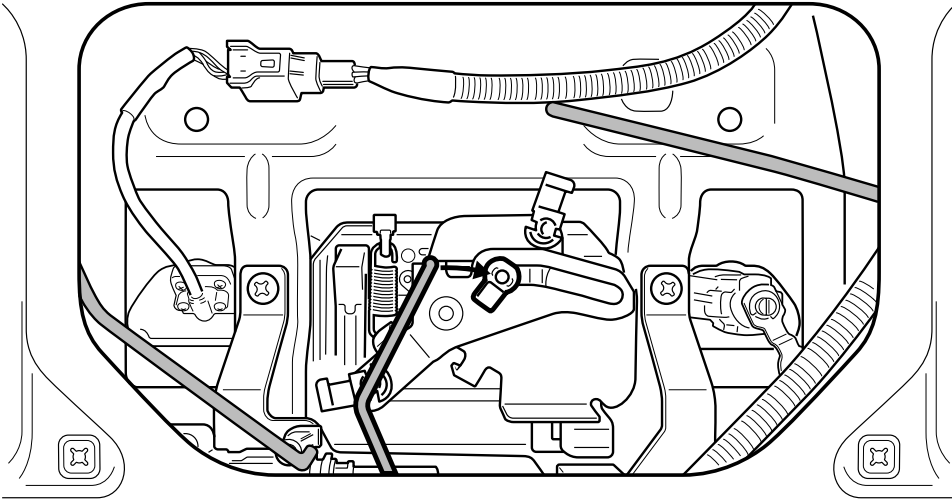

— Step 14 —

Reconnect the indicated rods.

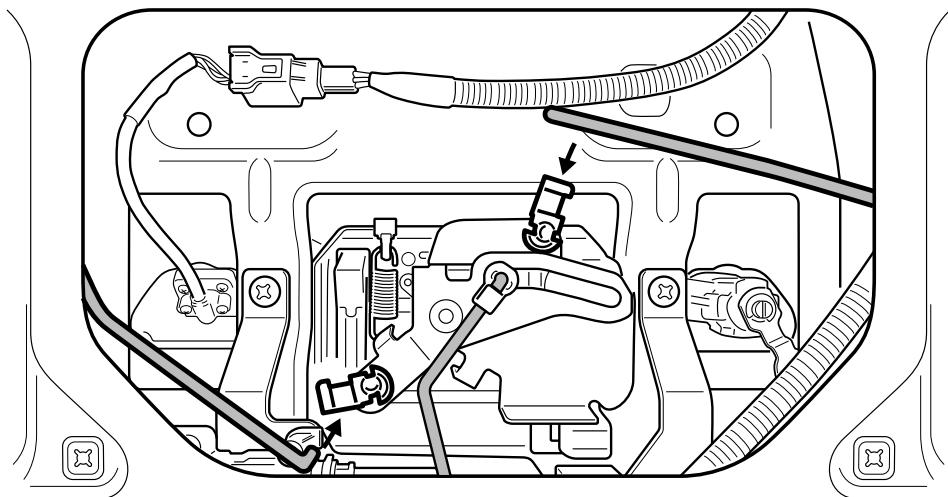

— Step 15 —

Check to see bolts are fastened and rods are connected.

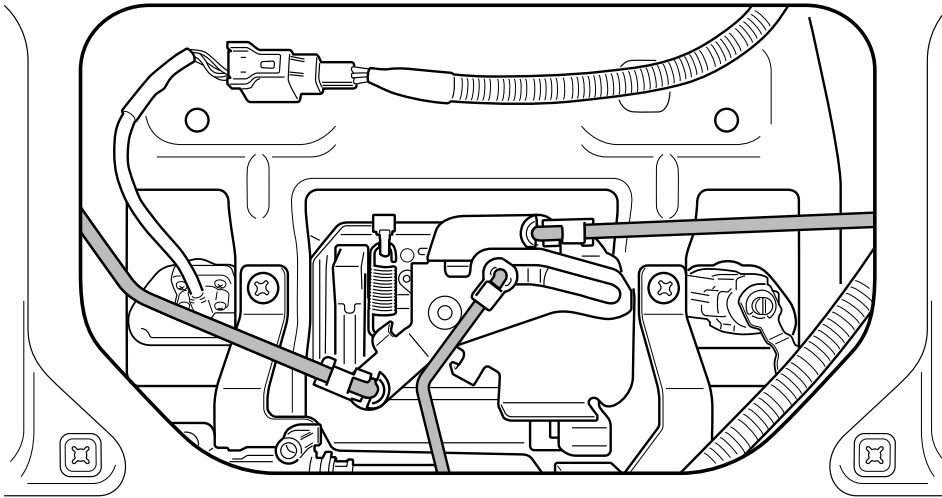

— Step 16 —

Run wiring from tailgate under the car

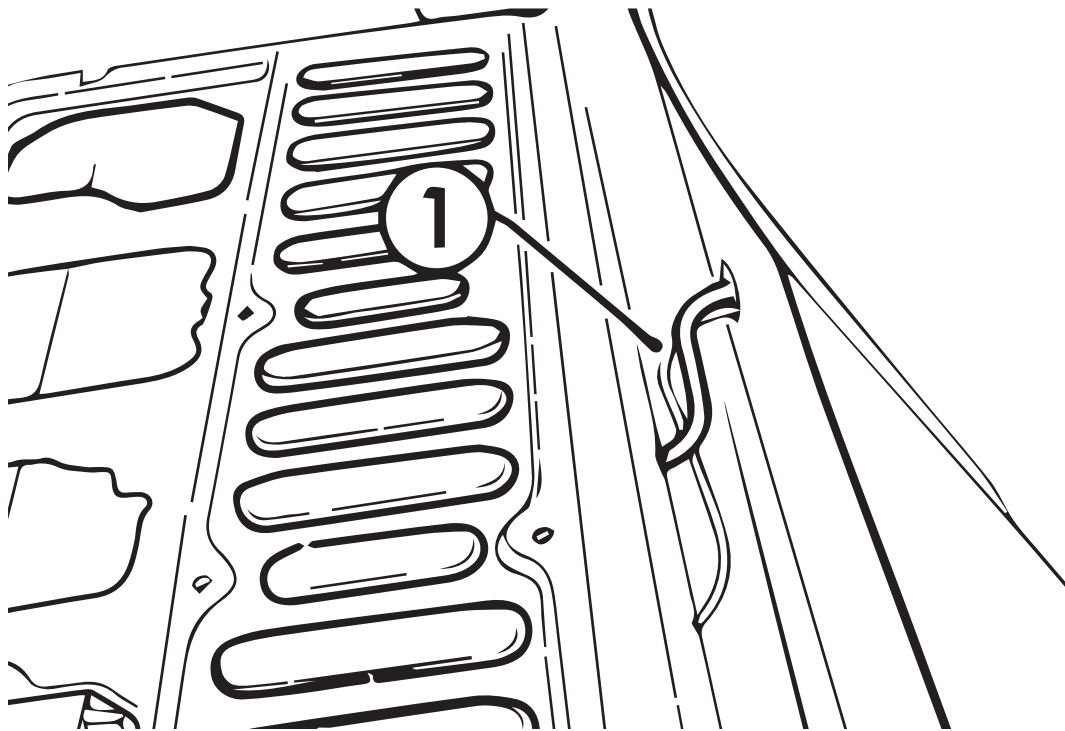

Step 17

Run wiring from tailgate to front drivers side kick panel. Find the large grommet on the firewall, make a small incision & run the loom through it to enter the cab and towards the kick panel (Allowing adequate length to reach the patch harness) . Seal accordingly.
Now cable tie wiring every 500mm over chassis rail.

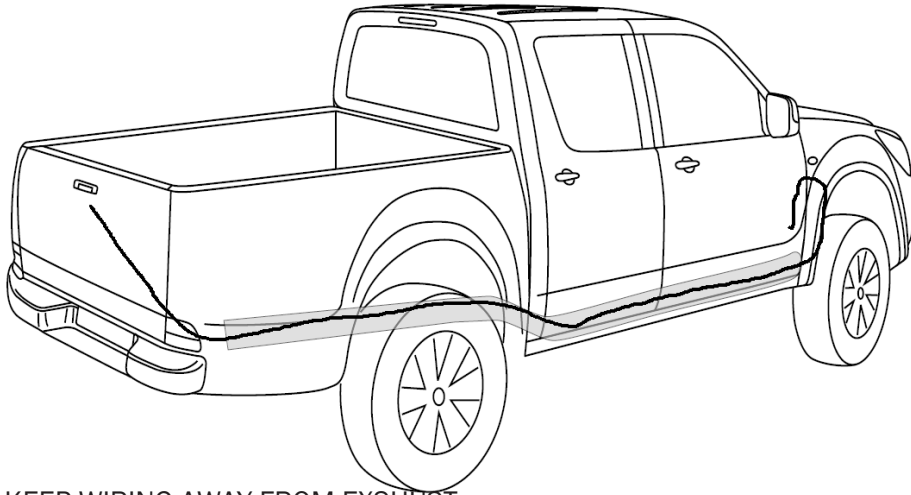

NOTE: KEEP WIRING AWAY FROM EXSHUST

Step 18

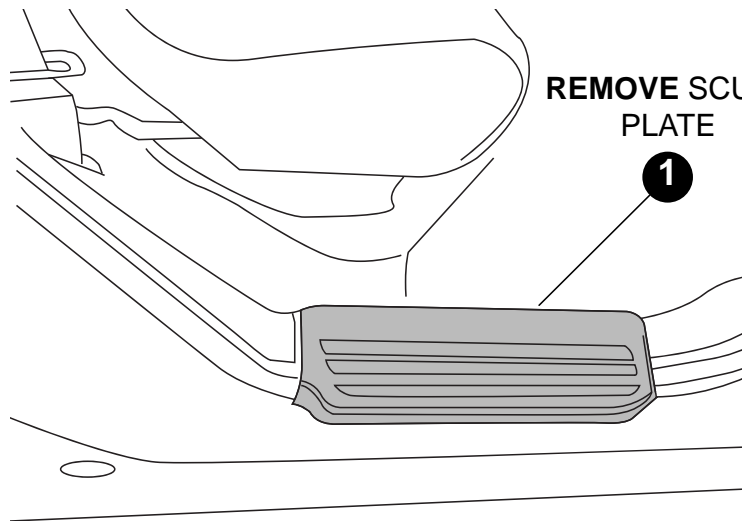

REMOVE SCUFF
PLATE

1

— Step 19 —

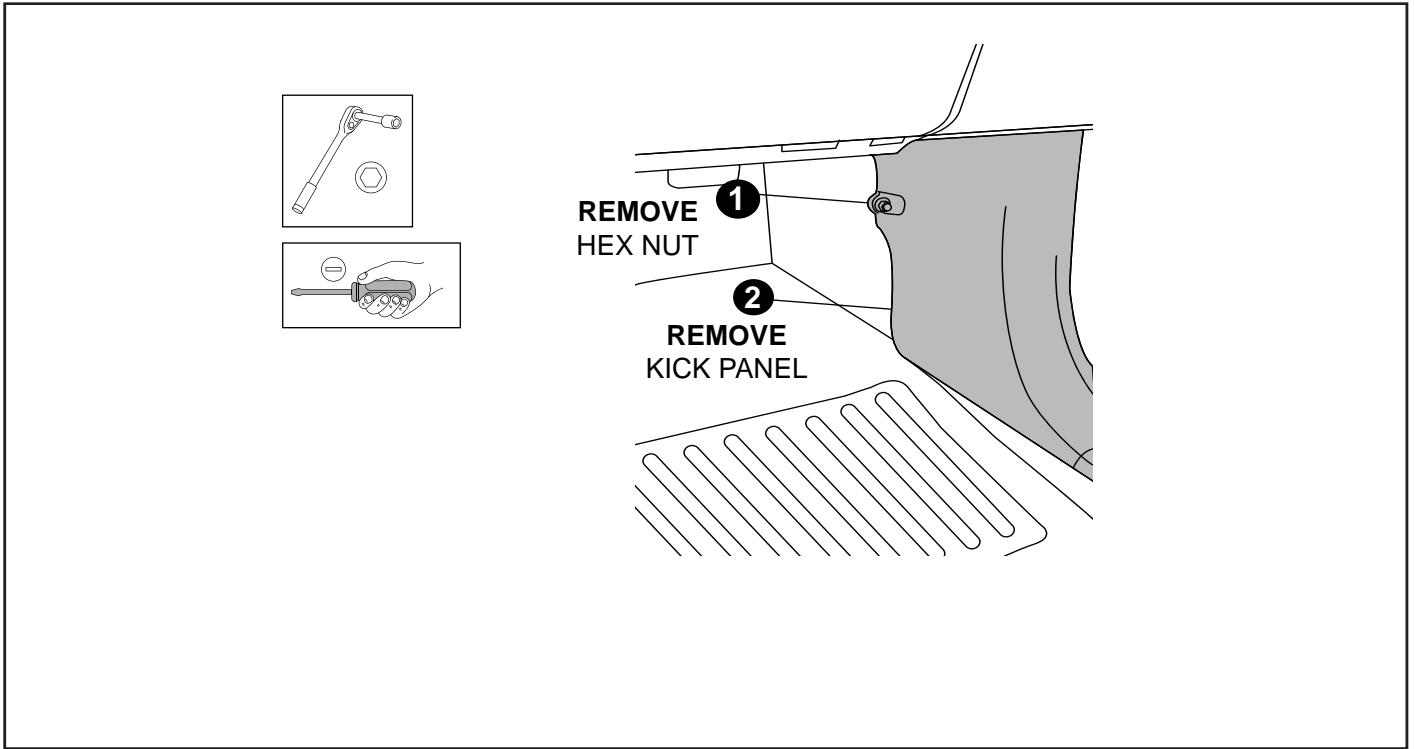

— Step 20 —

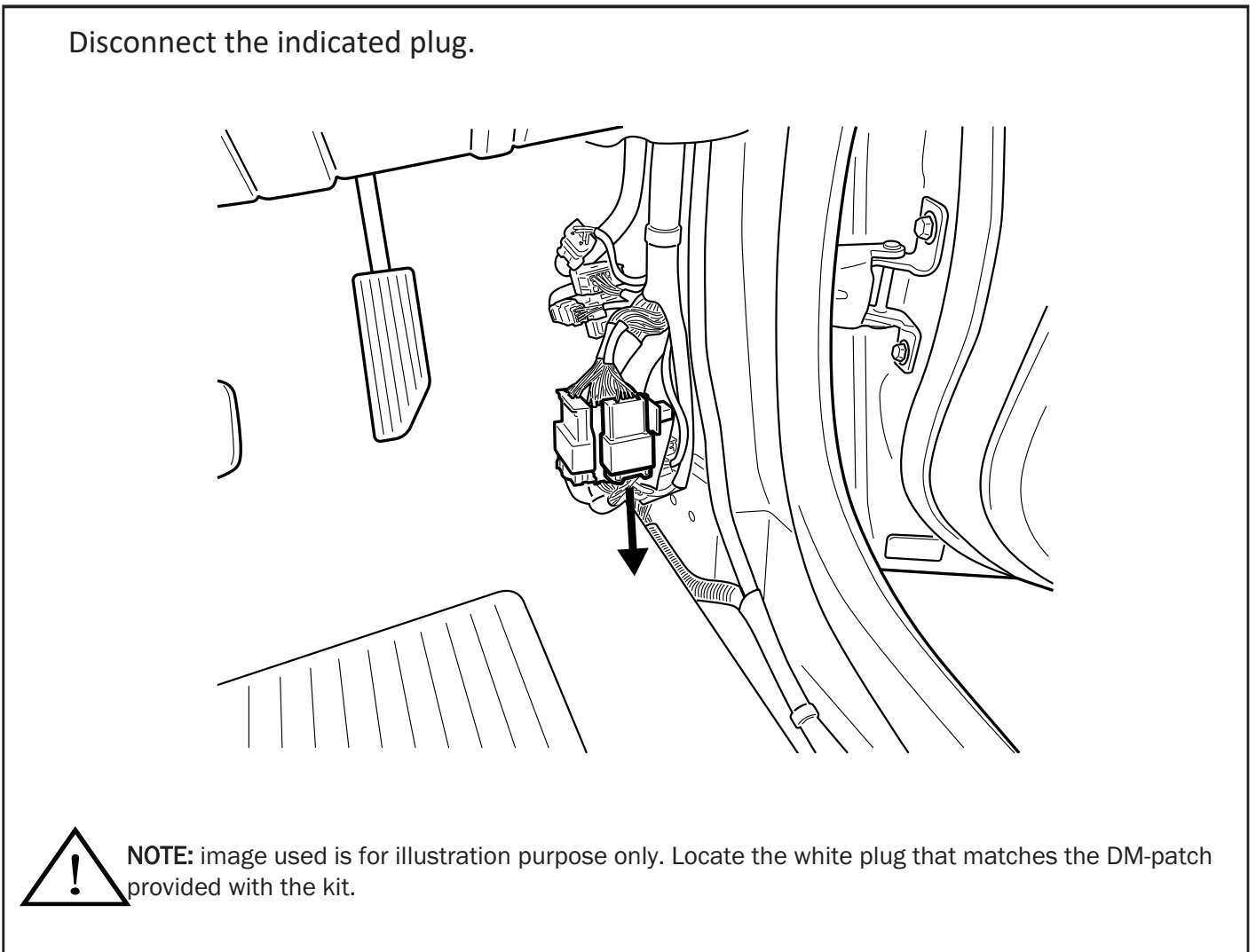

— Step 21 —

Connect DM-PATCH to the vehicle harness.

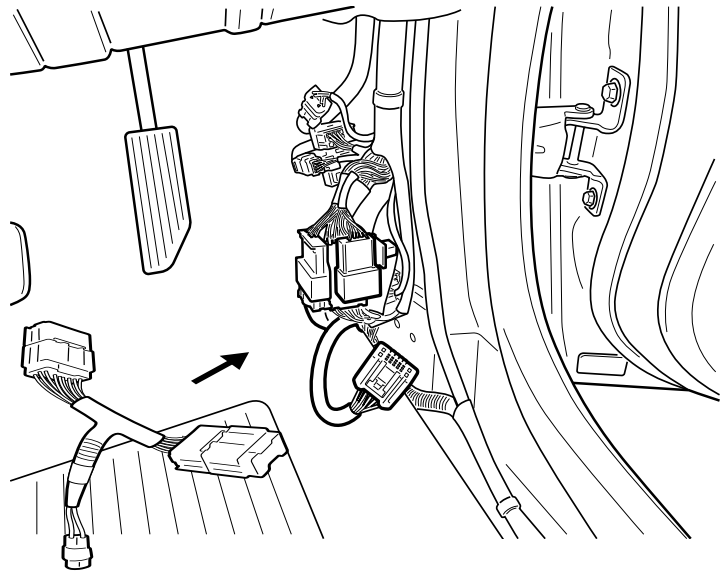

— Step 22 —

Plug CL-LOOM-LONG to DM-PATCH wiring.

Cable tie overhang of wires and assemble all panels removed earlier.

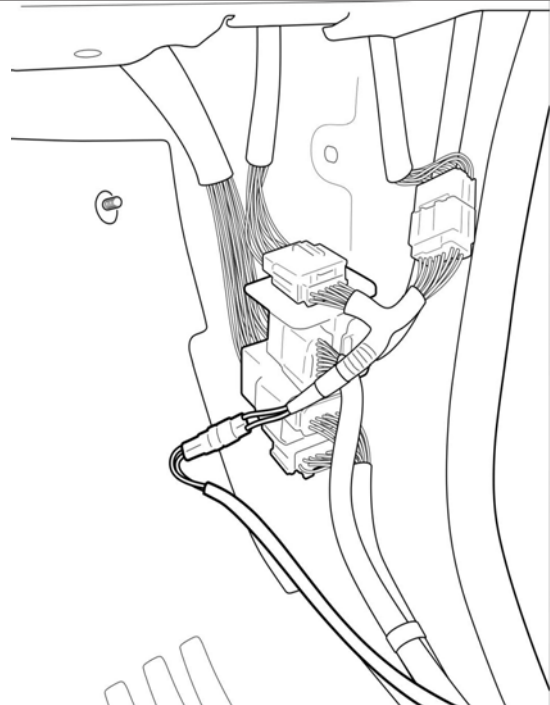

NOTE: image used is for illustration purpose only.

Place and fasten tail gate cover.

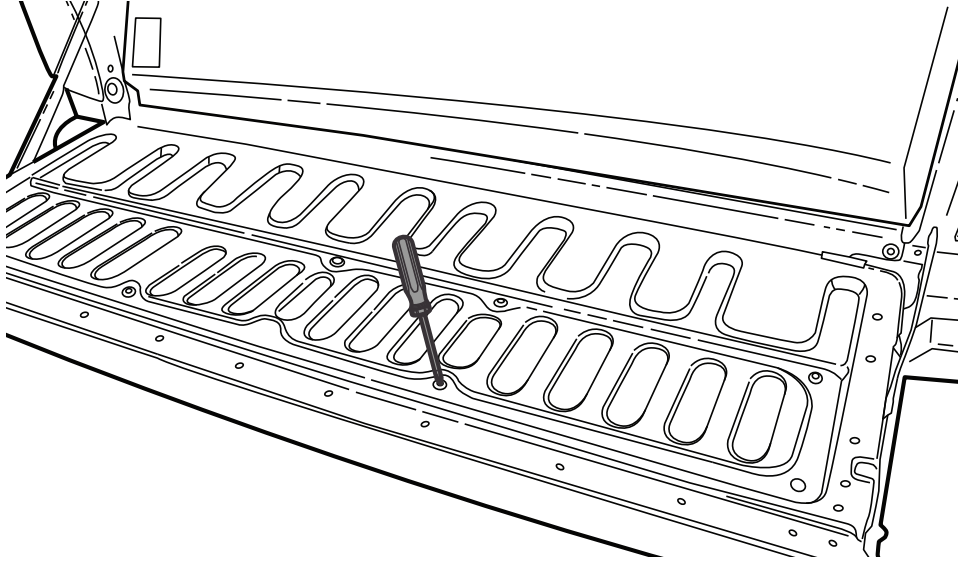

— FITTING COMPLETED —
