

24

INSTALACIÓN BISAGRAS/ HINGES INSTALLATION

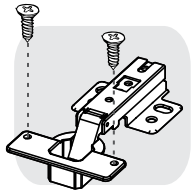

Bisagra parche/
Full overlay hinge

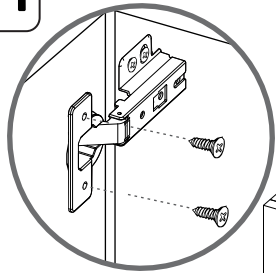
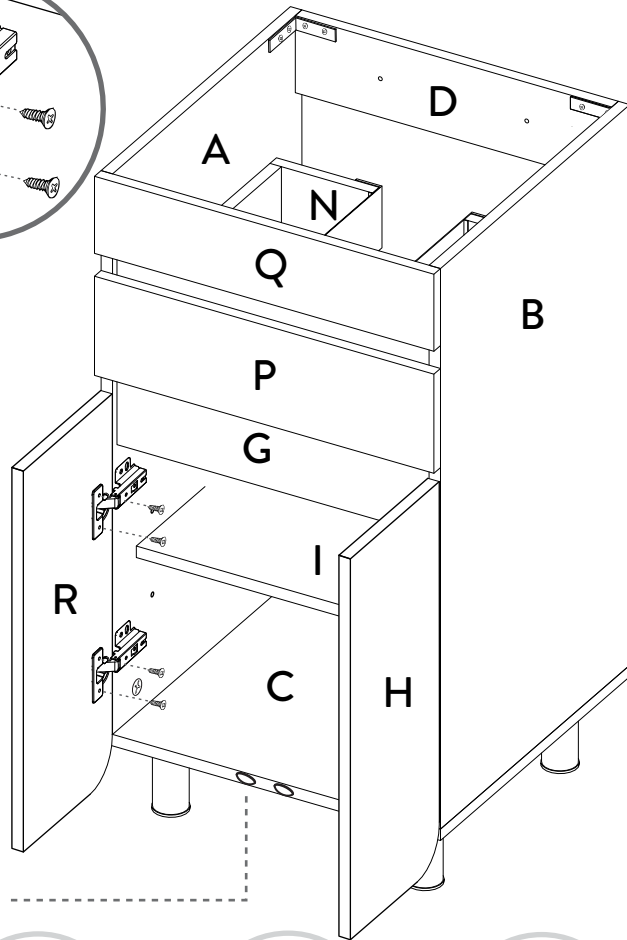

Tope burbuja

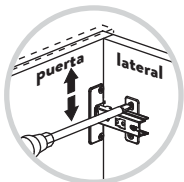

AJUSTE DE ALTURA /
HEIGHT ADJUSTMENT

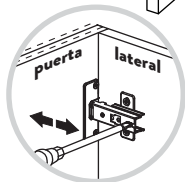

AJUSTE DE PROFUNDIDAD /
DEPTH ADJUSTMENT

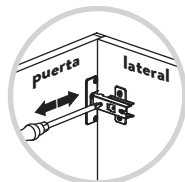

AJUSTE LATERAL /
LATERAL ADJUSTMENT



Al terminar de armar desprenda los adhesivos (en caso de que queden residuos de pegamento, limpie la superficie con alcohol) / When you finish assembly, off adhesive (in case of residues of glue, wipe it with alcohol)



Al finalizar el ajuste de los conectores, proceda a poner las tapas adhesivas / When you finish the adjustment of the connectors, proceed to put the cover tapes

INSTRUCCIONES DE ENSAMBLE
/ASSEMBLY INSTRUCTIONS

MUEBLE ALUVIA 60 X 45

/ ALUVIA 60 X 45 VANITY

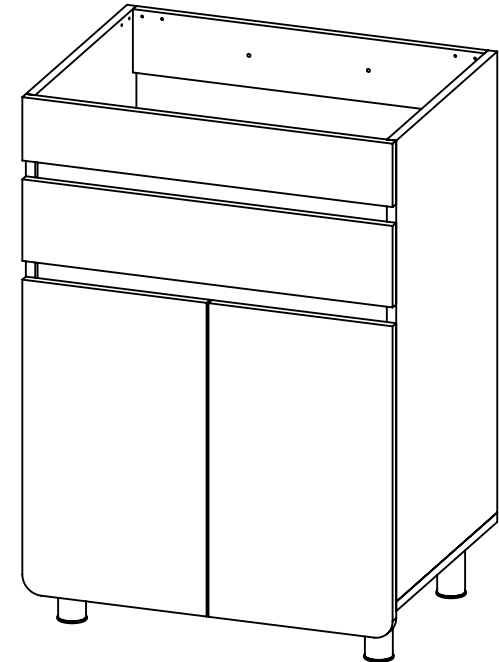

Alto: 85 cm
Ancho: 59,5 cm
Fondo: 44.5 cm

LOTE No: _____

BAÑOS Y COCINAS



Línea de atención
Bogotá: 404 88 84
Colombia: 01 8000 51 20 30
Otros países: +57 (1) 404 88 84

Customer service
+57 (1) 404 88 84
corona.CO



“Lea muy bien el instructivo antes de armar el producto, ármelo en un lugar limpio y preferiblemente en una superficie plana”



RECOMENDACIONES IMPORTANTES KEY RECOMMENDATIONS

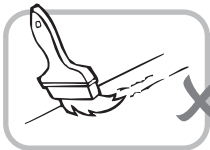

NO pinte el mueble /
Don't paint the
furniture.

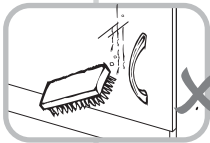

NO lavar las manijas o
tiraderas con jabones o
elementos abrasivos /
Don't wash handles
or dumps with soap or
abrasives.

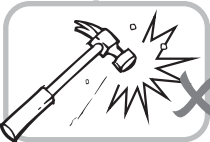

NO golpear ni martillar
el mueble (hágalo sólo
donde se indique) /
Don't hit or hammer
the furniture (just do it
where indicated).

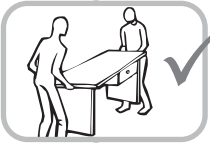

SIEMPRE levante el mueble
entre dos personas, **NO lo**
arrastre / Don't drag the
furniture. Lift it between
two people.

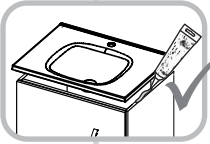

SE RECOMIENDA aplicar
silicona en el empalme entre
el lavamanos y el mueble para
evitar filtraciones de agua /
To avoid water leaks it is
recommended to apply
silicone between the cabinet
and the sink.



NO ubicar a la intemperie /
Don't expose to rain
or direct sun.

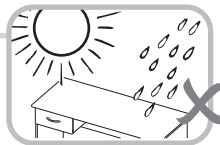

NO mojar o evitar chorro
de agua directo, en tal caso
secar con un trapo /
Don't wet or avoid splash
water directly, in such
case wipe dry.

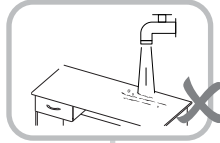

NO sobrecargue el mueble.
no exceda el peso de 30 kilos
para gabinetes de cocina /
Don't overload the cabinet.
Weight not exceeding 66LB
for kitchen cabinets.



NO permita que los niños
manipulen el mueble, puede
voltearse y lastimarlos /
Don't allow children to handle
the cabinets or drawers.



Limpie con paño seco y
lustrador de muebles,
de esta forma alarga la
vida del mueble / Clean with
a dry cloth. Polishing wax for
furniture can be use.

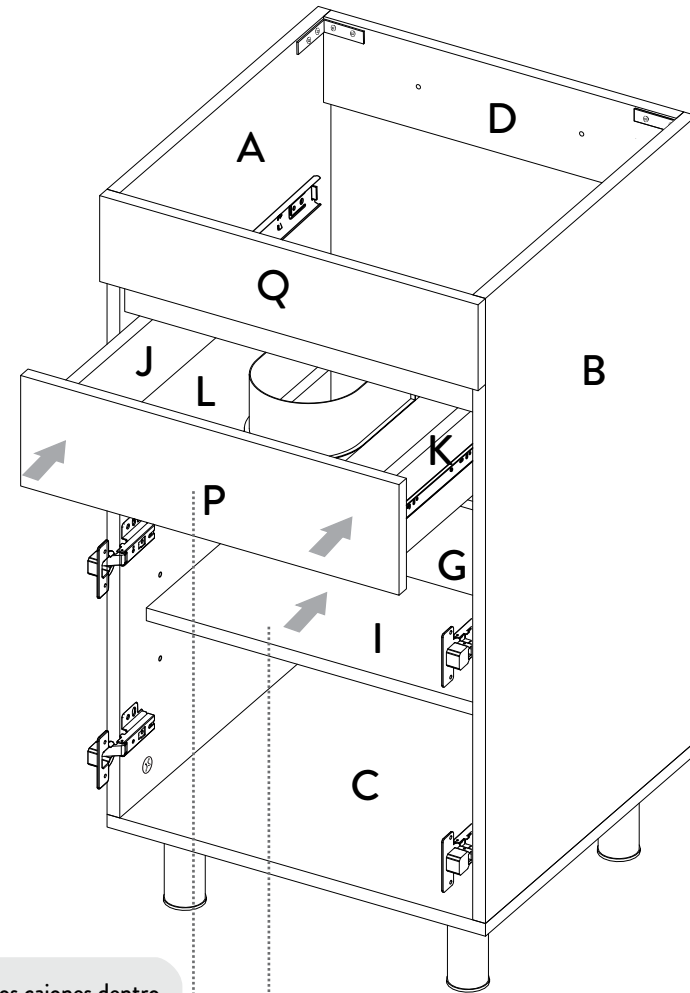

Deslice los cajones dentro
del mueble/ Slide the
drawers inside the cabinet

Deslice el entrepaño dentro
del mueble/ Slide the
shelf inside the cabinet

22



**PARA INSTALAR A PARED
WALL INSTALLATION**

* Herramientas
NO incluidas/
Tools not
included



Utilizar una broca de 5/16" para hacer las perforaciones en el muro/
Use a 5/16" drill bit to drill the wall.

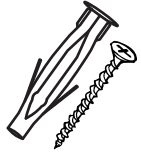

Tornillo 2" + Chazo Mariposa/
Wall Anchor

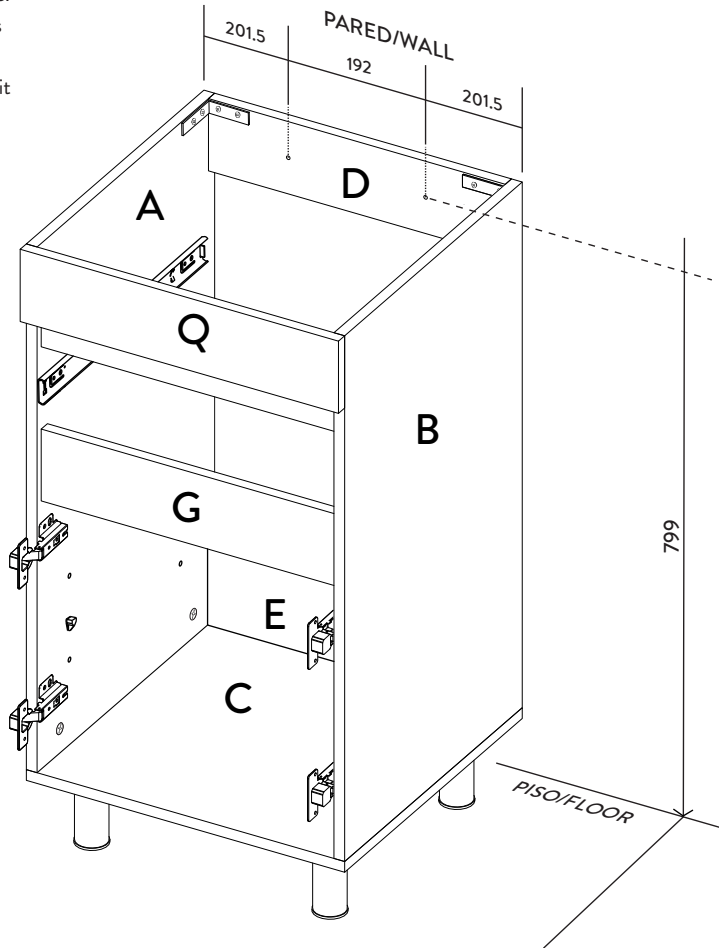

IMPORTANTE

Medir y marcar las distancias, como muestra la figura, recuerde que las perforaciones deben estar alineadas / Take measures and distances, as shown in the figure, remember that the holes must be aligned.



*Medidas en milímetros /
Measured in millimeters

No olvide poner las tapas adhesivas en donde quedan visibles/ Don't forget to stick the cover caps where visible

RECOMENDACIONES DE ENSAMBLE

De un adecuado armado del mueble depende su buen funcionamiento.
Following the cabinet assemble instructions will assure its proper functioning.

MINIFIX

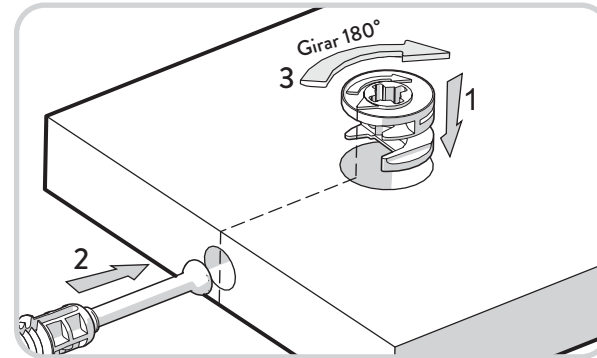

TARUGOS



GARANTÍA: Este mueble para baño CORONA® tienen una *garantía de 1 año* en partes de madera y en herrajes, a partir de la fecha de compra.

La garantía cubre defectos de fabricación y mala calidad de materiales que impidan el armado y uso del mueble. Dado el caso se reemplazará la(s) pieza(s) defectuosa(s). El tablero melamínico no se despega siempre y cuando cumpla estrictamente las recomendaciones sobre el cuidado del producto. Estos están inmunizados.

Examine completamente las piezas antes de ensamblar, una vez armado el mueble, la empresa NO se hará responsable por piezas dañadas. La garantía NO aplica para productos que hayan sido armados incorrectamente, manipulados o utilizados de manera no razonable, modificados, reparados, o que hayan sido sobrecargados o expuestos a chorro de agua directa o hayan omitido alguna de las recomendaciones establecidas. No incluye mano de obra para el ensamble del mueble. Esta garantía aplica únicamente bajo condiciones normales de uso y manipulación.

Para hacer válida la garantía, comuníquese con nuestra línea de atención al cliente de CORONA.



Línea de atención

Bogotá: 404 88 84
Colombia: 01 8000 51 20 30
Otros países: +57 (1) 404 88 84
Customer service
+57 (1) 404 88 84



corona.CO

HERRAJES PARA ARMADO

ASSEMBLY HARDWARE

x27

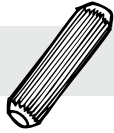

Tarugo/
Fluted dowel pin

x26

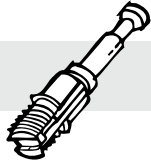

Perno minifix/
Spreading bolt

x26



Minifix/
Minifix connector

x24



Tapa adhesiva
color 1/
Cover Caps

x4



Soporte entrepaño/
Shelf support

x4



Tapa adhesiva
color 2/
Cover Caps

x2



Tope burbuja/
Bum Pum stop

x4

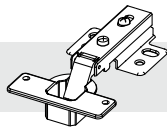

Bisagra Parche
Slide On/
Full Overlay hinge

x1



Riel Extensión
Total 35 cm/
Full Extension Drawer Slides

x1

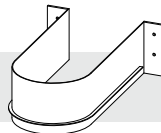

Pieza plástica
en U grande/
Plastic U accessory
large size

x36



Tornillo lámina/
Sheet Metal screw

x4

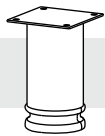

Pata acero/
Steel leg

x2

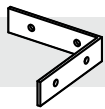

Platina en L/
Angle Brackets

x2



Chazo Mariposa/
Taquete+ Tornillo
ensamble 2" 1/2
/ Plastic wall anchor



IMPORTANTE

TENER PRECAUCIÓN AL ABRIR LA BOLSA DE HERRAJES PARA NO EXTRAVIAR NINGUNO. COMPRUEBE QUE EL CONTENIDO DE LAS PIEZAS SEA EL CORRECTO. EN CASO QUE FALTE ALGUNA PIEZA O ESTE DEFECTUOSA LE AGRADECEREMOS LLAMAR DE INMEDIATO A LA LÍNEA DE ATENCIÓN EN COLOMBIA: 01 8000 51 20 30 -BOGOTÁ: 404-88 84 - PARA OTROS PAÍSES: + 57 (1) 404 88 84 - SERVICIO AL CLIENTE: + 57 (1) 404 88 84

20



Girar 180° /
Rotate 180°

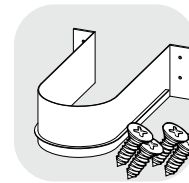
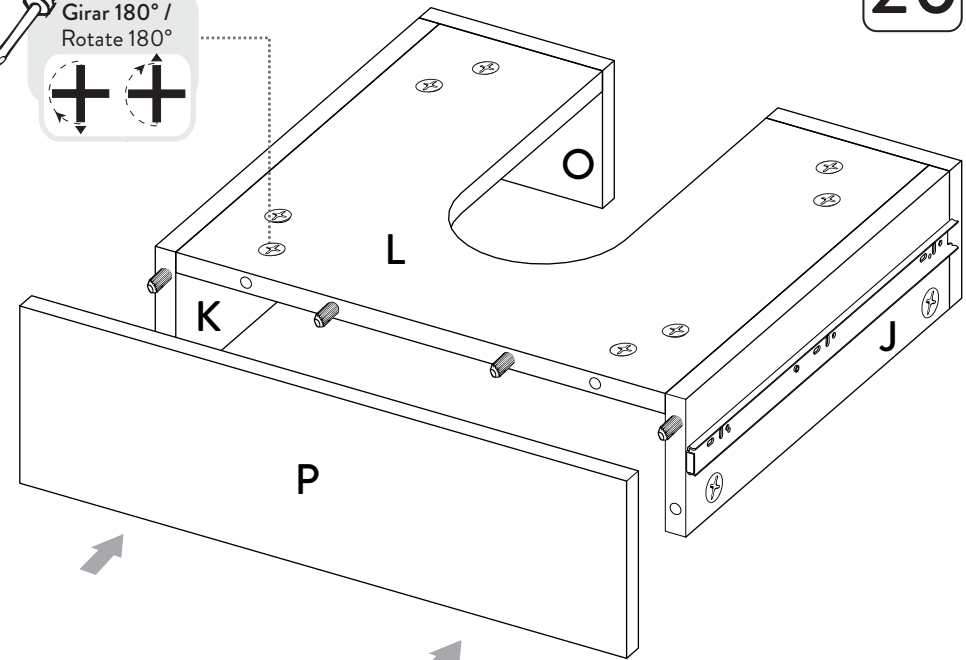

21

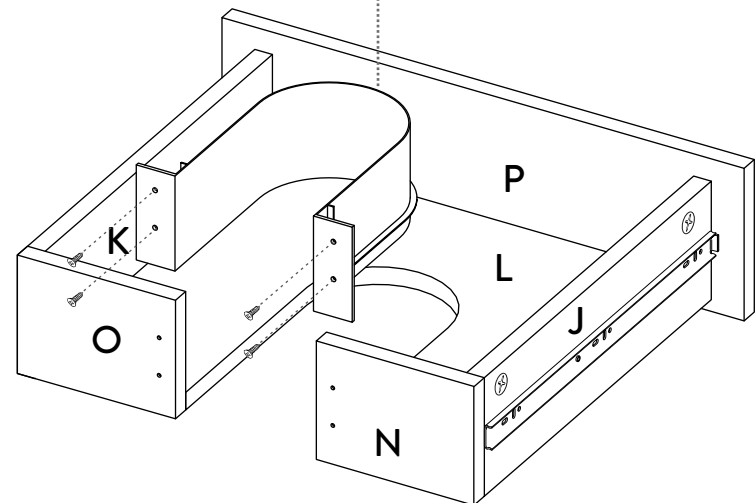

18

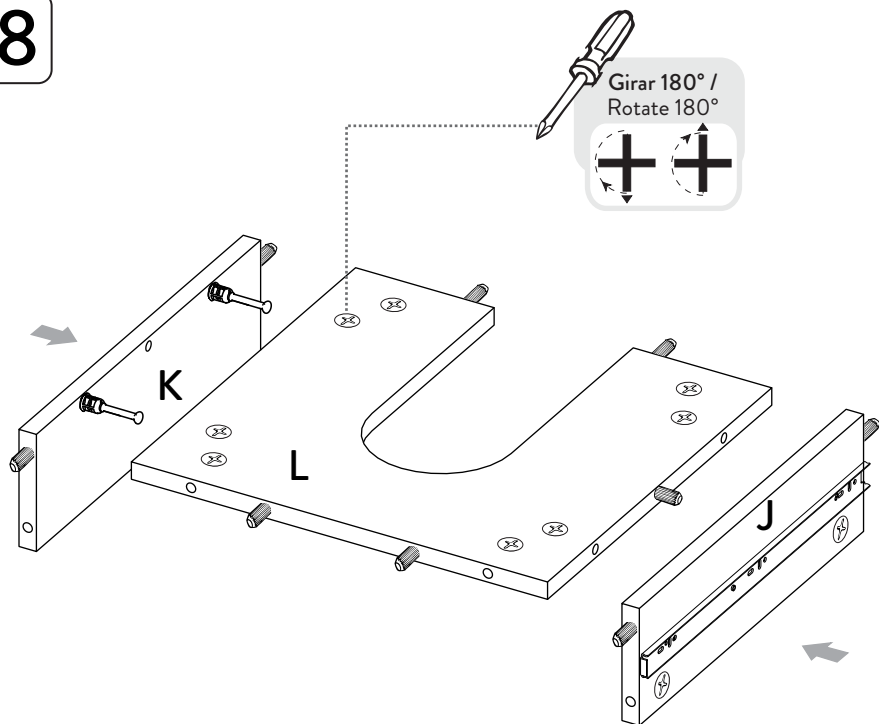

19

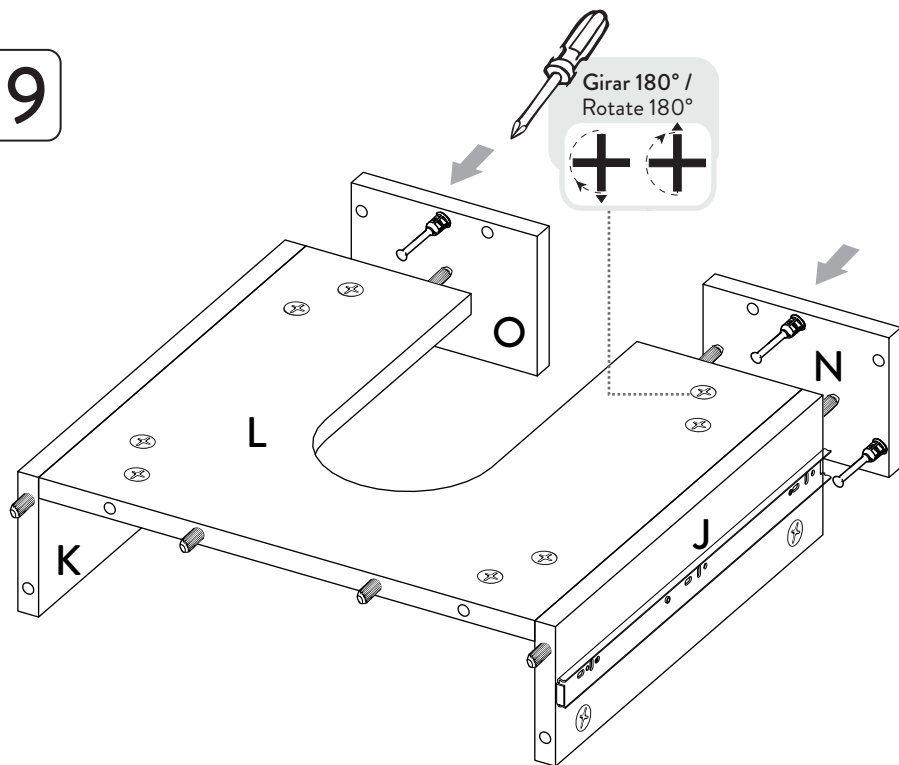

CARGAS MÁXIMAS SUGERIDAS

MAX SUGGESTED LOADS

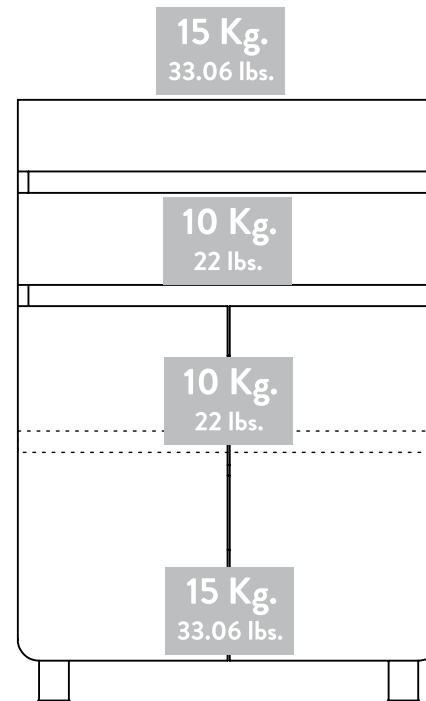

PIEZAS DE ARMADO

ASSEMBLY PARTS

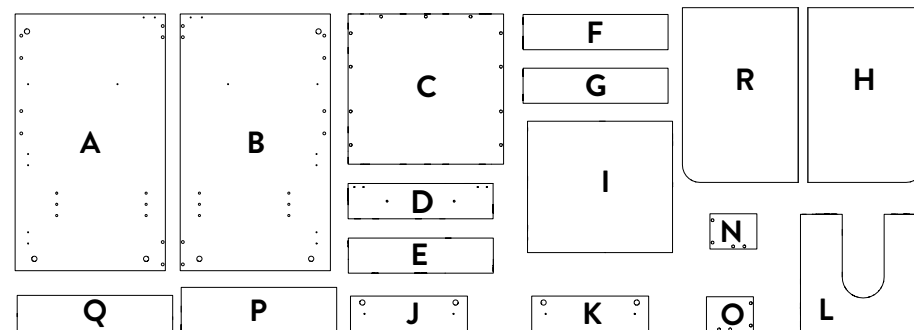

TENER PRECAUCIÓN AL ABRIR LA BOLSA DE HERRAJES PARA NO EXTRAVIAR NINGUNO. COMPRUEBE QUE EL CONTENIDO DE LAS PIEZAS SEA EL CORRECTO. EN CASO QUE FALTE ALGUNA PIEZA O ESTE DEFECTUOSA LE AGRADECEMOS LLAMAR DE INMEDIATO A LA LÍNEA DE ATENCIÓN EN COLOMBIA: 01 8000 51 20 30 -BOGOTÁ: 404-88 84 - PARA OTROS PAÍSES: + 57 (1) 404 88 84 - SERVICIO AL CLIENTE: + 57 (1) 404 88 84

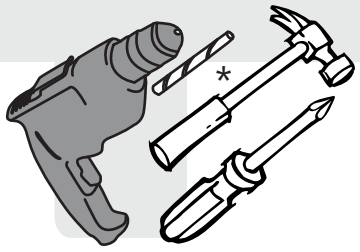

- Taladro/ Drill
- Broca de muro de 5/16" / 5/16" Drill bit.
- Destornillador de estrella/ Star Screwdriver
- Destornillador de pala/ Flat Screwdriver

*(Herramientas NO incluidas)/
(Tools not included)

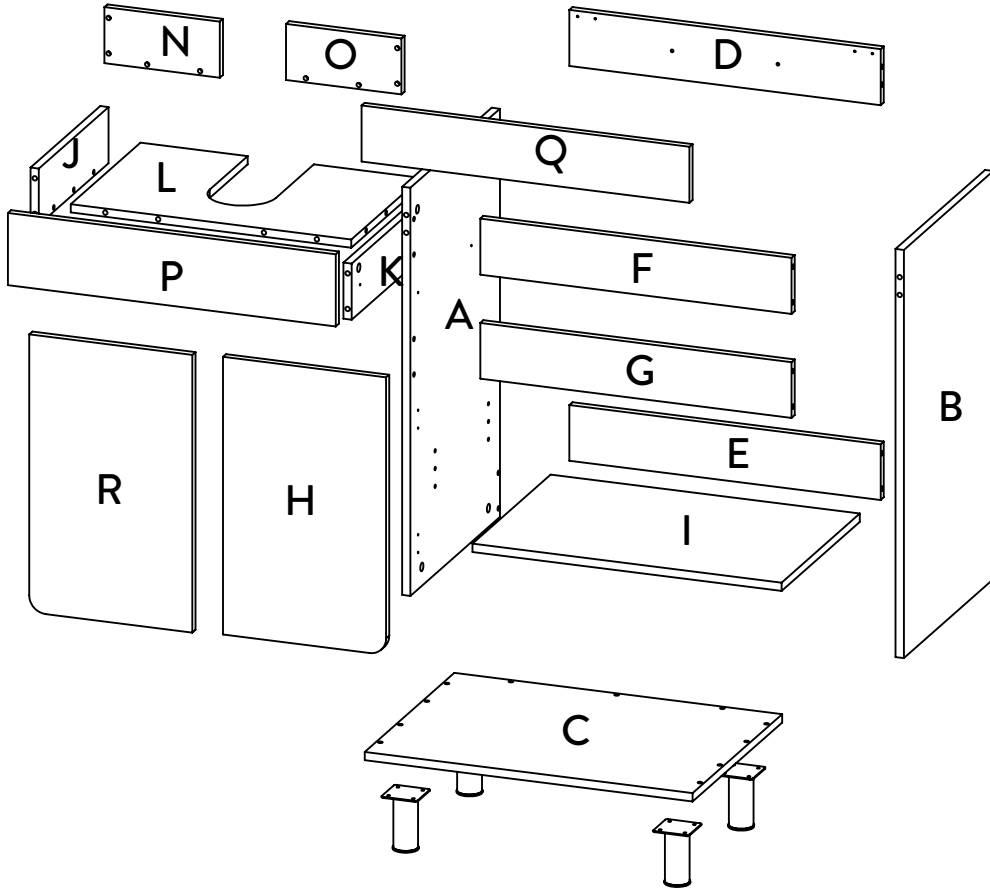

16

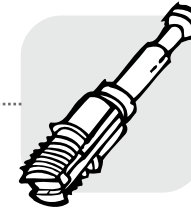
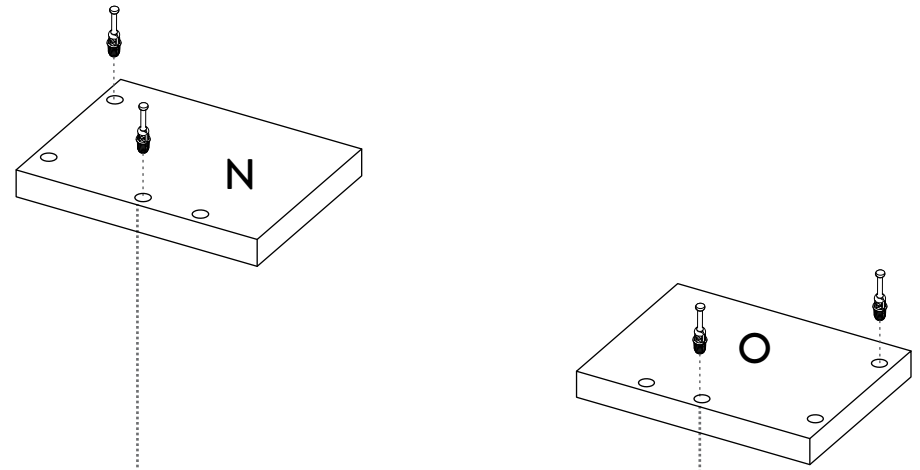

17

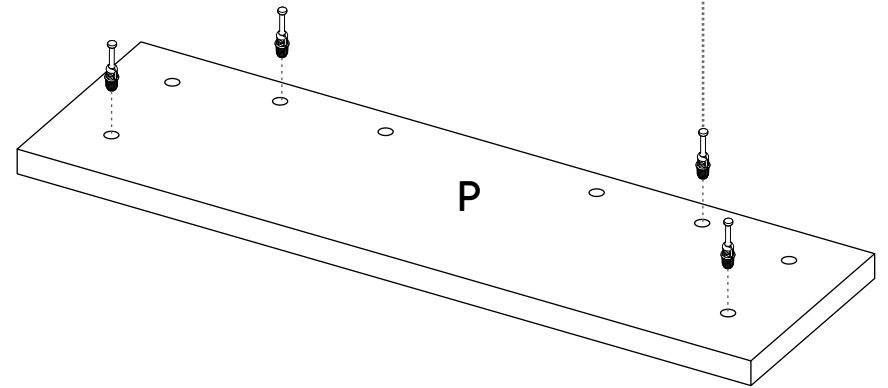

14



PARA PONER RIEL EN LATERAL DEL CAJÓN/

When placing the slide on the side of the drawer:
Revisar que el tope metálico del riel quede en la PARTE DELANTERA/
The metallic stop should be placed on the front.

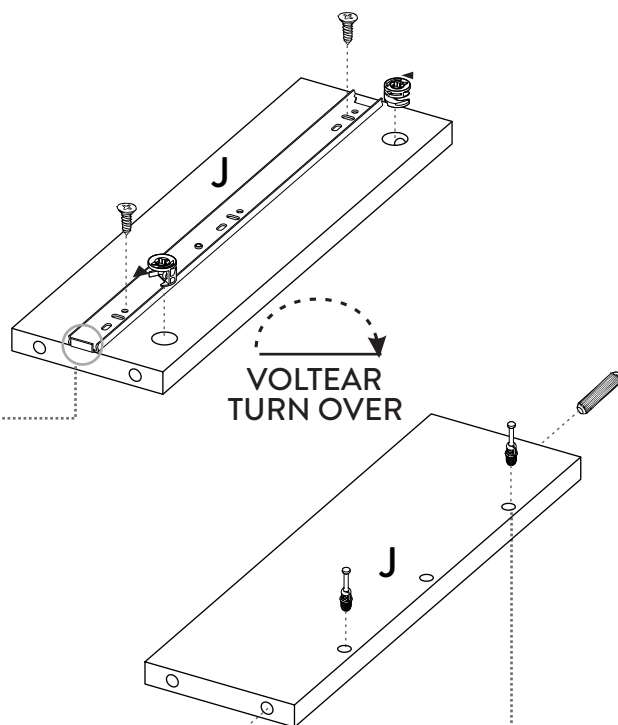

15



PARA PONER RIEL EN LATERAL DEL CAJÓN/

When placing the slide on the side of the drawer:
Revisar que el tope metálico del riel quede en la PARTE DELANTERA/
The metallic stop should be placed on the front.

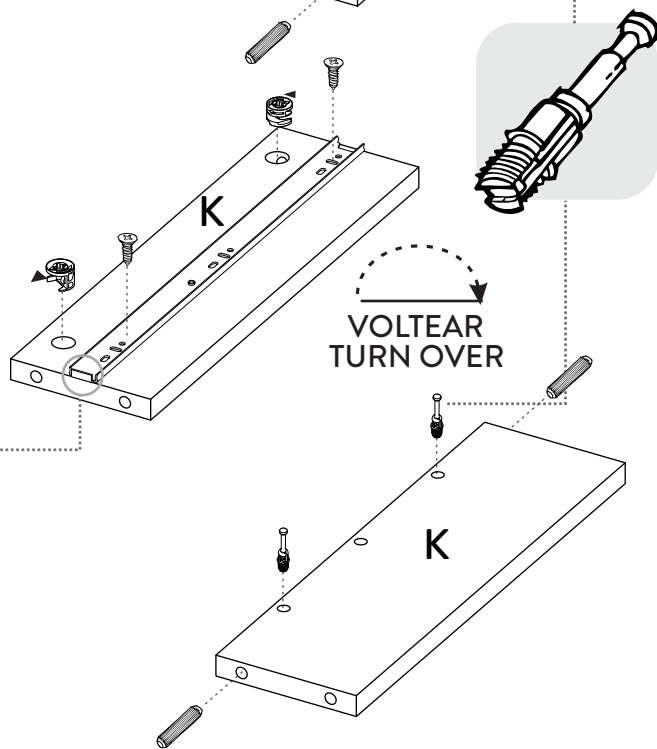

Leer las recomendaciones de ensamble antes de comenzar con el armado del mueble /
Read the assembly instructions before starting the assemble of the cabinet.

1

Se recomienda armar el mueble sobre la caja o sobre una superficie lisa para no rayarlo; y con la ayuda de otra persona / It's recommended to assemble the cabinet above the box or on a flat surface to not scratch it and with the help from another person

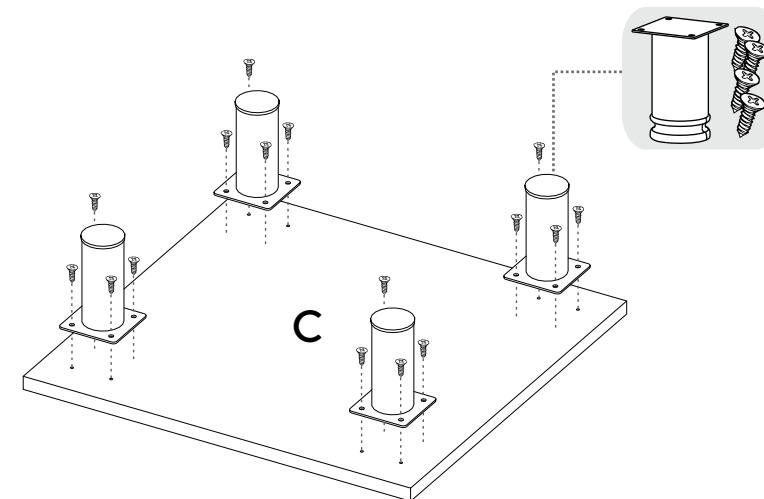

VOLTEAR
TURN OVER

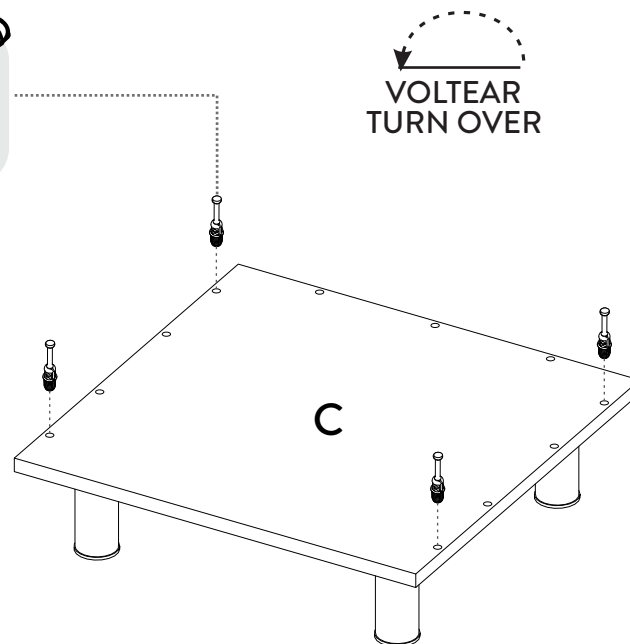

2

3



**PARA PONER RIEL EN LATERAL DEL MUEBLE/
TO PUT THE DRAWER SLIDE ON THE SIDE OF THE FURNITURE:**

Revisar que el **tope plástico** del riel quede en la **PARTE TRASERA**!
The plastic stop should be placed on the rear.

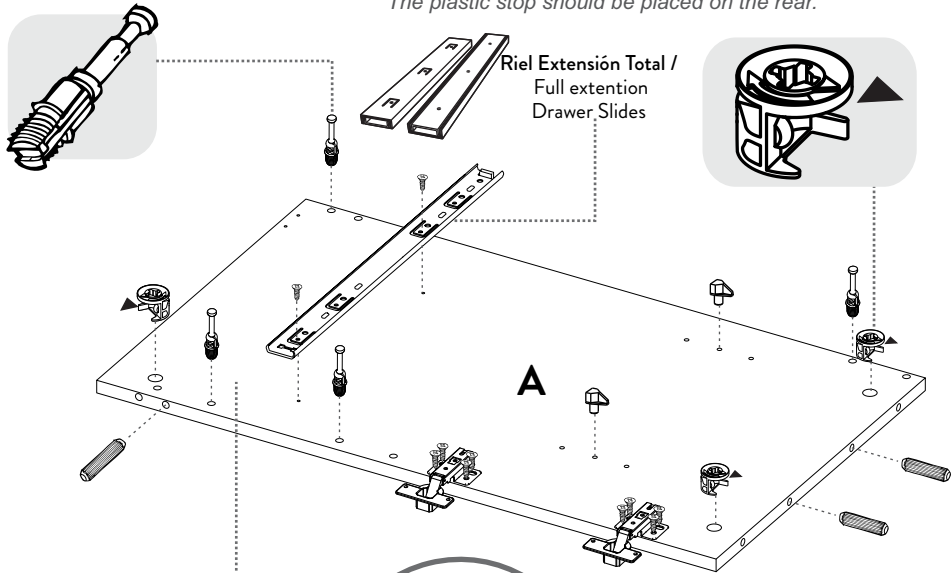

Riel Extensión Total /
Full extension
Drawer Slides

4

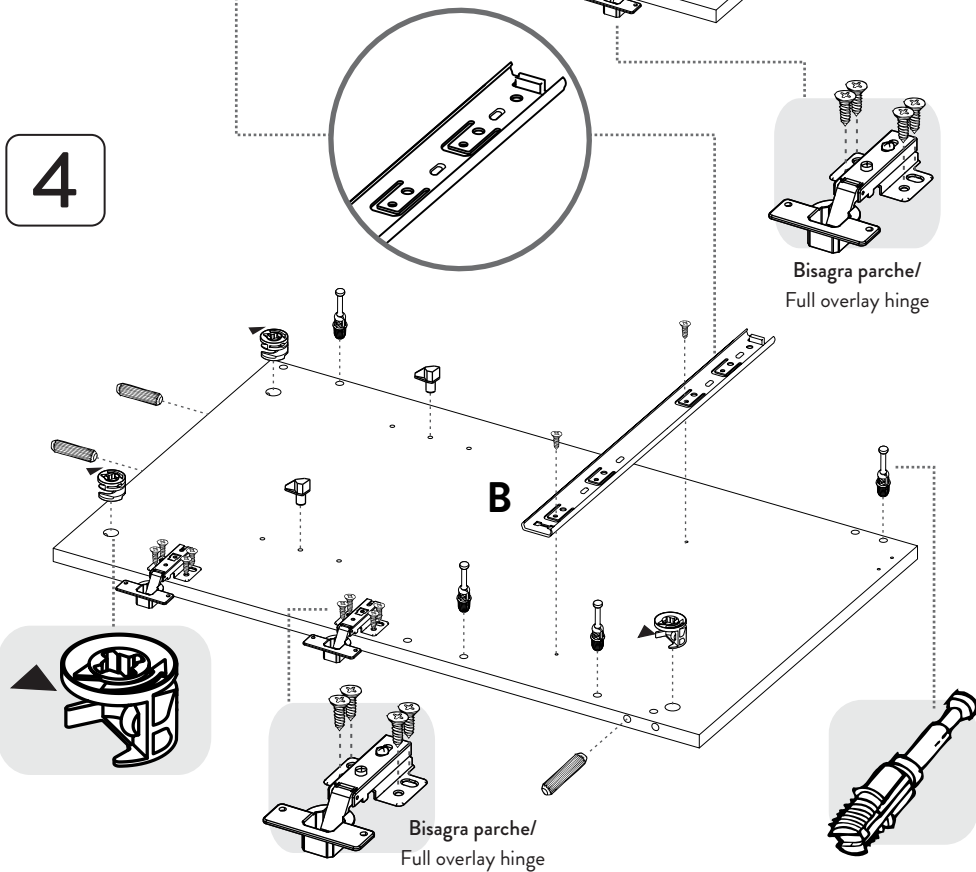

Bisagra parche/
Full overlay hinge

Bisagra parche/
Full overlay hinge

12



Girar 180° /
Rotate 180°

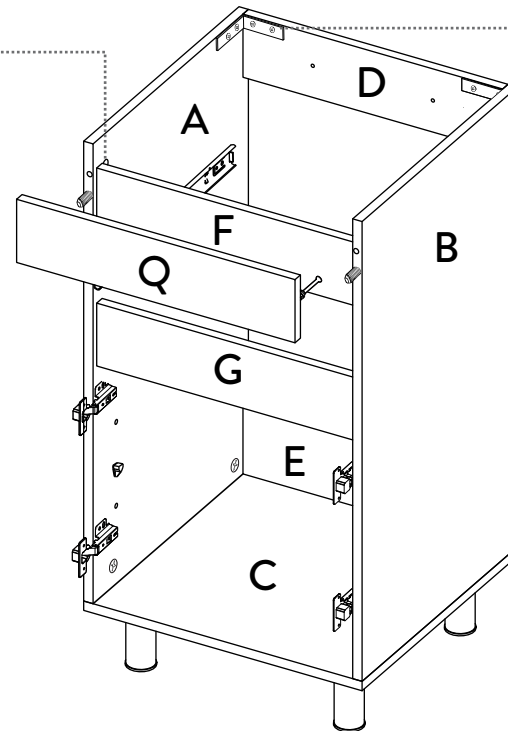

Platina en L/
Angle Brackets

13

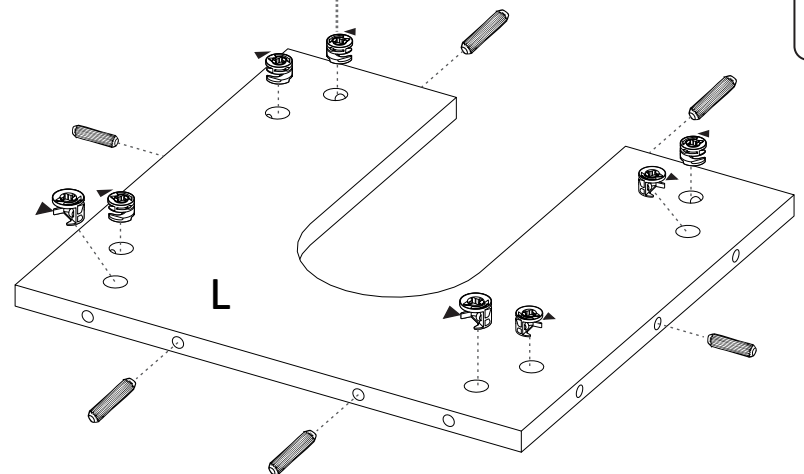

11

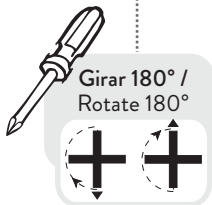
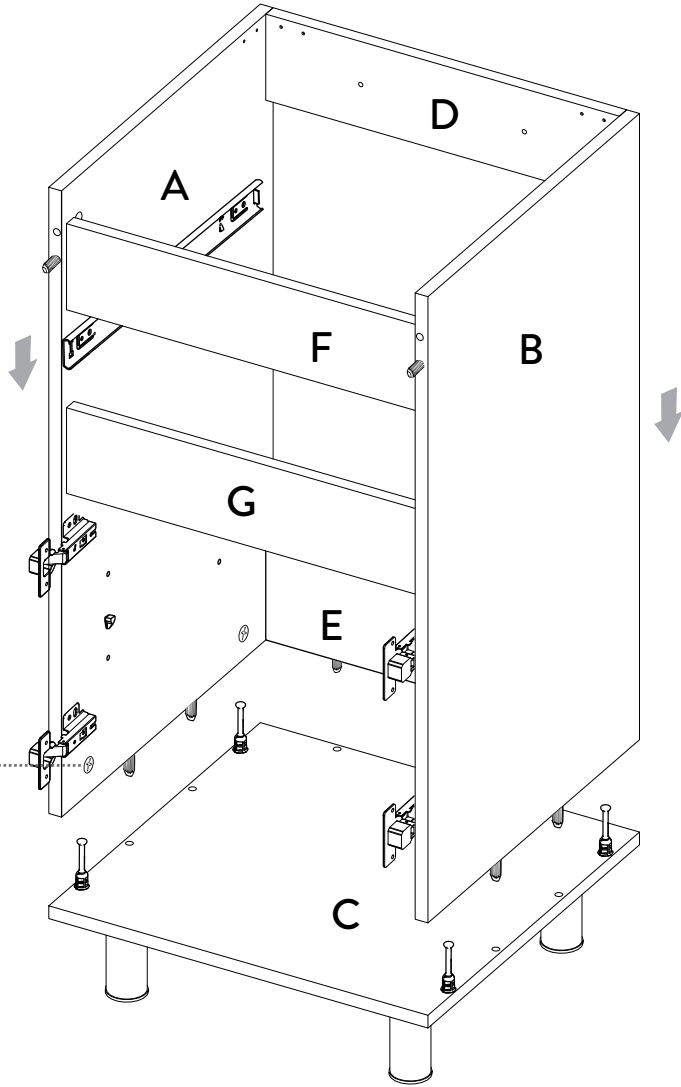

5

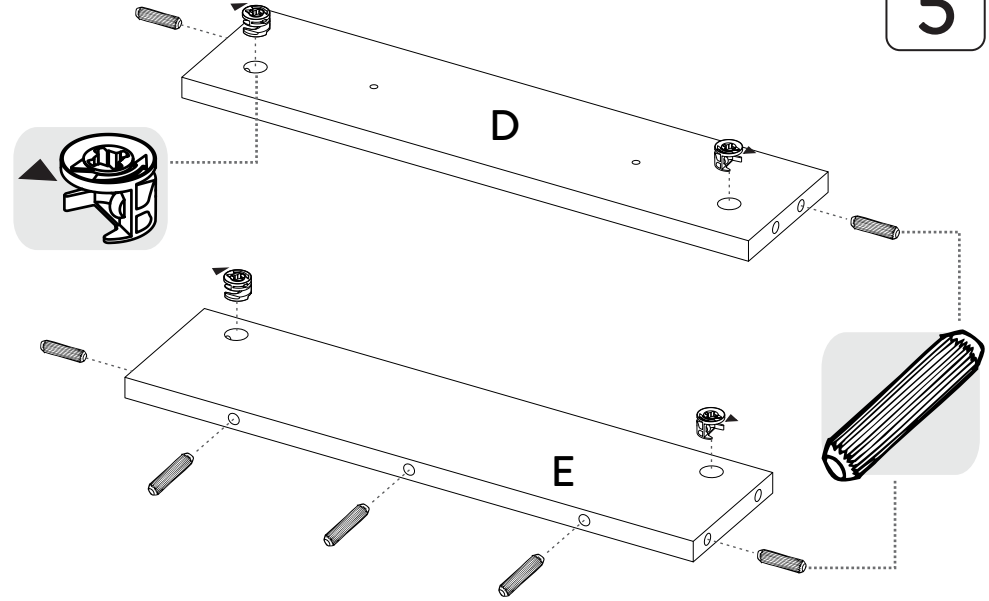

6

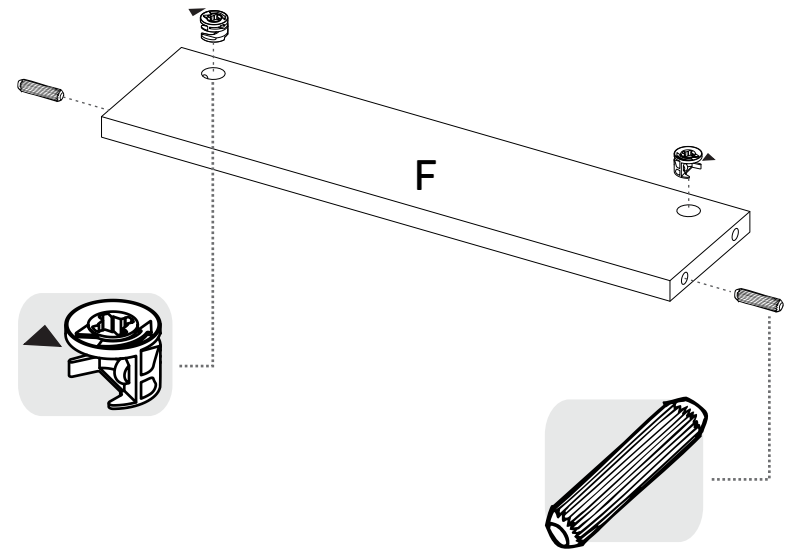

7

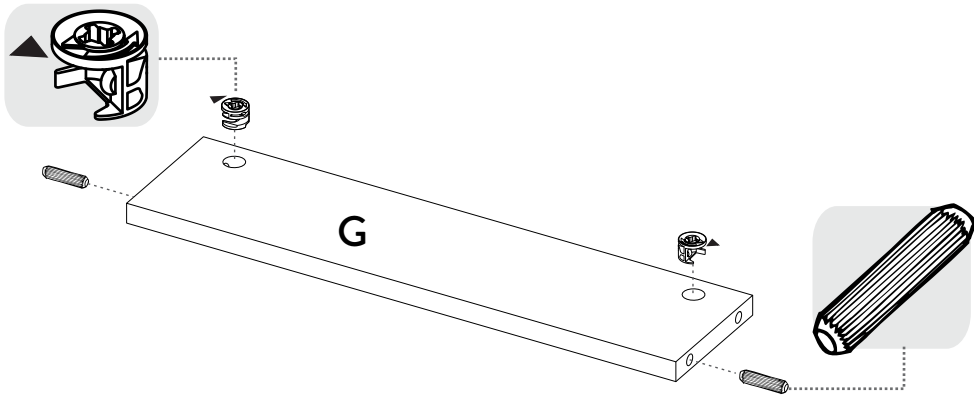

8

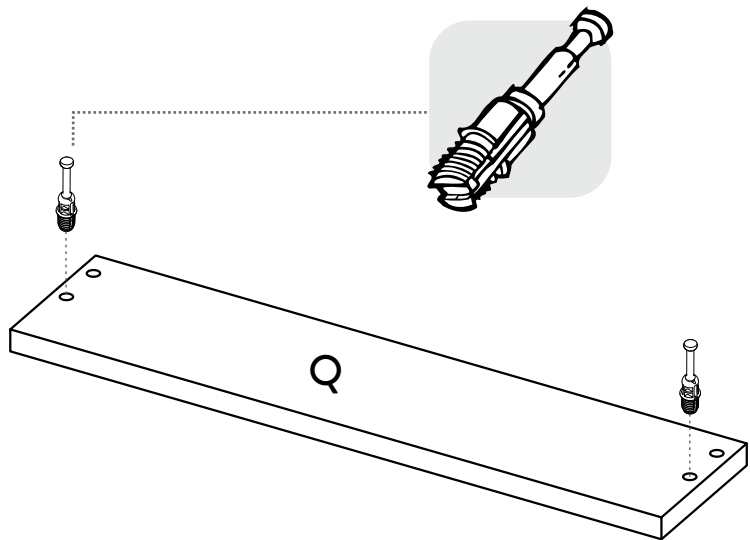

9

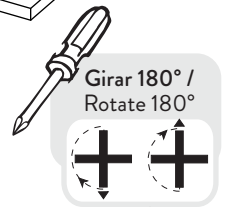
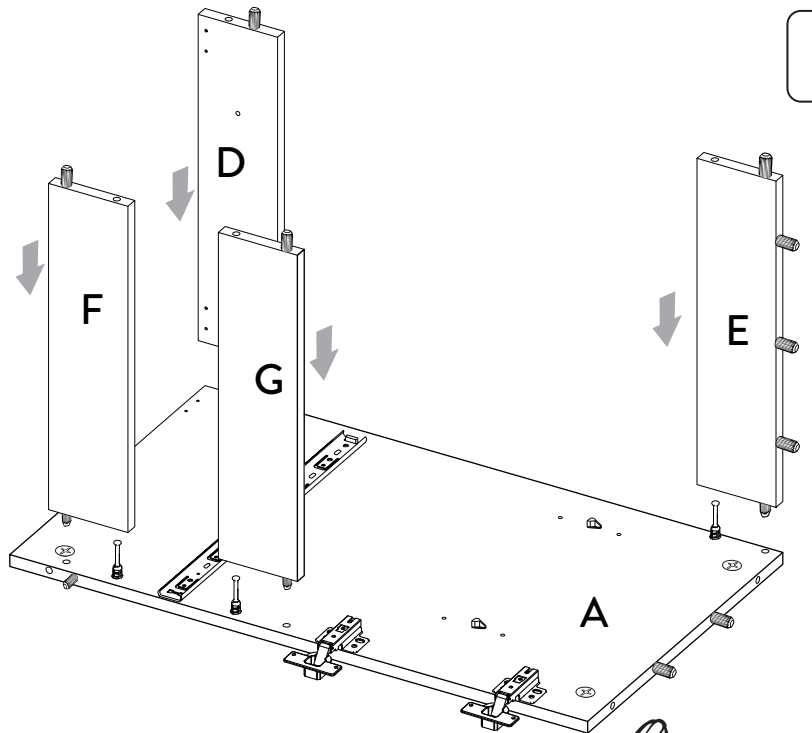

10

