

Ubique el mueble debajo del lavamanos como lo indica la figura/Position the cabinet under the sink as shown in figure

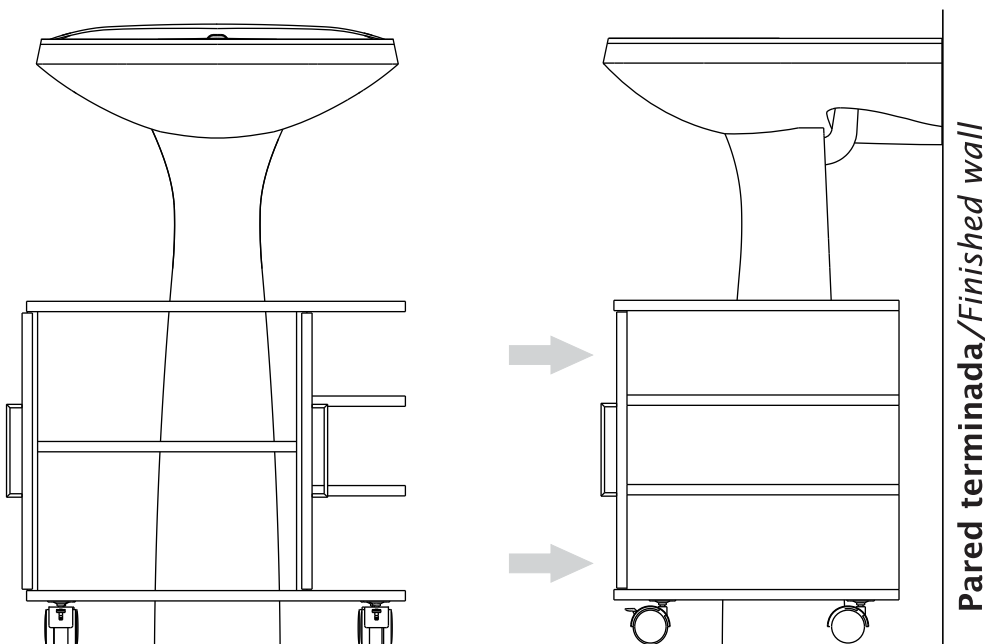

Piso terminado/Finished floor

Pared terminada/Finished wall

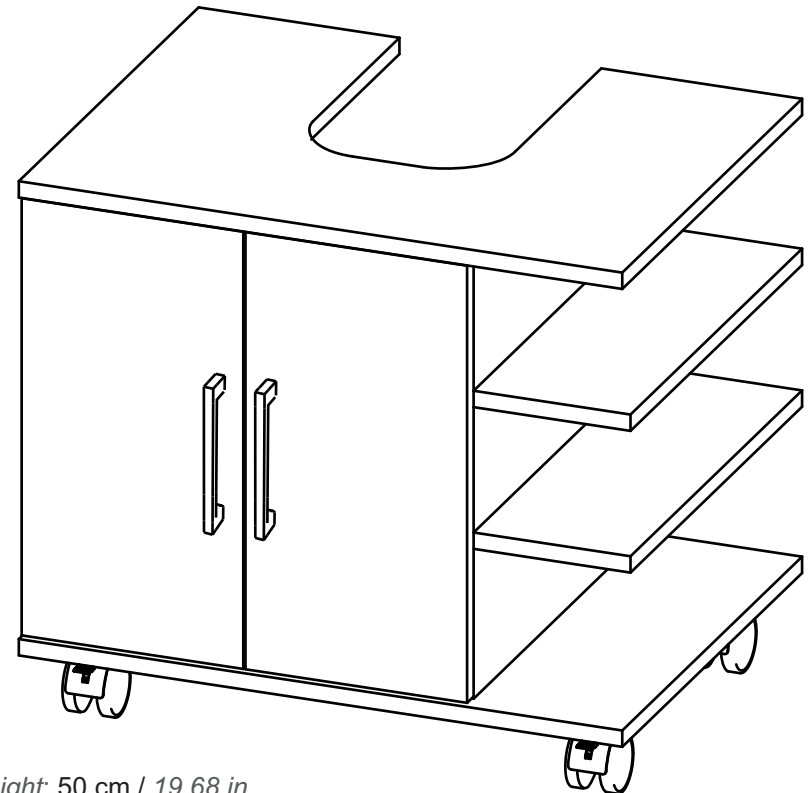

Alto/ Height: 50 cm / 19,68 in
Ancho/ Width: 55 cm / 21,65 in
Fondo/ Depth: 41,4 cm / 16,29 in

LOTE No: _____



Al finalizar el ajuste de los conectores, proceda a poner las tapas adhesivas/
When you finish the adjustment of the connectors, proceed to put the cover tapes



Al terminar de armar, desprenda los adhesivos (en caso de que queden residuos de pegamento, limpie la superficie con alcohol) / After finish assembling, tear off the adhesives. (In case of glue residues, wipe them with alcohol)

By: **RTA**® TEL (572) 691 17 00
m u e b l e s PBX (572) 695 91 81
CALI - COLOMBIA
www.rta.com.co

**MUEBLE PARA LAVAMANOS
ELEMENTAL**
/Elemental Vanity

RECOMENDACIONES IMPORTANTES KEY RECOMMENDATIONS

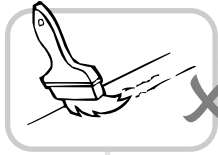

NO pinte el mueble /
Do not paint the
furniture.



NO mojar o ubicar
a la intemperie /
Do not expose to rain
or direct sun.

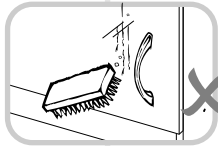
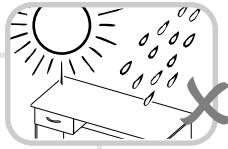

NO lavar las manijas o
tiraderas con jabones o
elementos abrasivos /
Do not wash handles or
drawers with soap or
abrasives.

NO sobrecargue el mueble.
no exceda el peso de 30 kilos
para gabinetes de cocina /
Do not overload the cabinet.
Weight max. 66lbs
for kitchen cabinets.

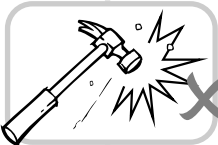

NO golpear ni martillar
el mueble (hágalo sólo
donde se indique) /
Do not hit or hammer
the furniture (just do it
where is indicated).

NO permita que los niños
manipulen el mueble, puede
voltearse y lastimarlos /
Do not allow children to
handle the cabinets or
drawers, they could get hurt.

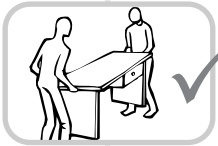
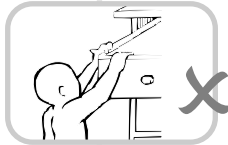

SIEMPRE levante el
mueble entre dos
personas, NO lo arrastre /
Do not drag the furniture.
Lift it between two people.

Limpie con paño seco,
/ Clean with a dry cloth.



HERRAJES BÁSICOS PARA MUEBLES RTA BASIC HARDWARE FOR RTA FURNITURE

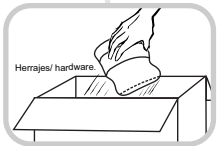

1. Abrir la caja del mueble
y buscar la bolsa con los
herrajes / Open the box
and look for the hardware
bag.

3. Separe los herrajes para
facilitar su identificación
durante el armado /
Separate hardware for easy
identification during
assembly.

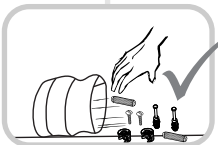
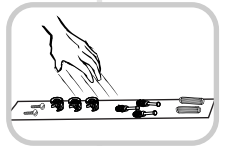

2. Abrir el paquete y
comprobar que el
contenido de las piezas es
correcto / Open the
package and verify that
the content of the pieces
is correct.

4. Arme el mueble en un lugar
limpio y en una superficie
plana / RTA furniture
must be assembled
in a clean place and on
a flat surface.

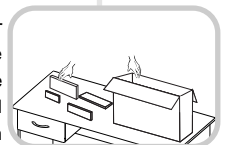

8

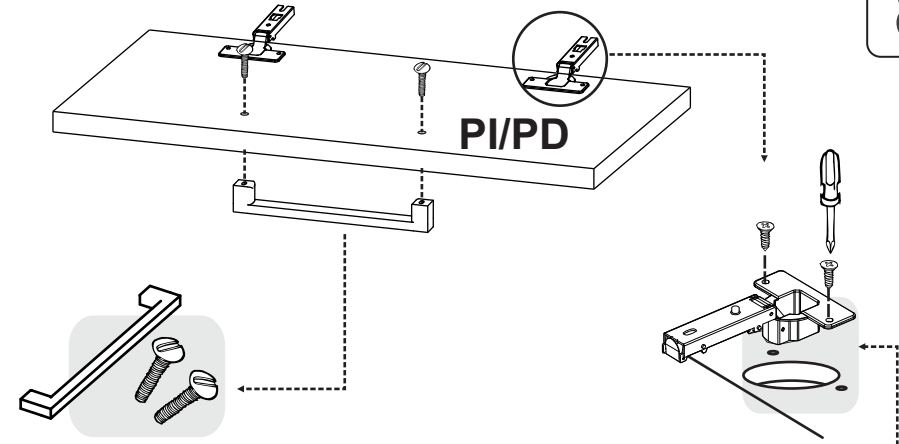

INSTALACIÓN BISAGRAS HINGES INSTALLATION

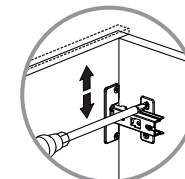
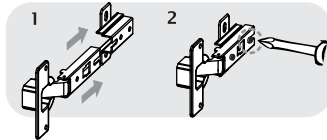

AJUSTE DE ALTURA
/ HEIGHT
ADJUSTMENT

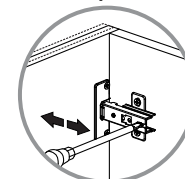

AJUSTE DE
PROFUNDIDAD
/ DEPTH
ADJUSTMENT

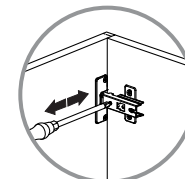

AJUSTE LATERAL
/ LATERAL
ADJUSTMENT

9

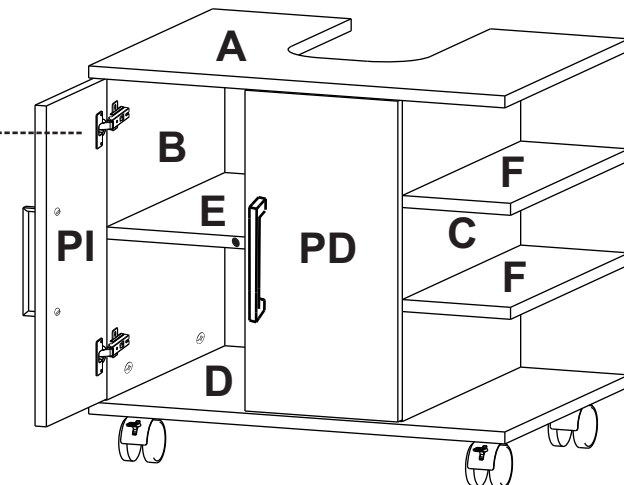

7

Girar 180° /
Rotate 180°

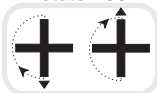

No olvide apretar
todos los Minifix /
Do not forget to
tighten every Minifix.

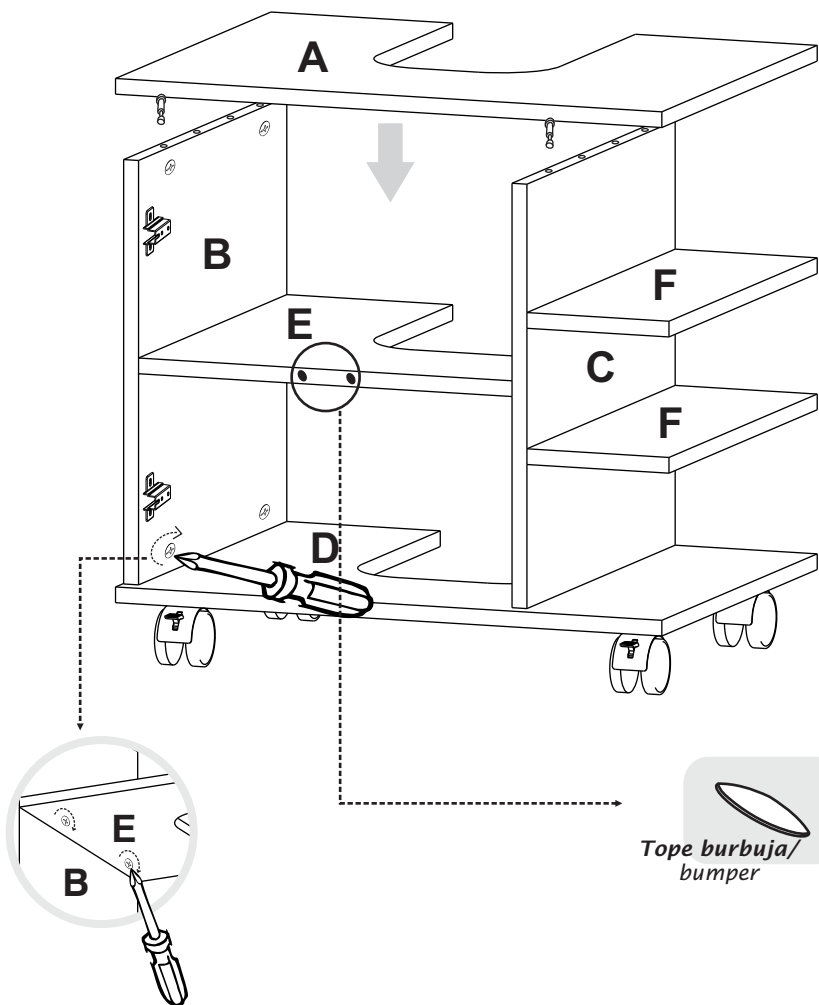

RECOMENDACIONES DE ENSAMBLE / ASSEMBLY RECOMMENDATIONS

El buen funcionamiento del mueble depende de un adecuado ensamblaje
An excellent furniture's performance relies on a solid and a suitable assembly.

MINIFIX / CONNECTOR - DOWELS

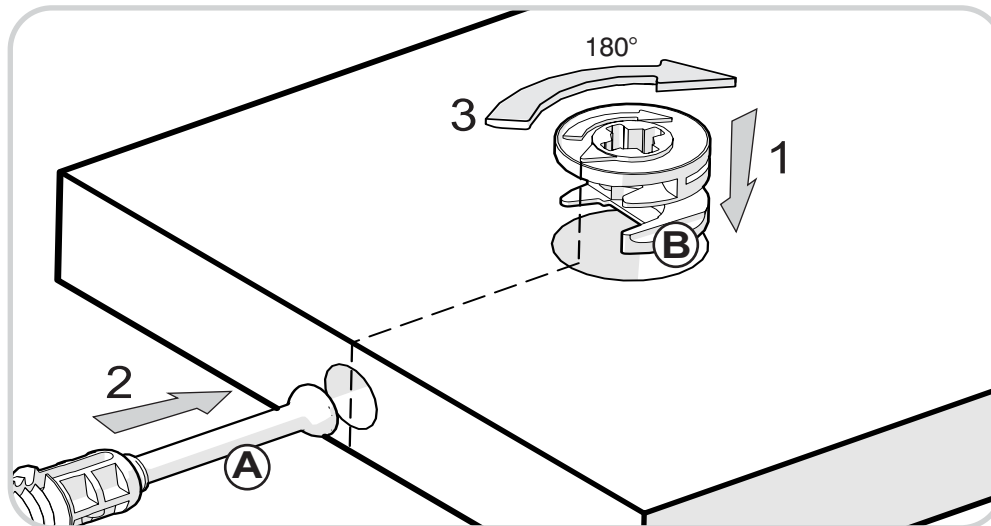

Sistema de unión compuesto por un perno (A) y una caja minifix (B).

(1) Se inserta la caja minifix dentro de la perforación ubicada en la cara de la pieza, la flecha debe apuntar siempre a la dirección de la perforación por donde entrará el perno.

(2) Se debe insertar el perno por su parte plástica en las perforaciones que se indiquen, luego se inserta la punta metálica en la perforación para que su cabeza quede al interior de la caja minifix.

(3) Girar la caja minifix 180° para apretar las dos piezas.

It's a fitting system made of a spreading bolt (A) and a minifix cam (B).

(1) Insert the minifix cam in the hole placed in the face of the panel with the arrow pointing towards the hole where the bolt will fit.

(2) Insert the bolt with its plastic base in the shown holes, then insert the metallic bolt head in the holes so it fits inside the minifix cam.

(3) Tight the panels by turning the minifix cam 180°.

TARUGOS O TAQUETES / FLUTED DOWEL PIN

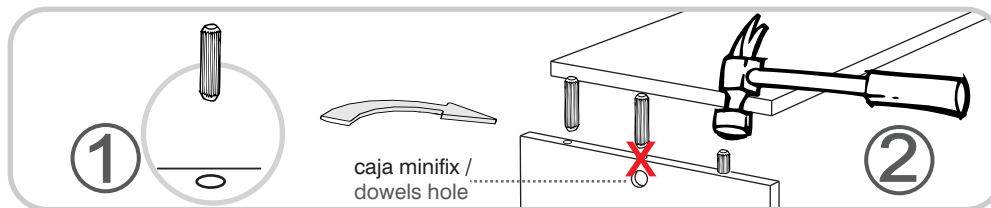

Es un pedazo de madera corto y grueso, de aproximadamente 5 a 10 cm de largo, que sirve para amarrar el mueble y darle resistencia.

It's a short and thick piece of wood, 1,9 to 3,9 inches approximately, which is used to tie the cabinet and give it resistance.

HERRAJES PARA ARMADO ASSEMBLE HARDWARE

x14



Minifix/
Minifix Cams

x14

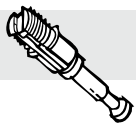

Perno minifix/
Spreading Bolt

x16



Tarugo/
Wooden Pin

x32



Tornillo lámina
6 X 9/16"/
Sheet Screw

x14



Tapa Adhesiva
Minifix/
Cover Caps

x4



Tornillo Manija/
Handle Screw

x4

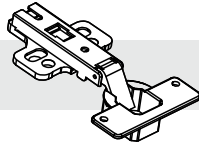

Bisagra Parche/
Full Overlay Hinge

x2



Tope Burbuja/
Bumper

x2

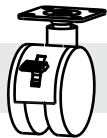

Rodachina 50mm
con Freno/
Wheel Caster with
brake

x2



Rodachina 50mm/
Wheel Caster

x2

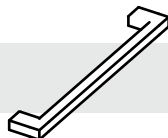

Manija 128cc/
Handle



IMPORTANTE

TENER PRECAUCIÓN AL ABRIR LA BOLSA DE HERRAJES PARA NO EXTRAVIAR NINGUNO. COMPRUEBE QUE EL CONTENIDO DE LAS PIEZAS SEA EL CORRECTO. EN CASO QUE FALTE ALGUNA PIEZA O ESTE DEFECTUOSA DEVUELVA LAS PIEZAS AL ALMACÉN CON SU FACTURA PARA EFECTUAR EL CAMBIO DE LAS PIEZAS Y/O LOS HERRAJES LO MÁS PRONTO POSIBLE. / PLEASE BE CAUTIOUS WHEN OPENING THE HARDWARE BAG TO NOT LOSE ANY. CHECK THE CONTENTS OF THE PARTS ARE CORRECT. IF ANY PART IS MISSING OR DEFECTIVE PLEASE RETURN THE PARTS TO THE STORE WITH THE PRODUCT INVOICE ATTACHED TO MAKE EFFECTIVE THE REPLACEMENT OF THE DEFECTIVE PIECES OR WARDWARE AS SOON AS POSSIBLE.

5

Tenga en cuenta: Ensamble primero la pieza F(1) al mueble y aprete los Minifix, luego ensamble la pieza F(2) y aprete los Minifix. Los Minifix de las 2 piezas, deben quedar ocultos (por debajo del mueble). /

Note: First, assemble part F (1) to the structure and tighten the Minifix, second assemble part F (2) and tighten the Minifix. Finally, All Minifix must be hidden (under cabinet).



IMPORTANTE

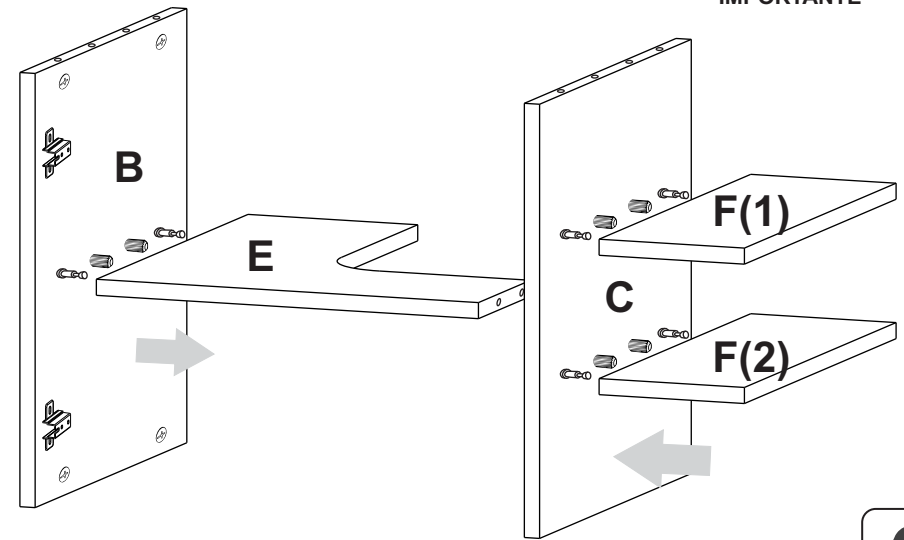

6

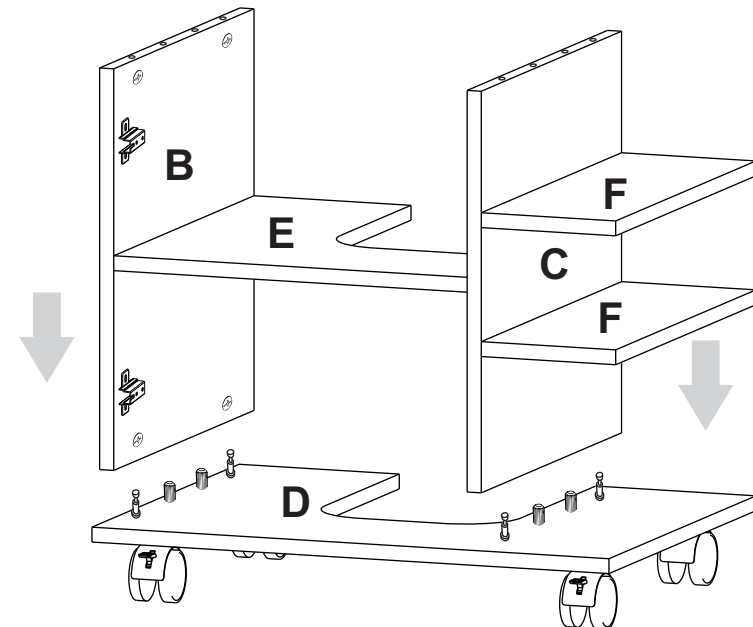

3



SE RECOMIENDA ARMAR EL MUEBLE ENTRE DOS PERSONAS / IT IS RECOMMENDED TO ASSEMBLE THE PRODUCT BETWEEN TWO PEOPLE

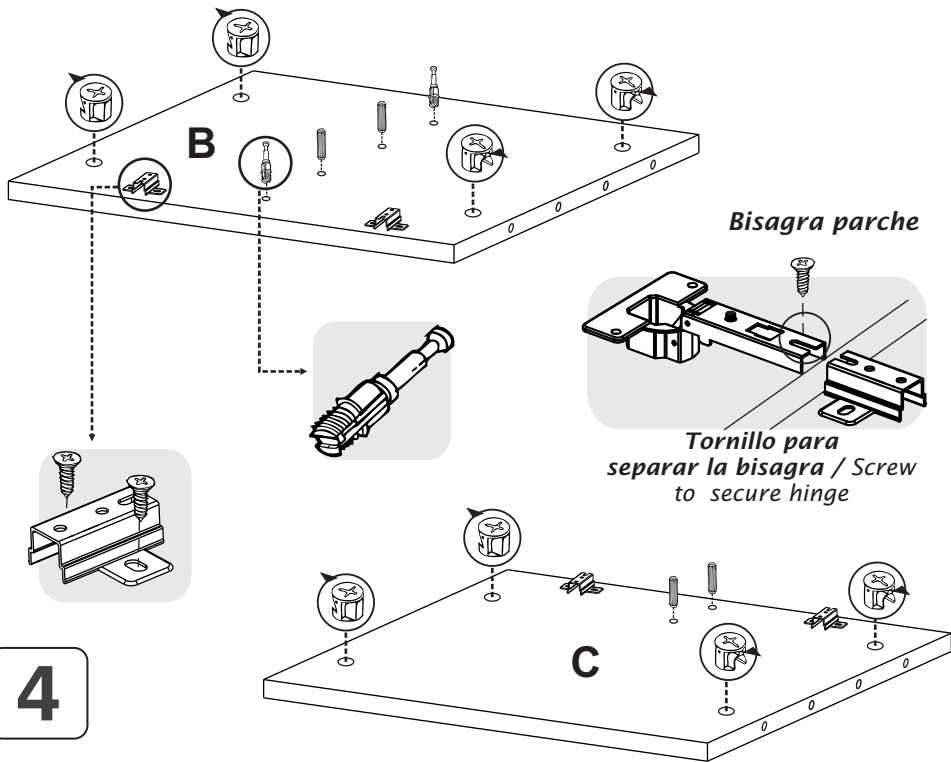

4

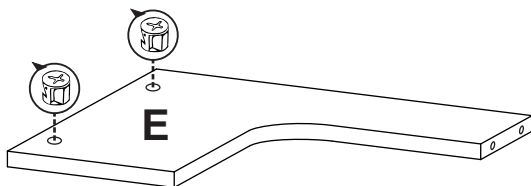
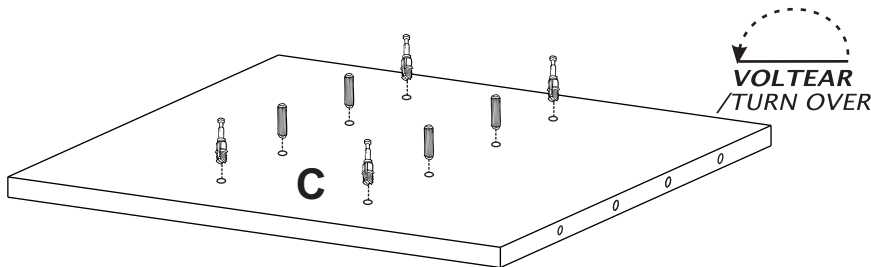

PIEZAS DE ARMADO ASSEMBLY PARTS

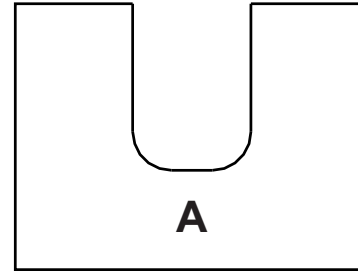

A

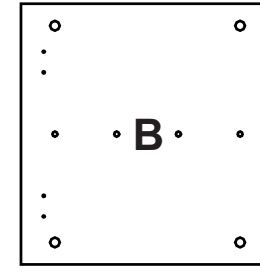

B

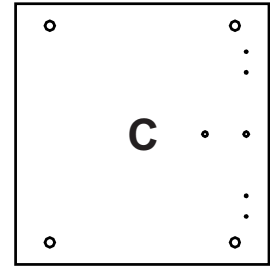

C

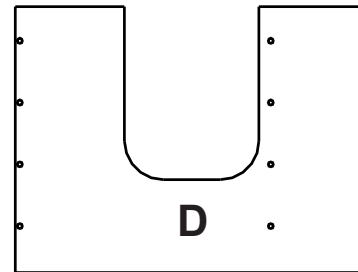

D

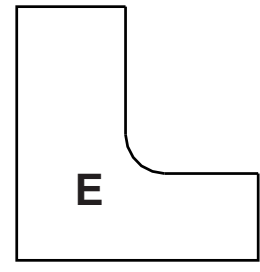

E



Fx2

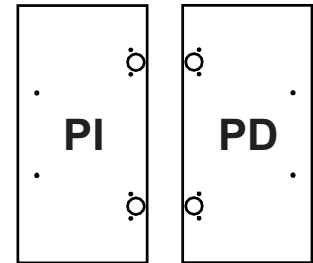

PI

PD



IMPORTANTE

ANTES DE EMPEZAR A ARMAR EL MUEBLE LEA DETENIDAMENTE LAS INSTRUCCIONES. SE RECOMIENDA ARMAR EL MUEBLE SOBRE LA CAJA O SOBRE UNA SUPERFICIE LISA Y CUBIERTA, PARA NO RAYARLO / BEFORE STARTING TO ASSEMBLE THE FURNITURE, CAREFULLY READ THE INSTRUCTIONS. IT IS RECOMMENDED TO ASSEMBLE THE FURNITURE ON THE BOX OR ON A FLAT AND COVERED SURFACE IN ORDER TO NOT SCRATCH THE PRODUCT.

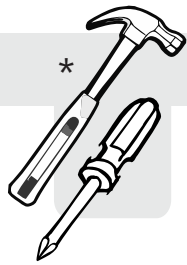

* (Herramientas NO incluidas)

*Tools NOT Included

•Martillo/ Hammer

•Destornillador de Estrella/
Crosshead Screwdriver

