

1
Ajuste de las bisagras
Hinge adjustment

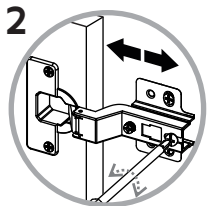

2
Ajuste de Profundidad
Depth adjustment

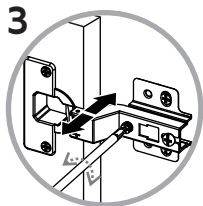

3
Ajuste lateral
side adjustment

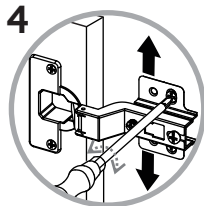

4
Ajuste de altura
Height adjustment

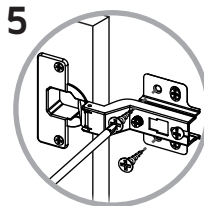

5

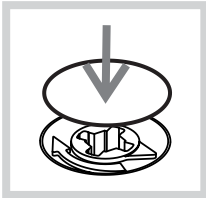

Después de ajustar todas las cajas minifix, cúbralas con las tapas adhesivas.
After you finish the adjustment of the cams, cover them with the cover caps.

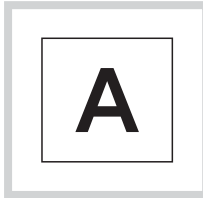

Al terminar de armar, desprenda las letras adhesivas.
After you finish assembling the cabinet, take off the adhesive letters.



INSTRUCCIONES DE ENSAMBLE
ASSEMBLY INSTRUCTIONS

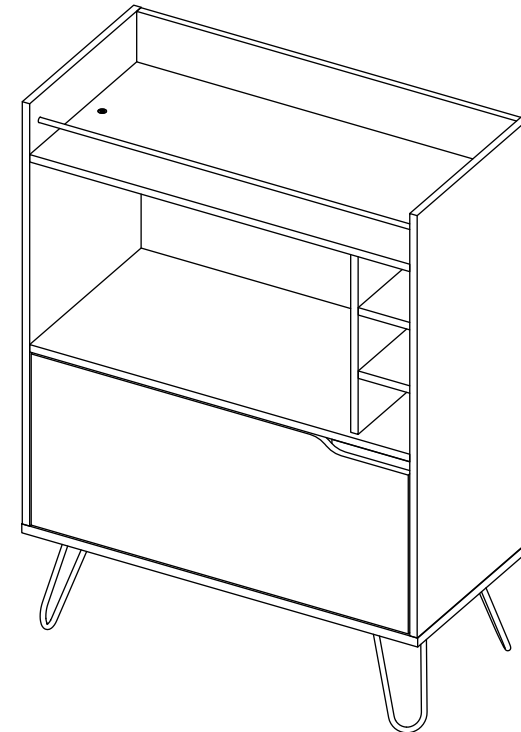

Alto: 107,1 cm
Ancho: 80 cm
Fondo: 39 cm

Height: 42,19 in
Width: 31,50 in
Depth: 15,35 in

LOT N°

REF./SKU. BDX 6311

BAR BAJO MONACO
MONACO LOW BAR

RECOMENDACIONES IMPORTANTES

No pintar el mueble.

El mueble debe ser usado únicamente en interiores, no exponer al sol directo.

Limpiar los herrajes metálicos con un paño seco.

NO sobrecargar el mueble (ver las cargas sugeridas).

No golpear ni martillar el mueble (solo cuando se indique).

Limpiar con un paño ligeramente húmedo, usar jabones suaves.

No arrastre el mueble, levántelo entre dos personas.

Evite el contacto directo con el agua, el fuego o la exposición a fuentes de calor.



ADVERTENCIA

Nunca permita que los niños escalen o manipulen el mueble, la caída de este puede provocar lesiones graves o la muerte.

IMPORTANT RECOMMENDATIONS

Do not paint the cabinet.

The cabinet **MUST** be used exclusively indoors, do not expose to direct sun.

Clean metallic hardware with a dry cloth.

Do **NOT** overload the cabinet (see suggested loads).

Do not hit or hammer the cabinet (just when indicated).

Clean with a slightly damp cloth, use gentle soaps.

Do not drag, lift and move between two people.

Avoid direct contact with water, fire or exposure to heat sources.



WARNING

Never allow children to climb or manipulate the cabinet, furniture tip over can cause serious injuries or death.

VOLTEAR EL MUEBLE CUIDADOSAMENTE
/ CAREFULLY FLIP THE FURNITURE



25

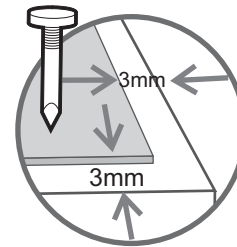
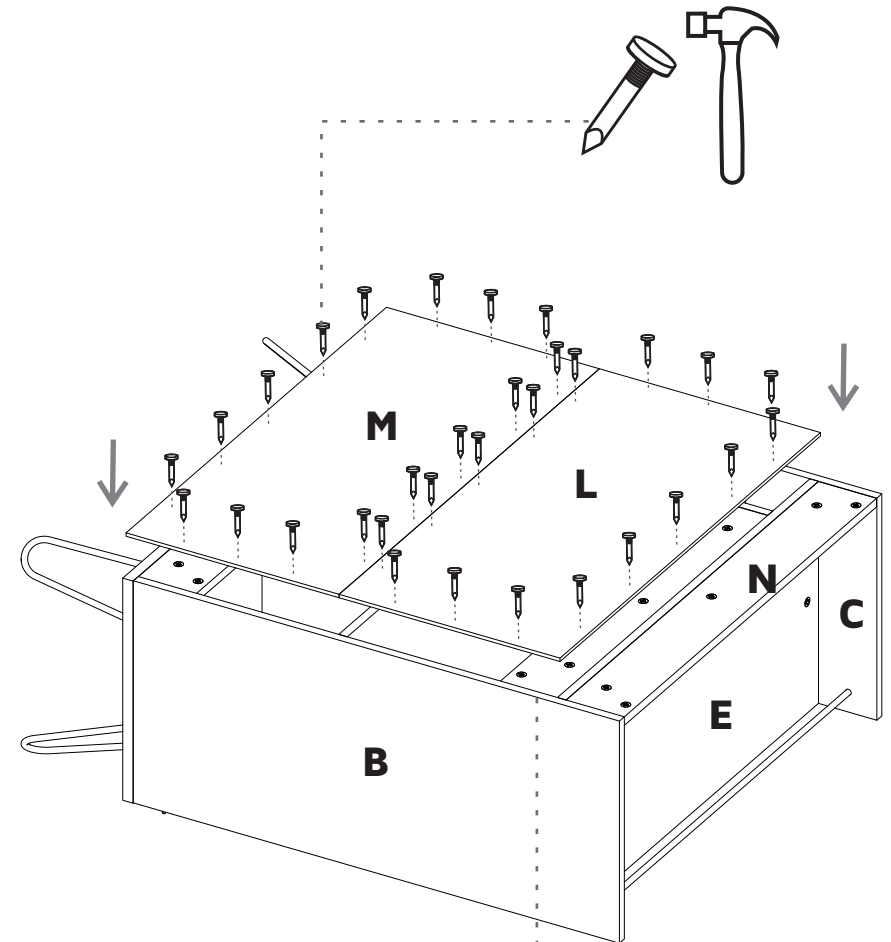

23

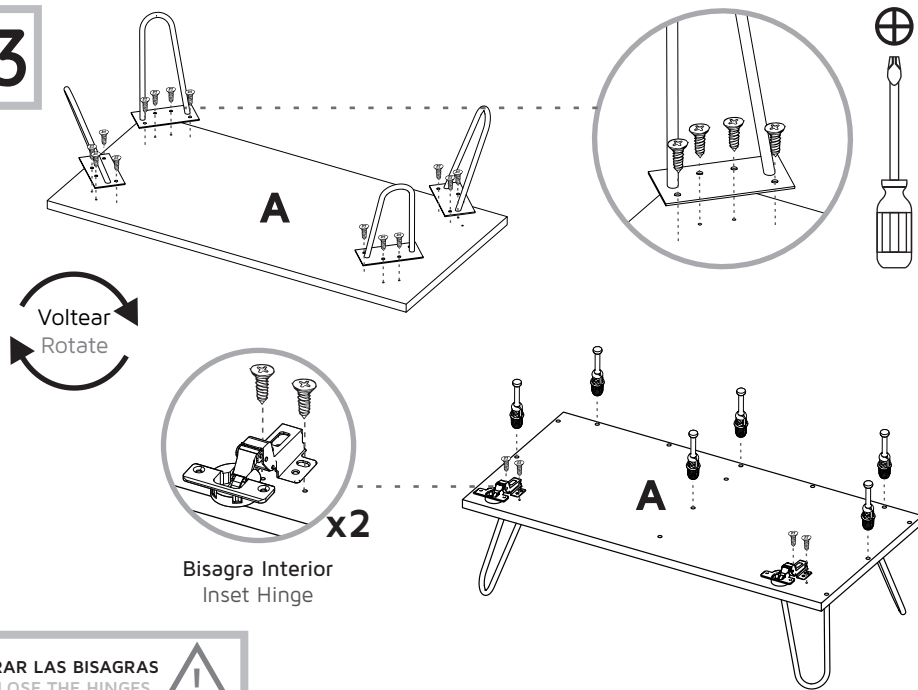

CERRAR LAS BISAGRAS
/ CLOSE THE HINGES



Bisagra Interior
Inset Hinge

24

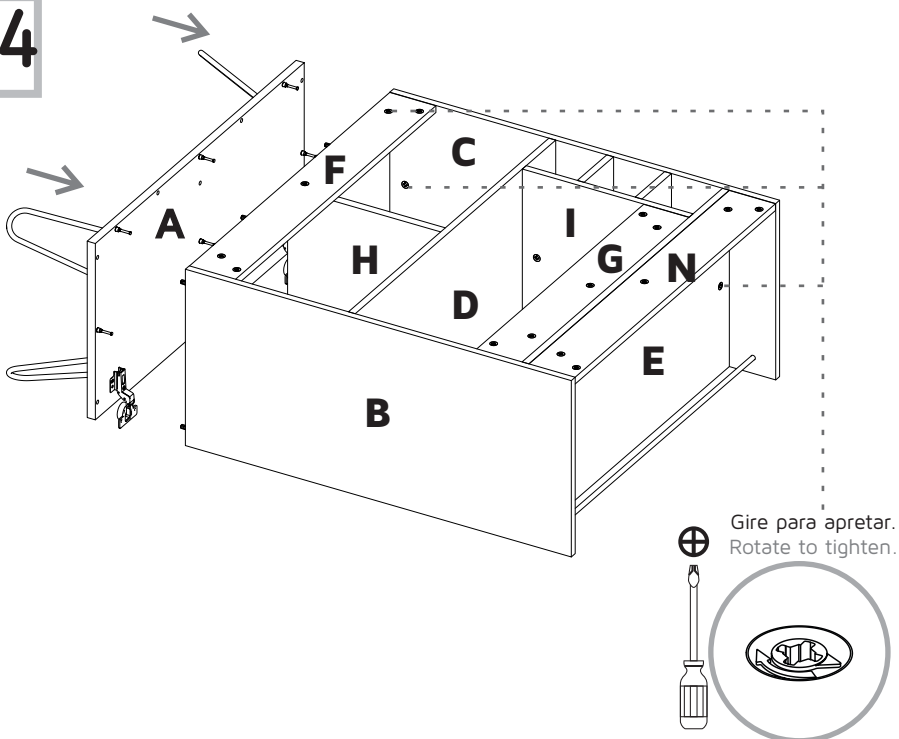

Gire para apretar.
Rotate to tighten.

ÍNDICE INDEX

Herrajes para armado Assembly Hardware	4
Piezas de armado Assembly Parts	5
Cargas sugeridas Suggested loads	6
Recomendaciones de ensamble Assembly recommendations	6
Pasos de armado Assembly steps	7-20

HERRAMIENTAS NECESARIAS* REQUIRED TOOLS*

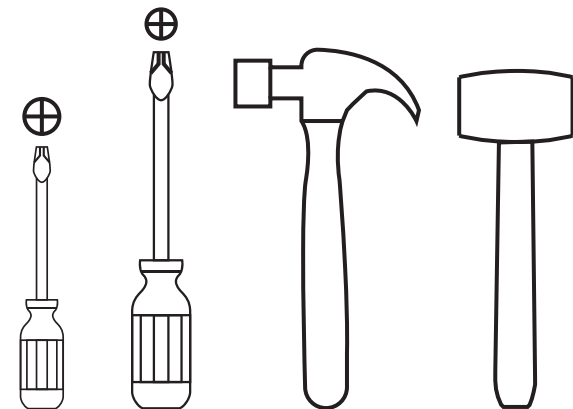

*No incluidas y no se muestran en tamaño real.
*Not included, and not shown actual size.

HERRAJES PARA ARMADO ASSEMBLY HARDWARE

Compruebe que el contenido de los herrajes sea el correcto. En caso de que falte alguna pieza, por favor llame a nuestra línea de atención al cliente.

Please check that the hardware content is correct. If any item is missing, please call to our customer service line.



x45

Tarugo
Wood Dowel



x26

Minifix
Minifix Cams



x26

Perno Minifix
Spreading Bolt



x30

Tapa Adhesiva
Minifix
Cover Caps



x16

Tornillo Lámina
Flat Head Screw

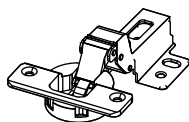

x2

Bisagra Interior
(Incluye tornillos)
Inset Hinge
(Screws Included)

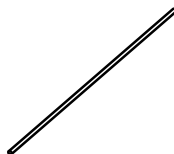

x1

Tubo.
Tube.

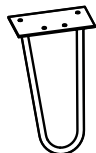

x4

Pata
Steel Leg



x32

Puntillas
Nails

21

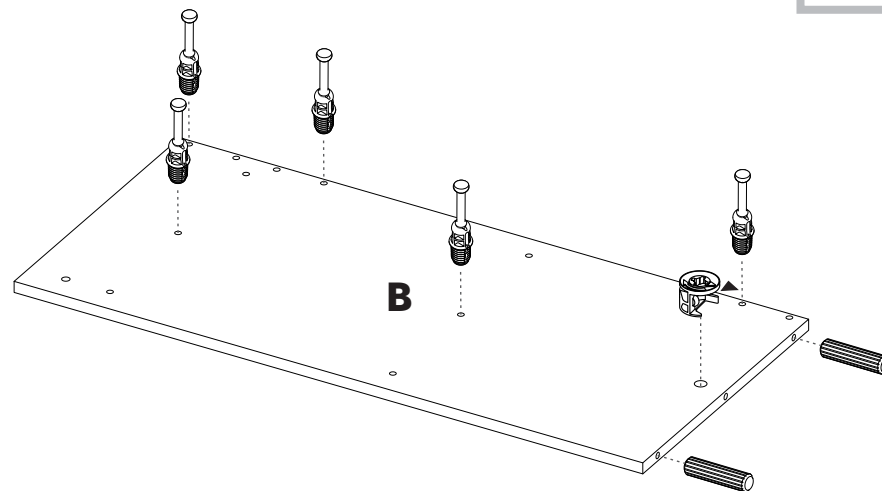

22

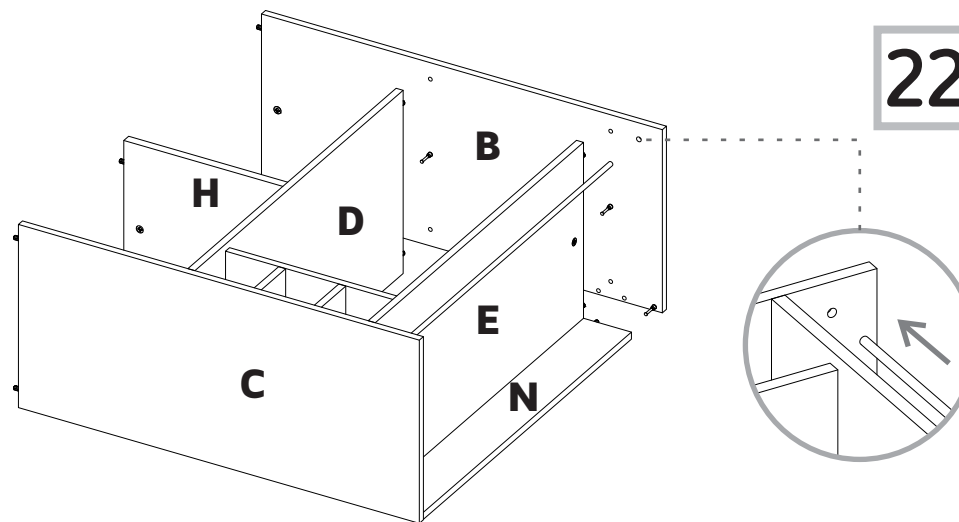

19

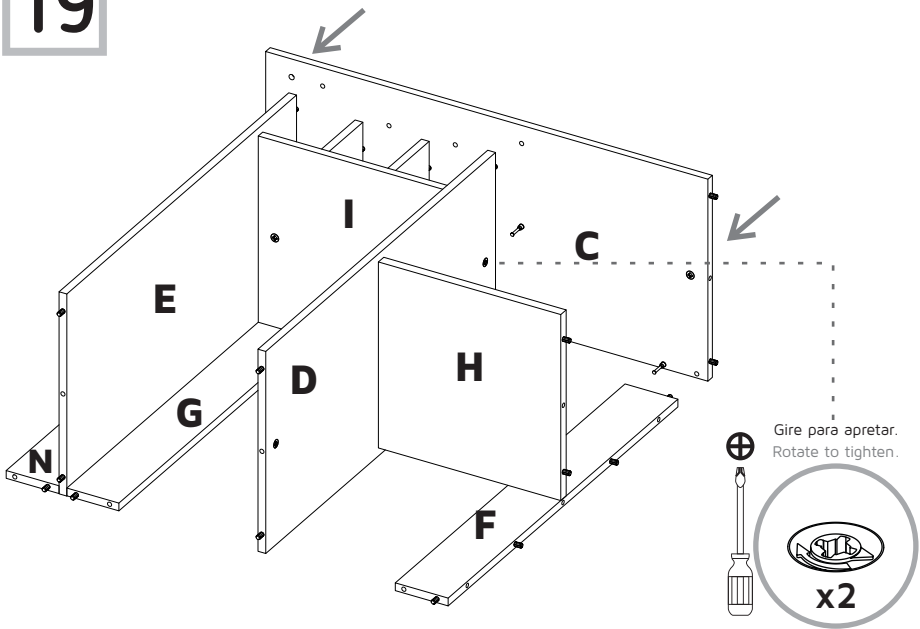

20

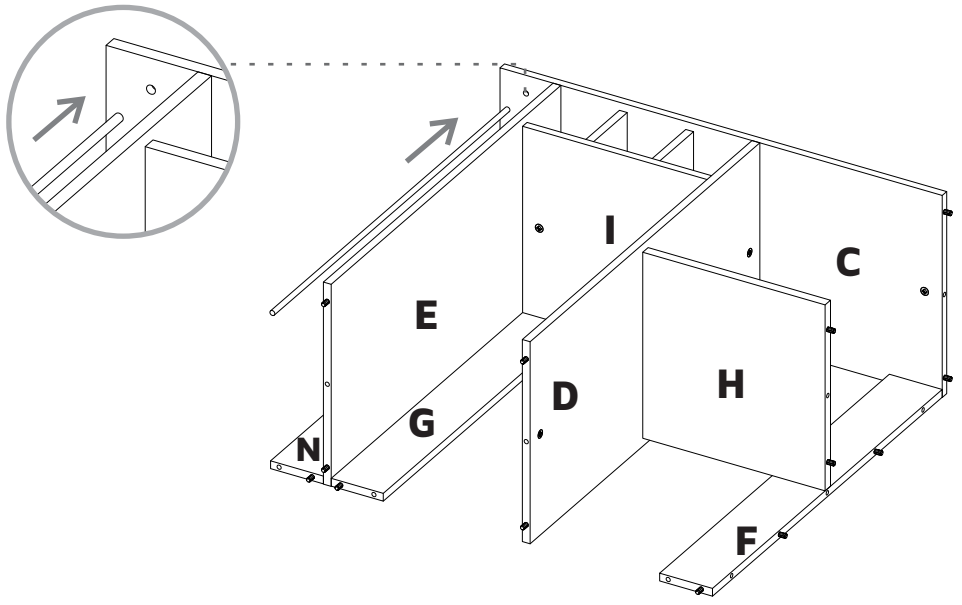

PIEZAS DE ARMADO
ASSEMBLY PARTS

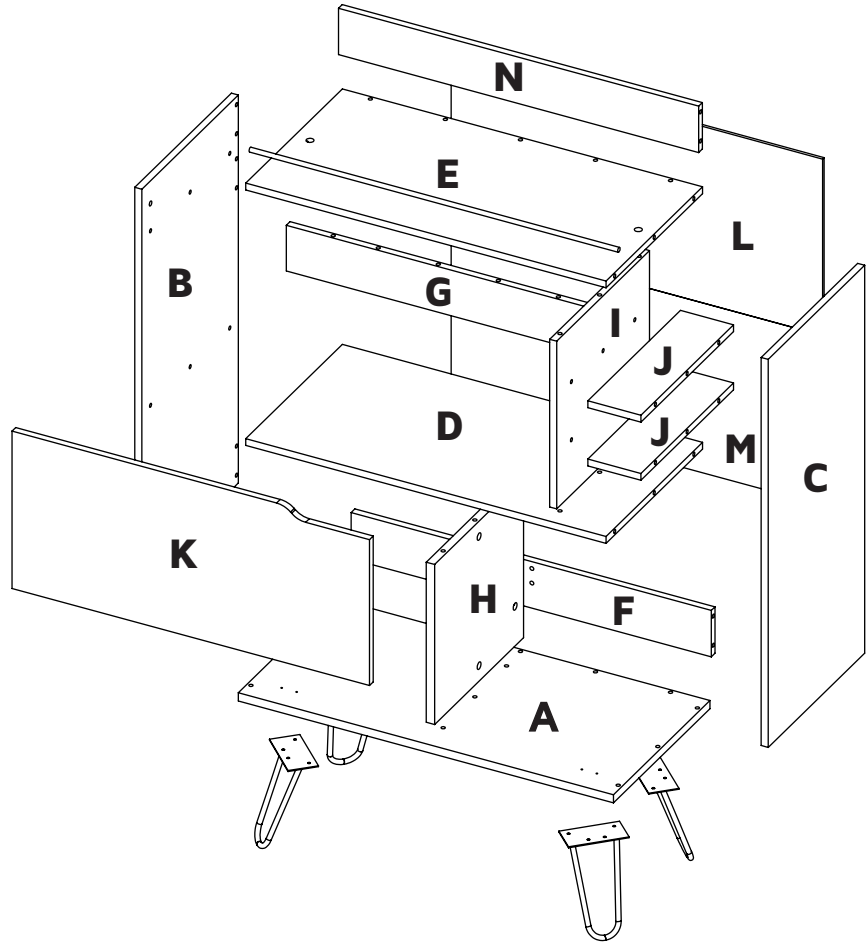

- | | | | |
|--------|--------|--------|--------|
| A - x1 | E - x1 | I - x1 | M - x1 |
| B - x1 | F - x1 | J - x2 | N - x1 |
| C - x1 | G - x1 | K - x1 | |
| D - x1 | H - x1 | L - x1 | |

MAX SUGGESTED LOADS CARGAS MÁXIMAS SUGERIDAS

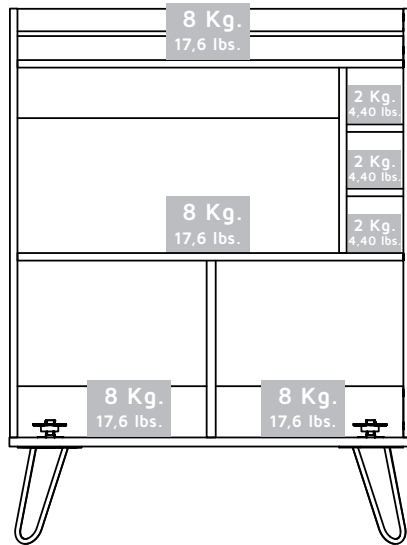

ASSEMBLY RECOMMENDATIONS RECOMENDACIONES DE ENSAMBLE

Ensamble el mueble entre dos personas.

Assemble the cabinet between two people.

Ensamble el mueble sobre una superficie plana y lisa, preferiblemente sobre un tapete o el cartón de la caja

Assemble the cabinet on a flat, smooth surface, preferably on a carpeted floor or the box carton.

Lea cuidadosamente las instrucciones e identifique todas las piezas y herrajes antes de empezar a armar el mueble.

Carefully read all the steps and identify all the wood parts and hardware before assembling the cabinet.

17

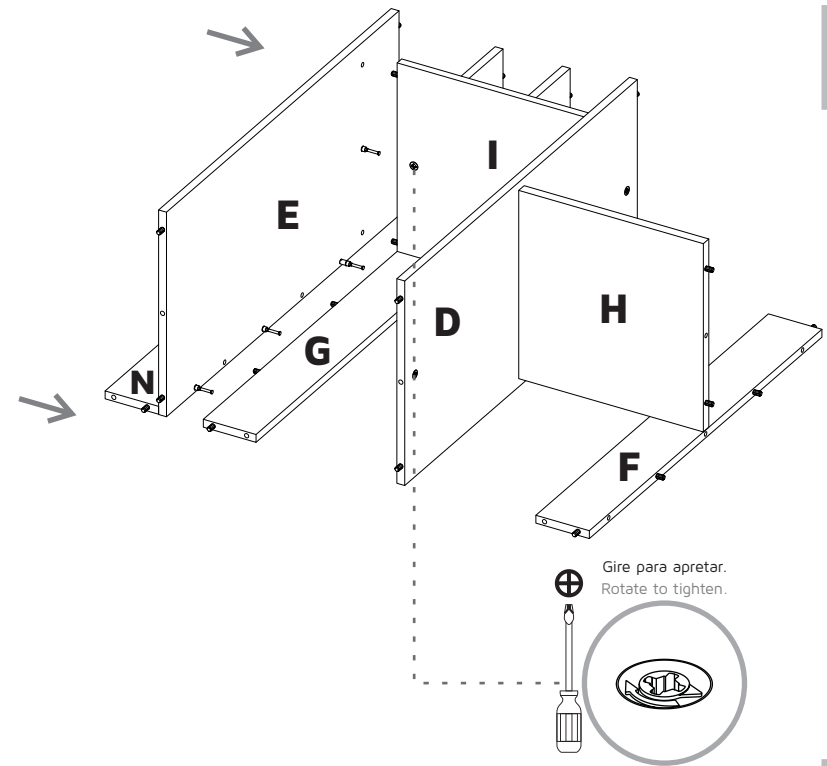

18

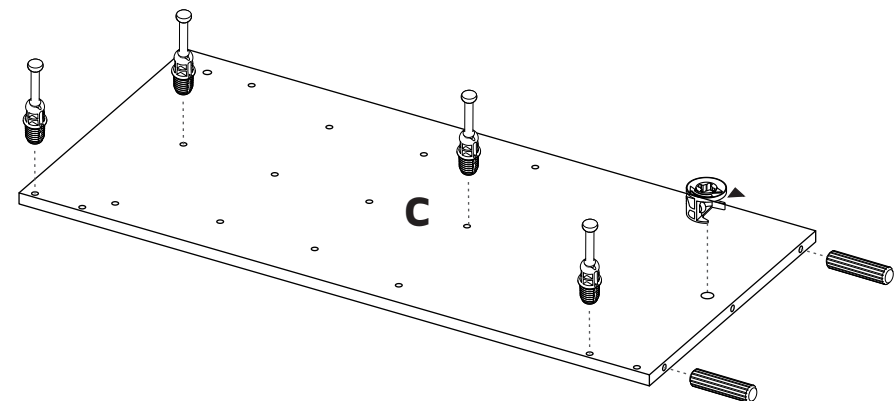

15

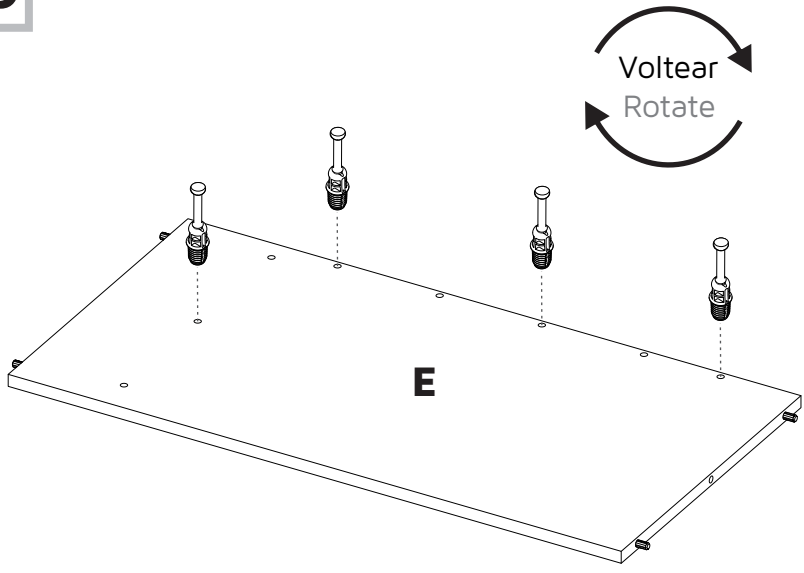

16

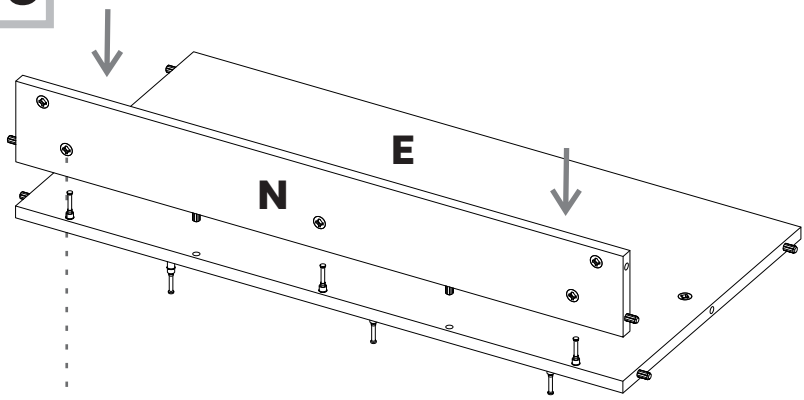

Gire para apretar.
Rotate to tighten.



1

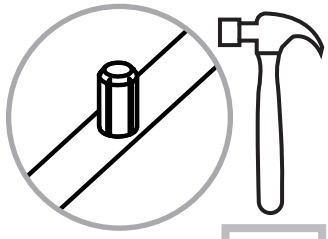
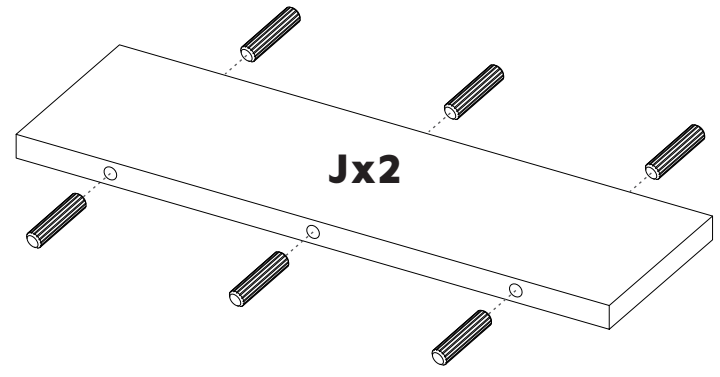

2

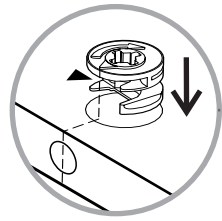

NO apriete las cajas
minifix en este paso.
Do NOT tighten the
cams in this step.

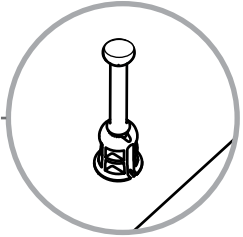
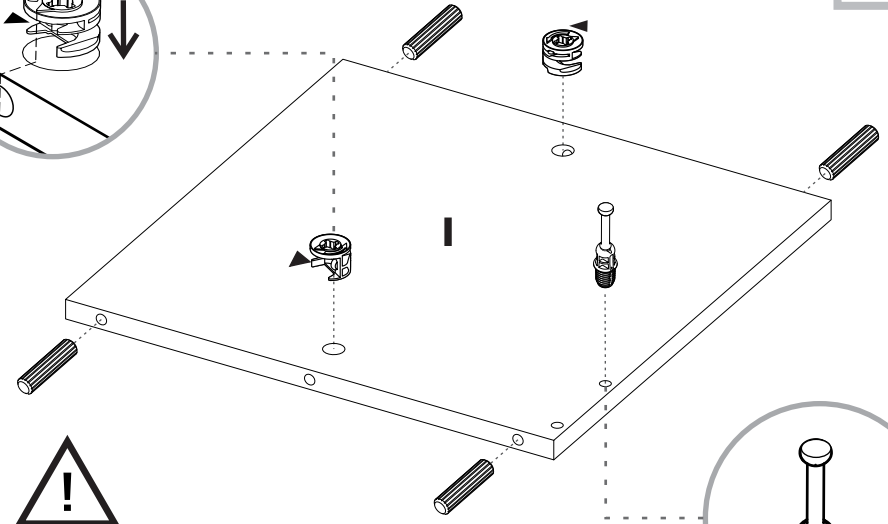

3

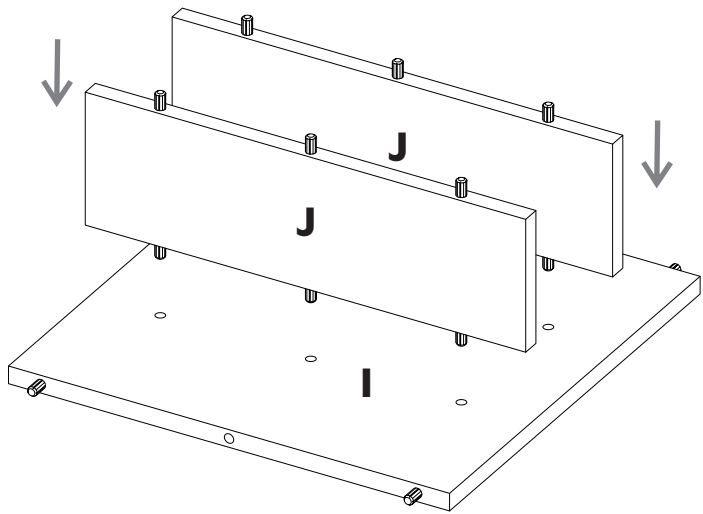

4

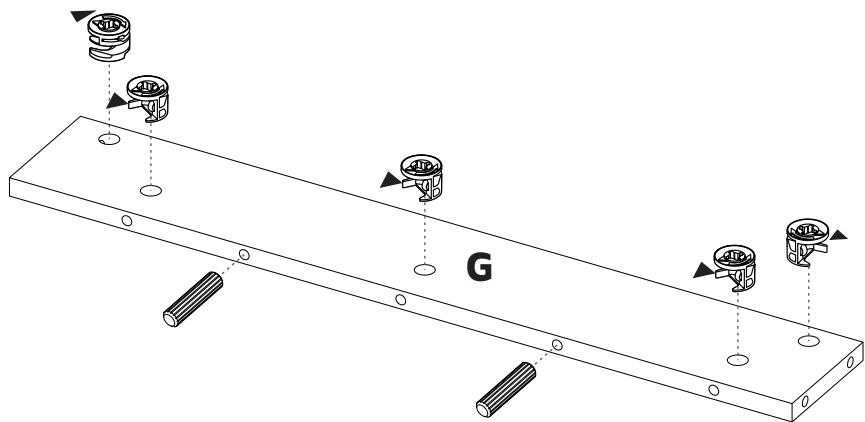

13

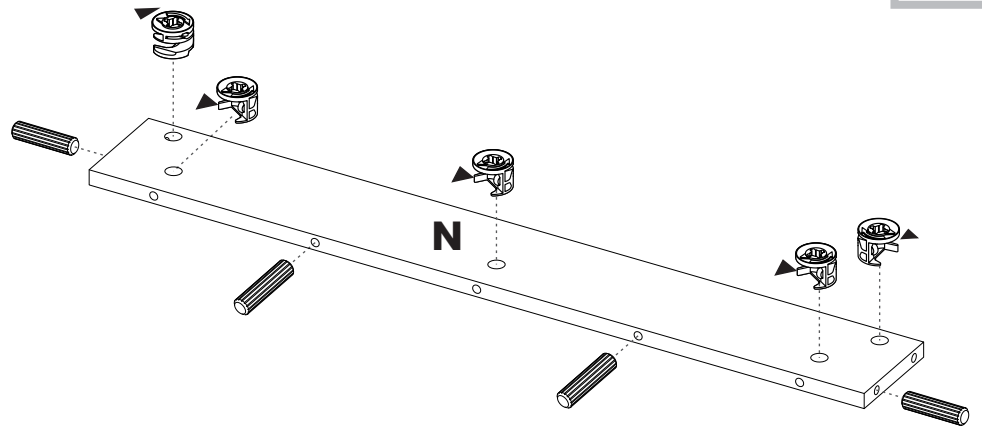

14

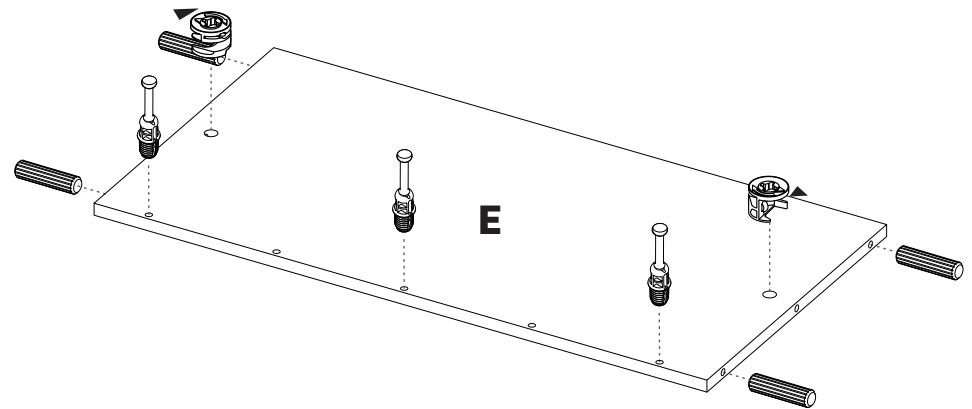

11

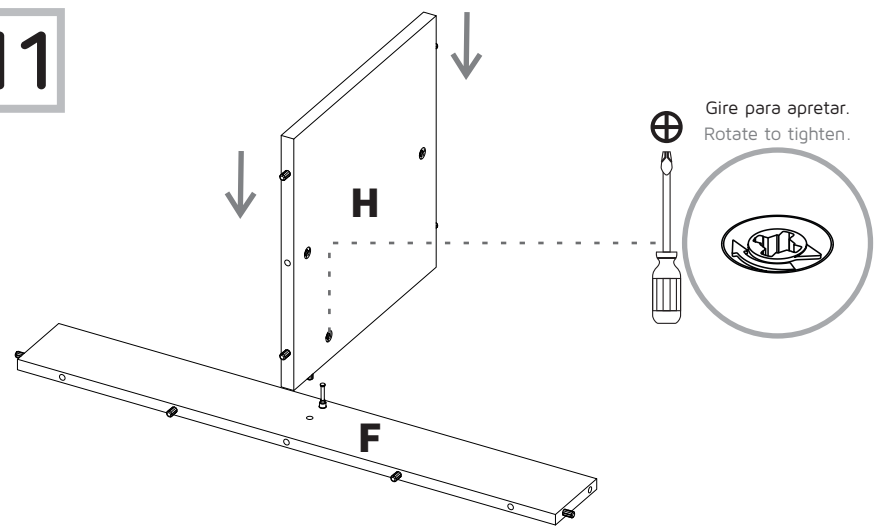

5

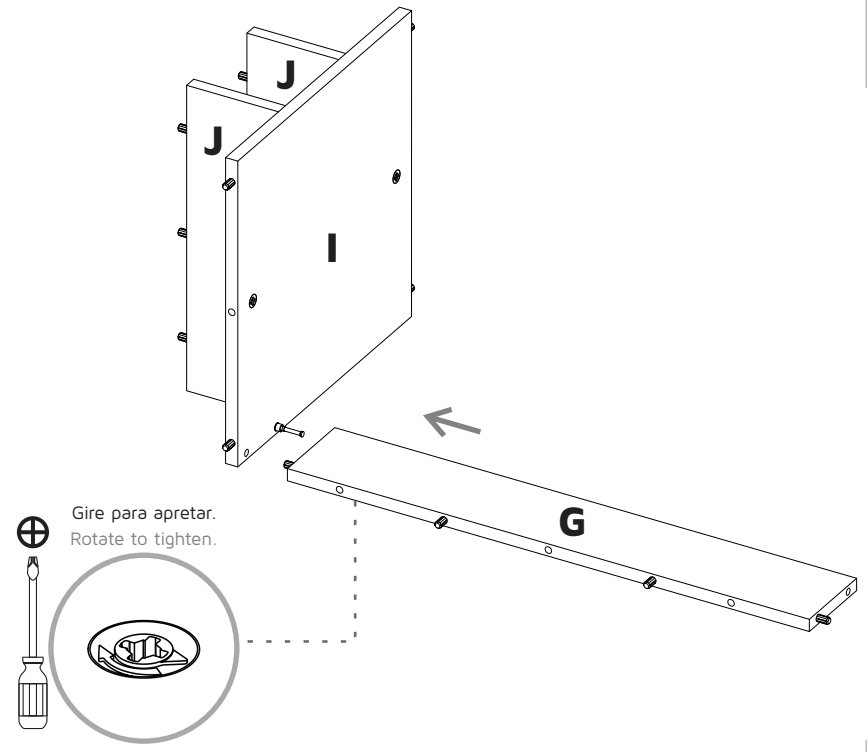

12

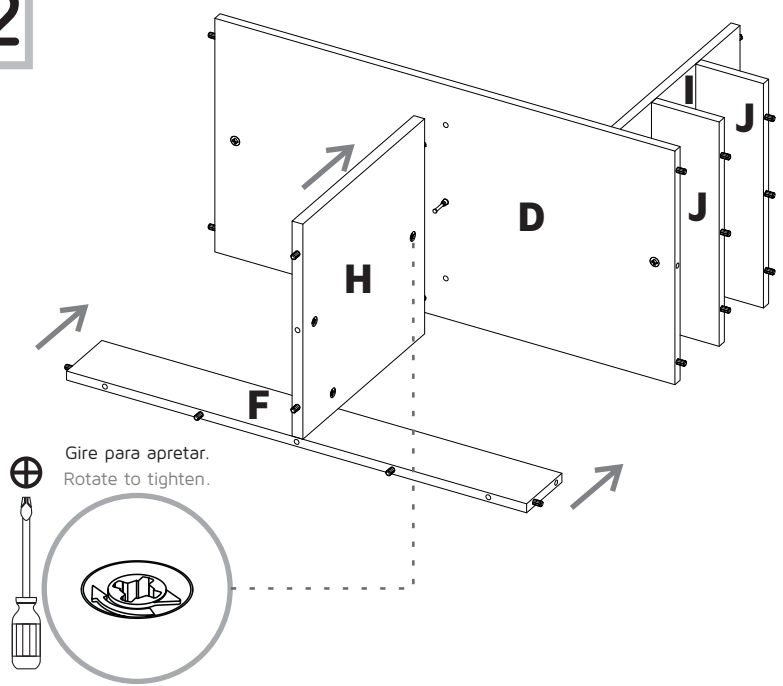

6

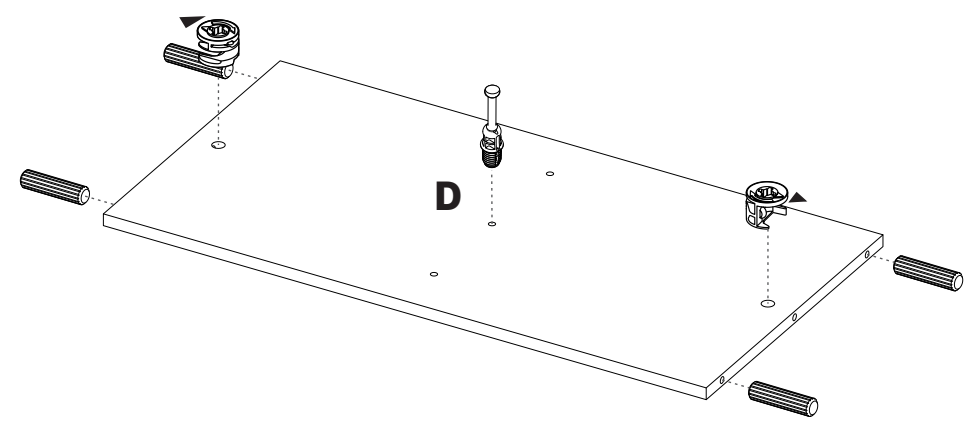

7

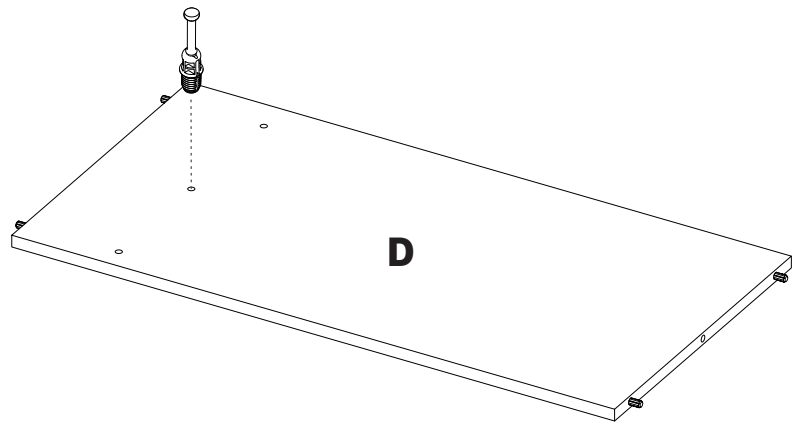
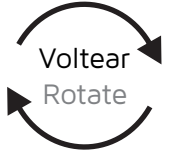

8

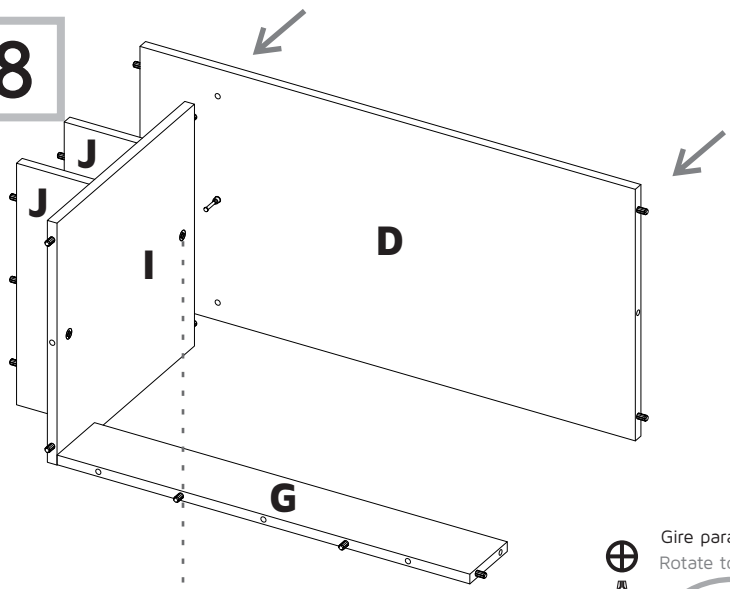

9

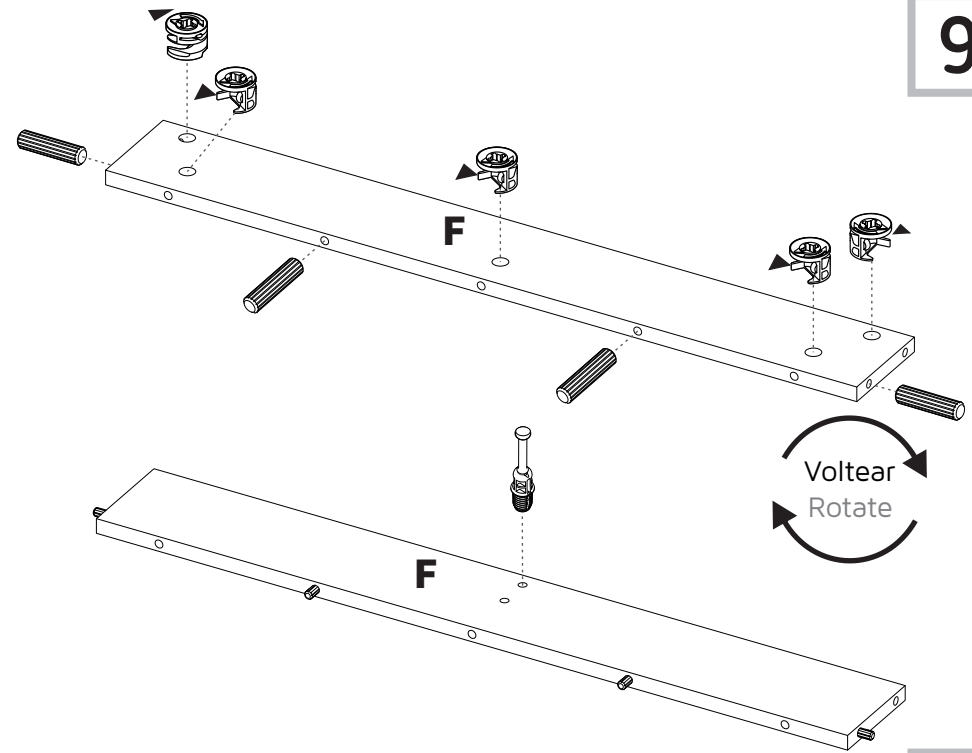

10

