

# ARMARIO ALTO DE COCINA Z60 - 2P

Z60 - 2P Kitchen Tall

Barmoire Haute de Cuisine

Armoire

Z60 - 2P

REF. ALB 7400



60min

## INSTRUCCIONES DE ARMADO

### ASSEMBLY INSTRUCTION

### INSTRUCTIONS DE MONTAGE

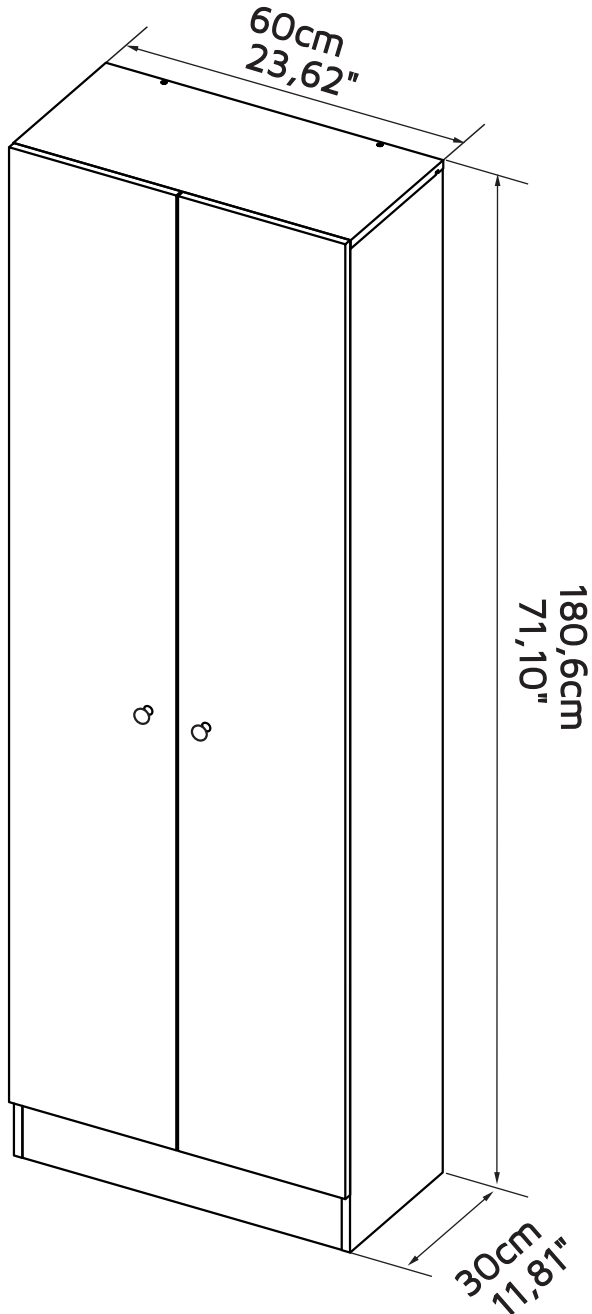

#### WARNING

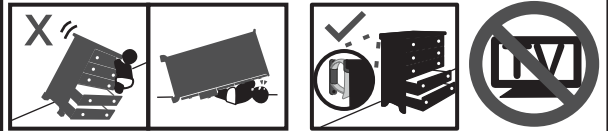

Niños han fallecido debido a volcamientos de muebles. Para reducir el riesgo de volcamiento:

- SIEMPRE asegure este mueble a la pared utilizando un dispositivo antivuelco
- NUNCA permita que los niños se paren, suban o se cuelguen de los cajones, puertas o estantes.
- No desactive ni retire el sistema de bloqueo de cajones.
- Coloque los objetos más pesados en los cajones inferiores
- NUNCA coloque un televisor en este mueble.

Children have died from furniture tip over. To reduce the risk of tip over:

- ALWAYS secure this furniture to the wall using an anti-tip device.
- NEVER allow children to stand, climb, or hang on drawers, doors or shelves.
- Do not defeat or remove the drawer interlock system.
- Place heaviest items in the lowest drawers.
- NEVER put a TV on this furniture.

Les enfants sont morts à cause de basculements de meubles. Pour réduire le risque de basculement :

- ATTACHEZ TOUJOURS ce meuble au mur en utilisant un dispositif anti-basculement.
- N'autorisez JAMAIS les enfants à se tenir debout, à grimper ou à s'accrocher aux tiroirs, aux portes ou aux étagères
- Ne désactivez pas ou ne retirez pas le système de verrouillage des tiroirs..
- Placez les objets les plus lourds dans les tiroirs les plus bas.
- NE placez JAMAIS de télévision sur ce meuble.

Para garantizar la seguridad de quienes usan este mueble, es crucial asegurarlo correctamente a la pared utilizando un dispositivo antivuelco.

Este producto incluye los elementos necesarios para fijar el mueble a la pared.

Sin embargo, es importante tener en cuenta que una instalación incorrecta o no utilizar el dispositivo antivuelco puede provocar lesiones graves e incluso la muerte. Por esta razón, recomendamos encarecidamente

que un instalador profesional se encargue de la instalación del armario en la pared. To ensure the safety of those using this cabinet, it is crucial to properly secure it to the wall using a tip-over device. This product includes the necessary items for fixing the furniture to the wall. However, it is important to note that incorrect installation or failure to use the tip-over device can result in serious injury or even death.

For this reason, we highly recommend that a professional installer handle the installation of the cabinet to the wall.

Pour garantir la sécurité de ceux qui utilisent cette armoire, il est crucial de la fixer correctement au mur à l'aide d'un dispositif de prévention des basculements.

Ce produit comprend les éléments nécessaires pour fixer le meuble au mur.

Cependant, il est important de noter qu'une installation incorrecte ou le non-usage du dispositif de prévention des basculements peut entraîner des blessures graves, voire la mort.

Pour cette raison, nous recommandons vivement qu'un installateur professionnel se charge de l'installation de l'armoire au mur.

LOT N°

## ¿Por dónde empezamos?

### ¡Esto es muy IMPORTANTE

En las próximas páginas está el contenido de las piezas y herrajes del mueble.

Asegúrate de que la cantidad de herrajes y piezas que hay en la caja sea la correcta y todo esté en buen estado.

(Ya que cuando el mueble esté armado no podrás realizar ninguna reposición)

## Where should you start?

### This is so IMPORTANT

Over the next few pages is the panel and hardware content for this cabinet.

Please make sure that the quantity of each one is correct, and that everything is in good shape.

(When the cabinet is already assembled there's no warranty for this)

## Par où commencer?

### Ceci est très IMPORTANT

Dans les pages suivantes se trouve le contenu des pièces et garnitures du meuble.

Vérifier que la quantité de pièces et de garnitures présents dans la boîte est correcte et que tout est en bon état.

(Lorsque l'armoire sera assemblée, aucun pièce ne pourra être remplacée)

## Qué vamos a necesitar?

Destornillador de estrella.



Destornillador de pala.

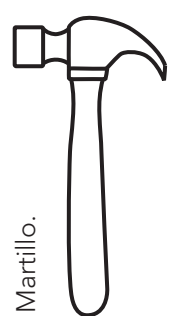

Martillo.

Una superficie plana y lisa, puedes utilizar el cartón de la caja del mueble o sobre un tapete.

Un destornillador eléctrico no es necesario, pero podría facilitarte el trabajo.

## What will you need?

Phillips head screwdriver



Flat head screwdriver

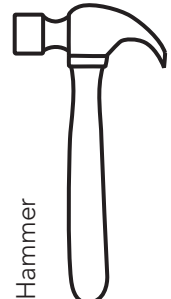

Hammer

A flat, smooth surface. You can use the cardboard of the box or a rug.  
An electric screwdriver isn't necessary, but it can make the work much easier.

## De quoi aurons-nous besoin?

Tournevis cruciforme.



Tournevis à tête plate.

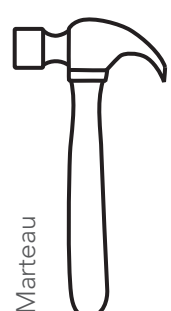

Marteau

Une surface plane et lisse. Vous pouvez utiliser le carton de la boîte ou un tapis.  
Un tournevis électrique n'est pas nécessaire, mais il peut rendre le travail beaucoup plus facile.

# HERRAJES DE ARMADO

## Assembly Hardware

## Matériel D'assemblage

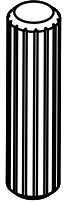

**x37**

Tarugo  
Wood Dowel/  
Cheville en bois.



**x16**

Perno Minifix  
Spreading Bolt/  
Boulon d'écartement



**x16**

Minifix  
Minifix Cams/  
Cames Minifix



Color 1

**x20**

Tapa Adhesiva  
Minifix  
Cover Caps/  
Plaques de  
couverture/Cache

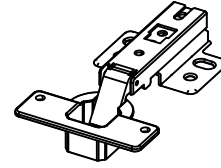

**x6**

Bisagra + Tornillos  
Hinge + screws/  
Charnière +des vis

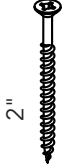

**x2**

Tornillo ensamble  
Drywall Srew/  
Vis à cloison sèche

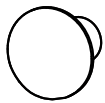

**x2**

Boton  
Knob /  
Bouton



**x4**

Tornillo lámina  
Flat head screw/  
Tête plate vis

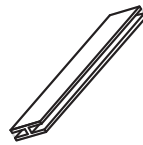

**x1**

Perfil H  
H profile/  
Profil H

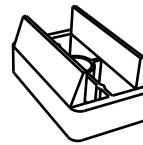

**x4**

Deslizador en U  
U Slipper/  
U pantoufle



**x2**

Kit Antivuelco  
(Tornillos incluidos)  
Wall Fixing Kit  
(Screws Included) /  
Kit de Fixation Murale  
(Vis incluses)

## PIEZAS DE ARMADO

### Assembly Parts

### Pièces De Montage

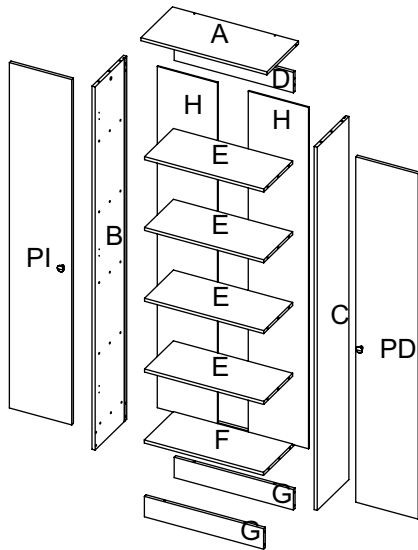

A - x1	E - x4	PI - x1
B - x1	F - x1	PD - x1
C - x1	G - x1	
D - x1	H - x2	

## CARGAS MÁXIMAS SUGERIDAS

### Max Suggested Load

### Charges Maximales Recommandées



# Cómo funcionan los tarugos y minifix?

## ¡IMPORTANTE

Cada vez que vaya a utilizar uno de estos durante el armado, sigue los pasos que te indicamos aquí.

## Tarugo

Son pequeños cilindros de madera.

1

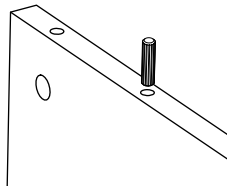

Inserta el tarugo en la perforación indicada y golpéalo suavemente hasta que llegue hasta el final de la perforación.

2

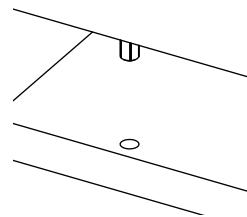

Al unir dos piezas, no olvides golpear un poco las piezas para ajustar el ensamblaje.

## Minifix

Es un pequeño sistema de unión que se compone de dos partes: una caja minifix y un perno.

1

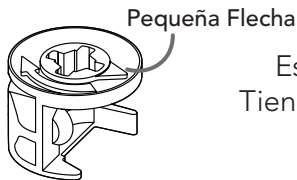

Esta es una caja minifix. Tiene una pequeña flecha en su parte superior.

3

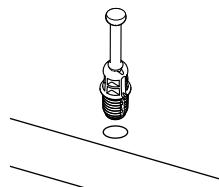

Este es un perno. Debes insertarlo con la parte plástica hacia abajo.

2

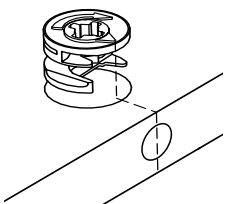

Debes insertar las cajas minifix con la flechita apuntando hacia la perforación que hay en el borde de la pieza.

4

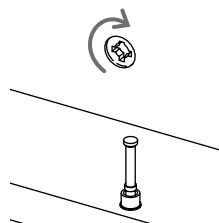

Luego de unir las piezas, debes girar 180° las cajas minifix con un destornillador de estrella para ajustar y asegurar el ensamblaje.

# How do the dowels and Minifix system work?

## This is so important too

Everytime you're using one of these connectors during the assembly, you should follow these same steps.

### Wood dowels

They are little wooden cylinders.

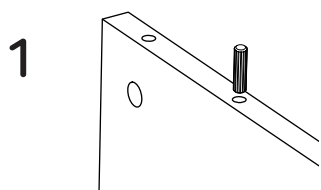

Put in the dowel inside the indicated hole and softly hit it until it's fully inside.

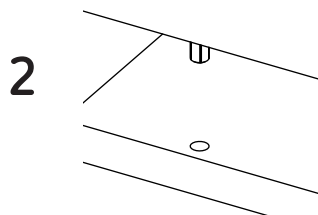

When joining two panels together, don't forget to gently hit the panels to adjust the joint.

### Minifix system

It's a joint compound of two parts: a spreading bolt and a Minifix cam.

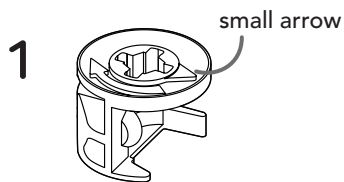

This is a Minifix cam. It has a little arrow on its upper surface.

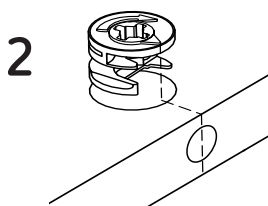

You should insert these cams with the little arrow pointing towards the drilling on the panel's edge (shown on the left).

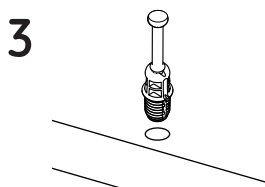

This is a spreading bolt. You should put it with the black plastic part facing down.

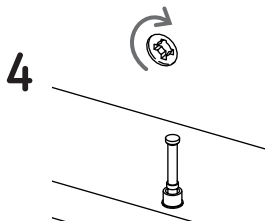

After joining two panels together you should turn the cams 180° with a phillips head screwdriver to adjust and secure the joint.

# Comment fonctionnent les chevilles et le système Minifix?

## C'est tellement important aussi

Chaque fois que vous allez les utiliser pendant le montage, suivez les étapes que nous vous indiquons ici.

### Cheville

Ce sont de petits cylindres en bois.

1

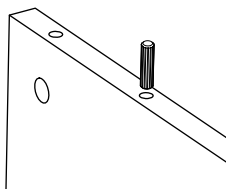

Insérer la cheville dans l'orifice indiqué en donnant de petits coups, l'enfoncer jusqu'au fond de l'orifice

2

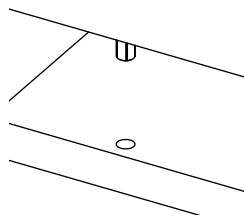

Lorsque vous assemblez deux pièces, n'oubliez pas de taper doucement sur celles-ci pour ajuster l'assemblage.

### Minifix

Il s'agit d'un petit système d'union composé de deux parties : une Came Minifix et un boulon.

1

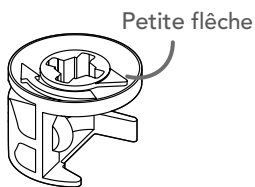

Ceci est une Came Minifix. Il y a une petite flèche sur la partie supérieure.

3

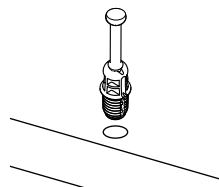

Ceci est un boulon. Il doit être inséré avec sa partie en plastique vers le bas

2

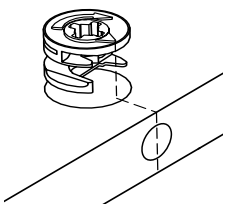

Les Cames minifix doivent être insérées avec la petite flèche vers l'orifice qui se trouve sur le bord de la pièce.

4

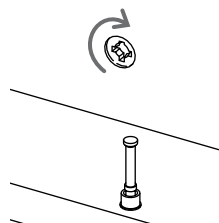

Après avoir uni les pièces, il faut visser à 180° les cames minifix avec un tournevis cruciforme pour ajuster et fixer l'assemblage

1

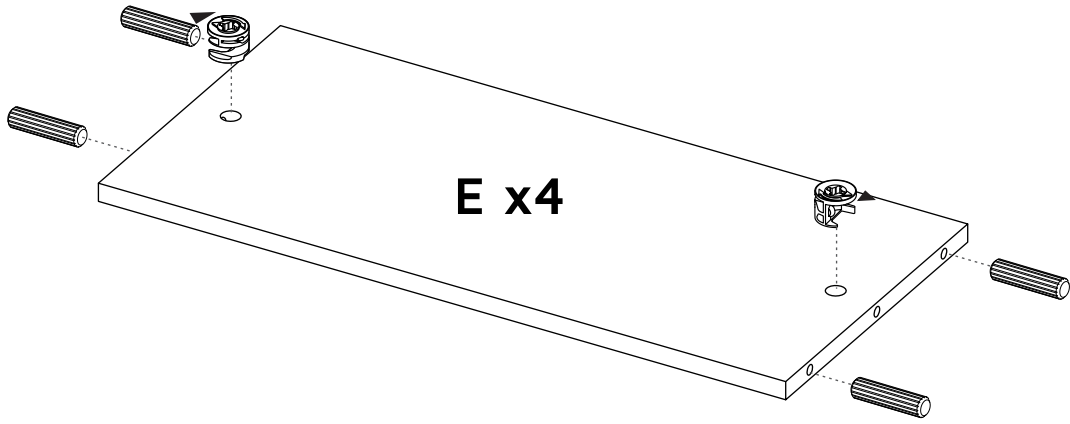

2

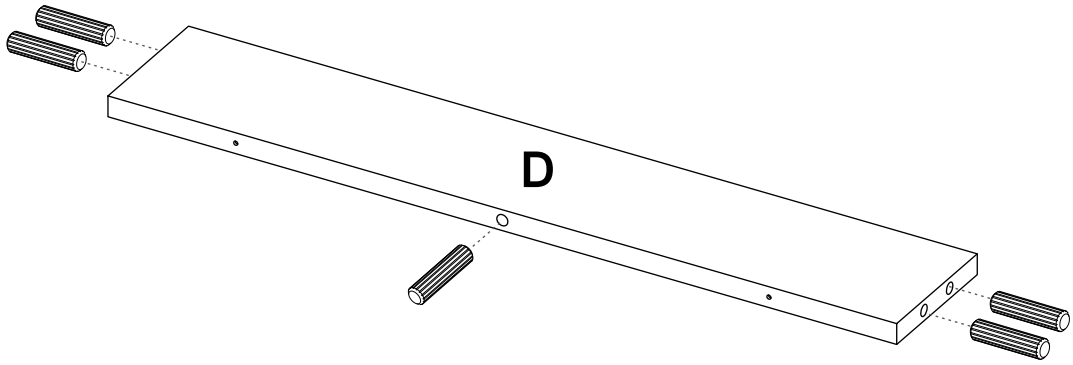

3

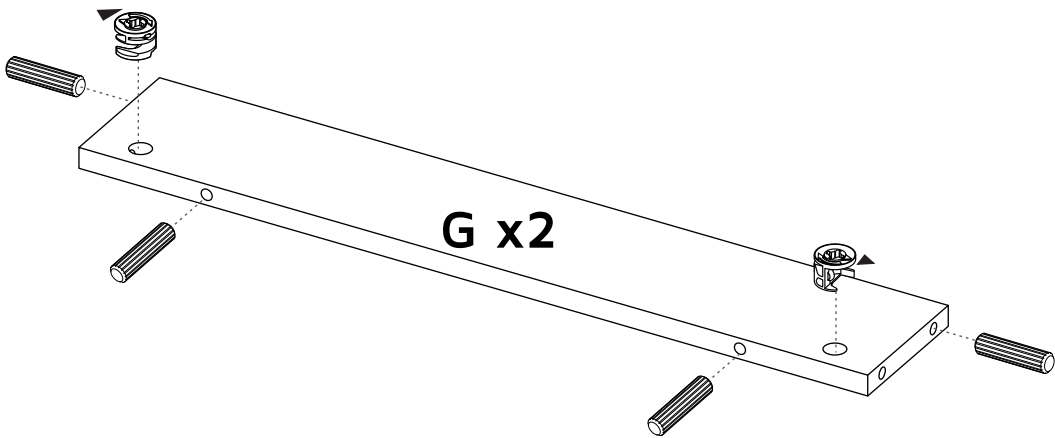

4

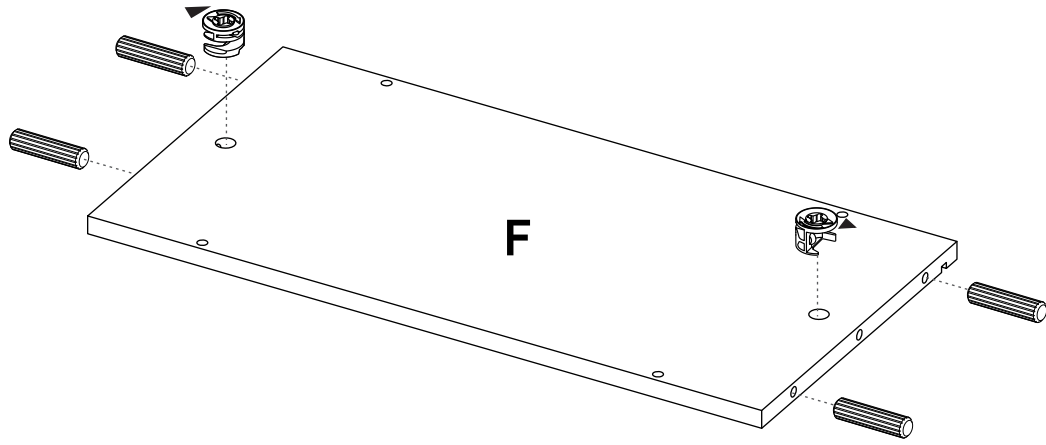

5

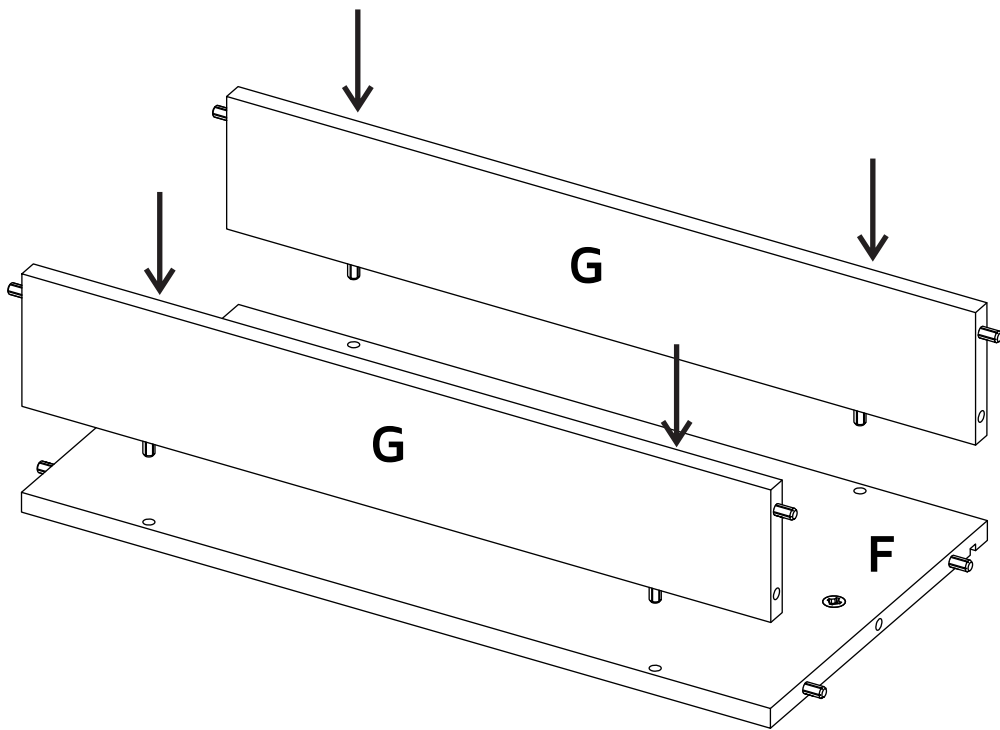

6

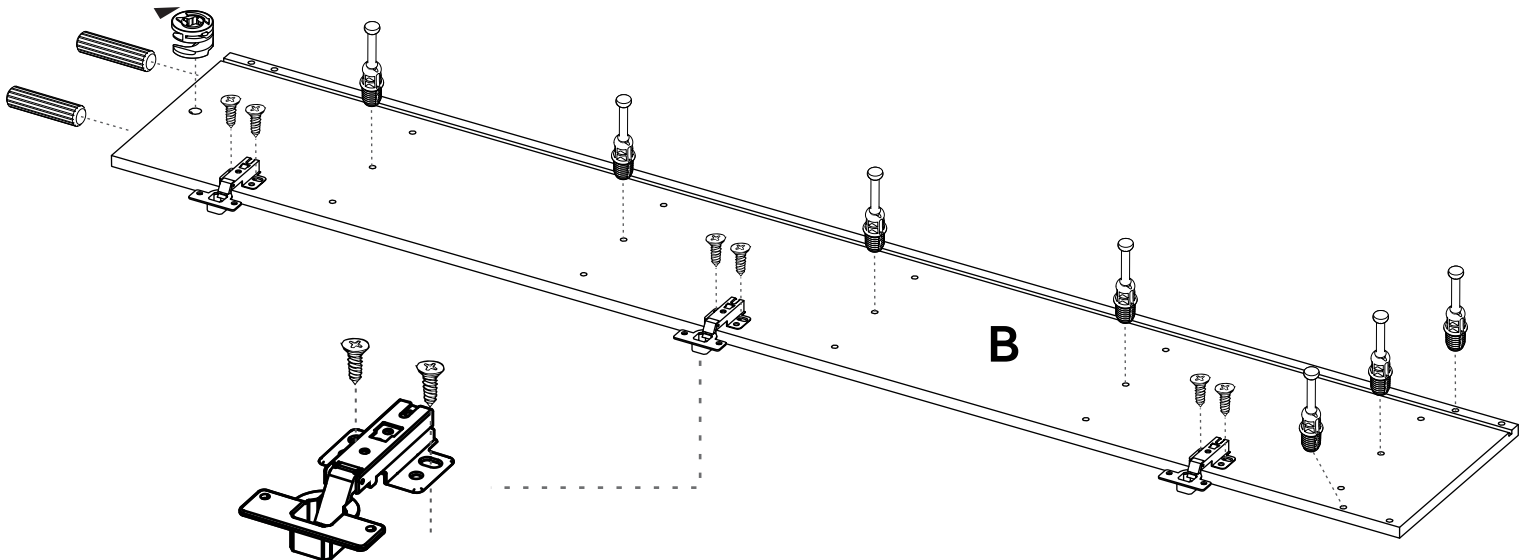



7

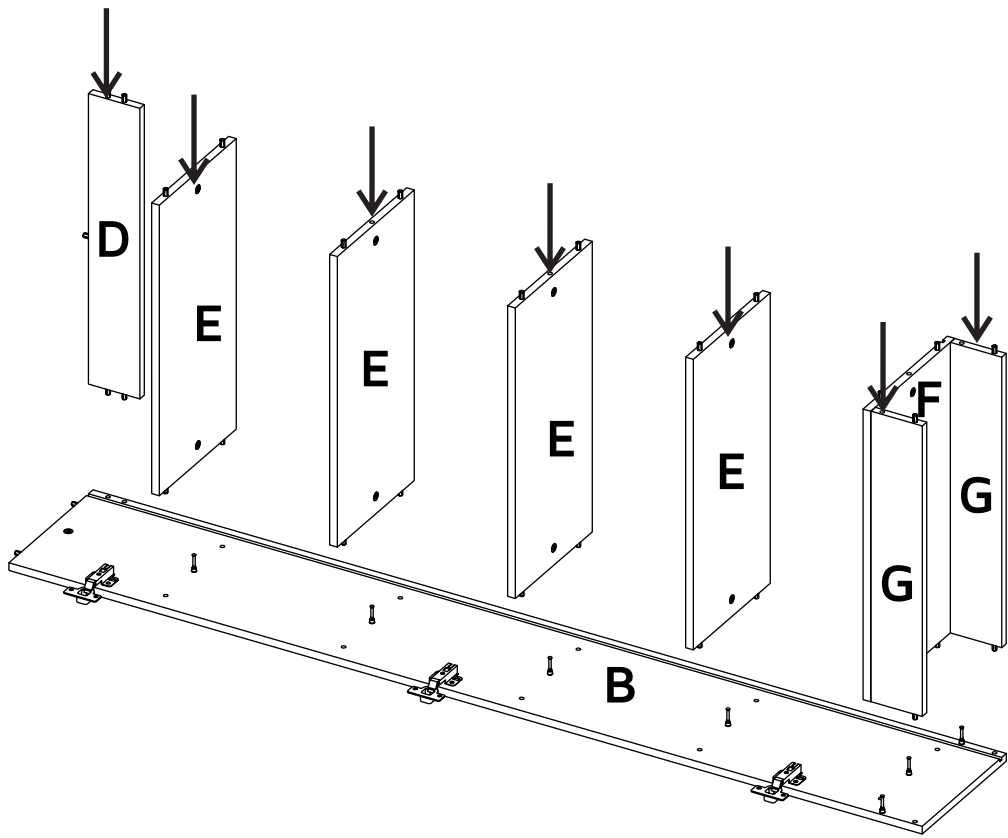

8

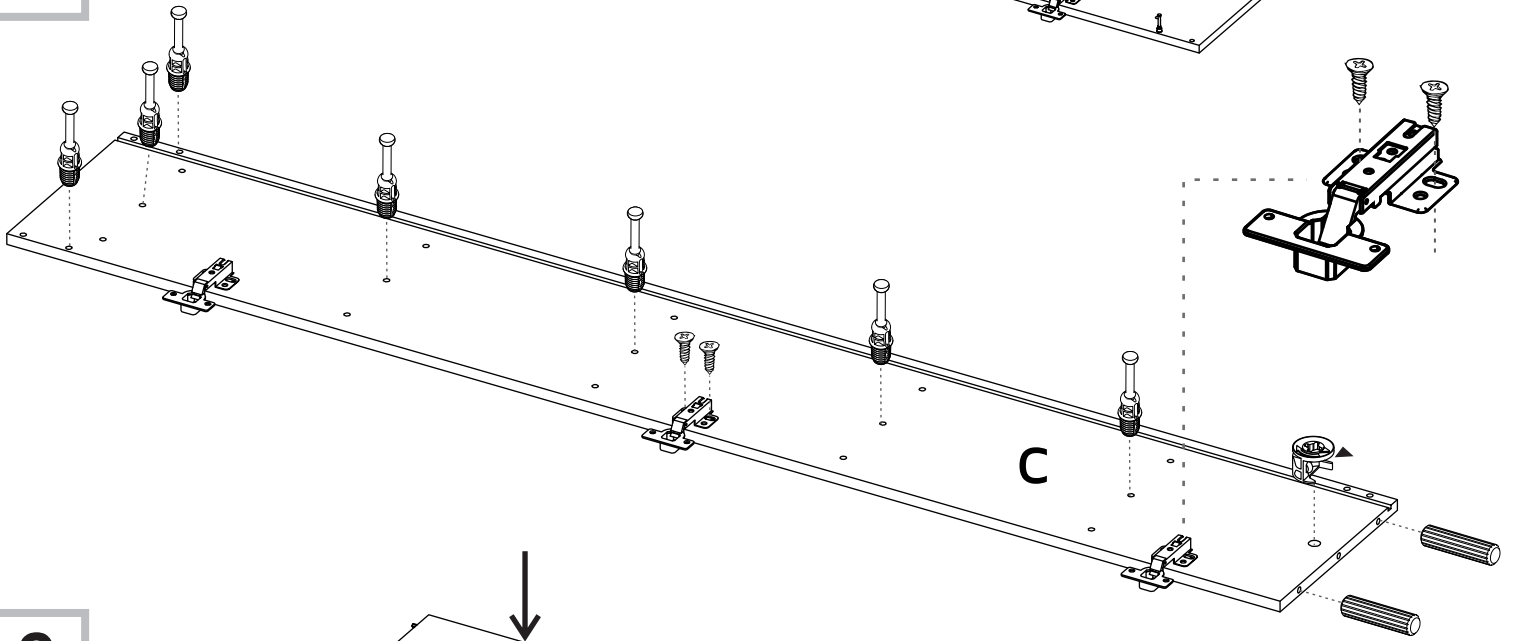

9

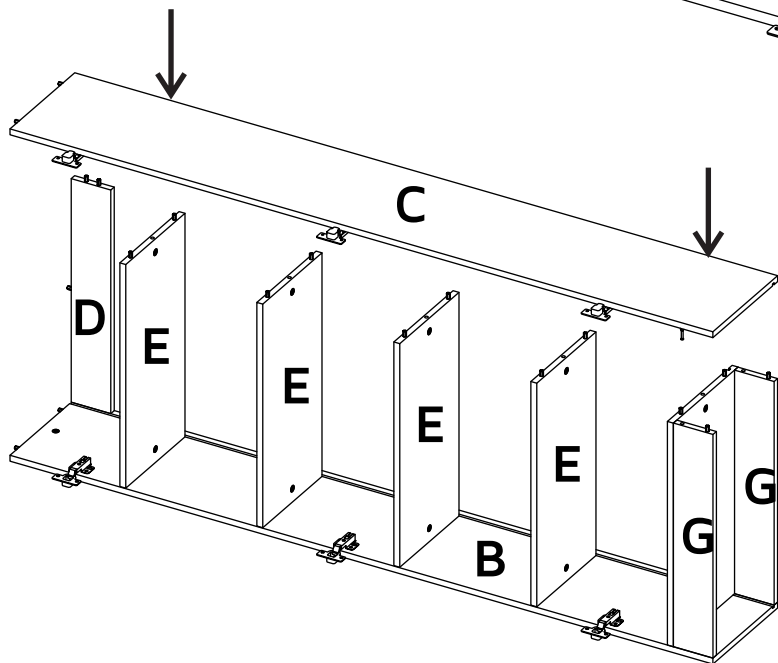

10

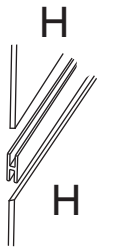

Perfil H  
H profile/  
Profil H

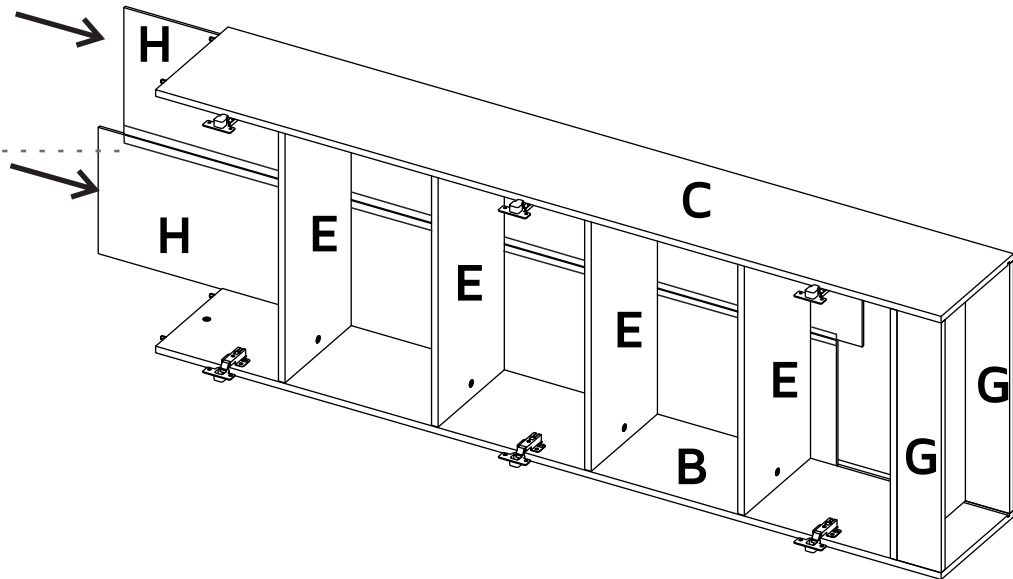

11

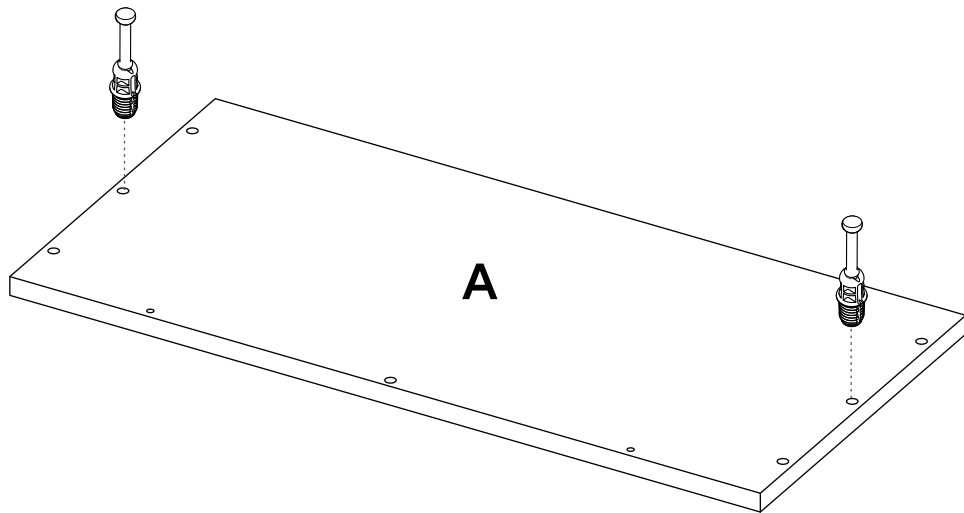

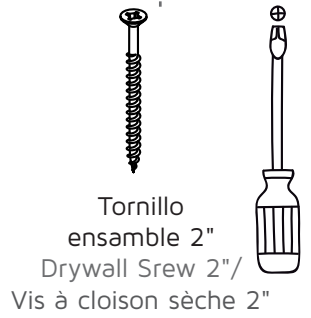
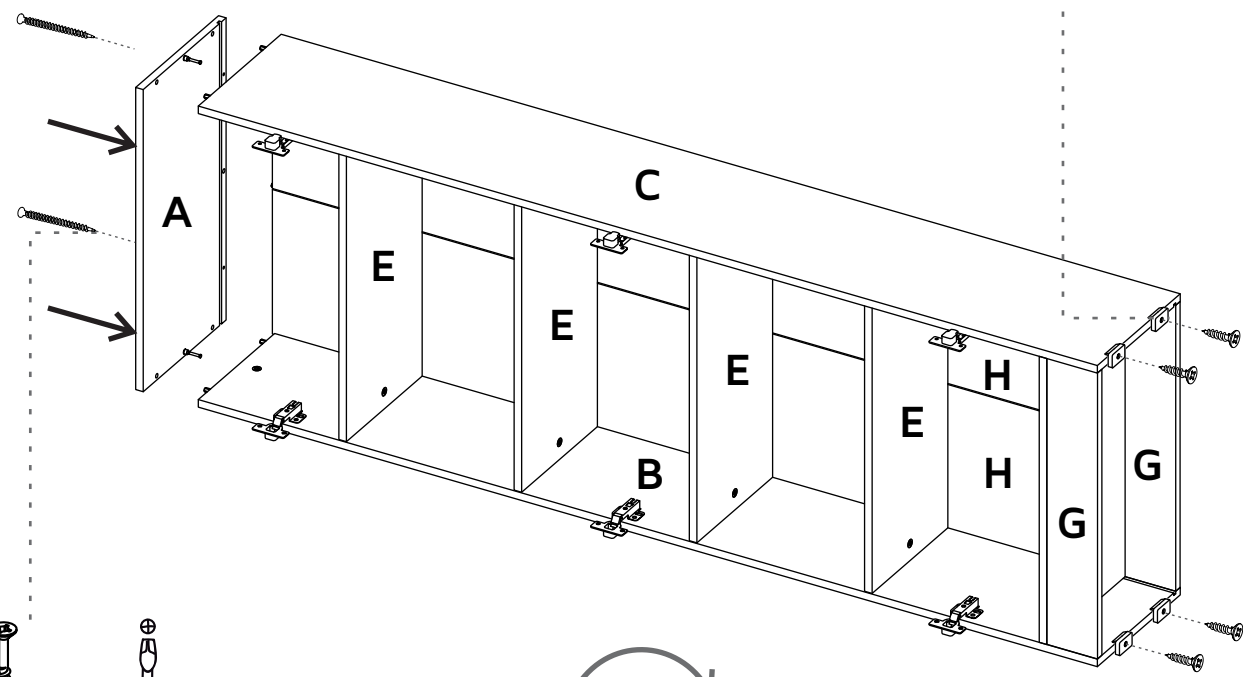
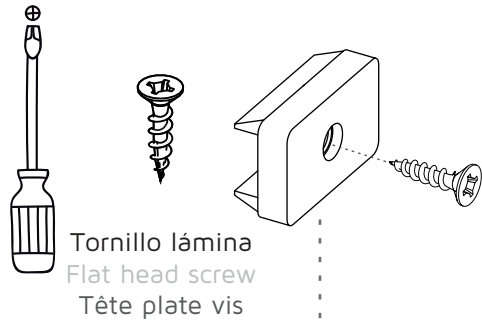

¡Con mucho cuidado!

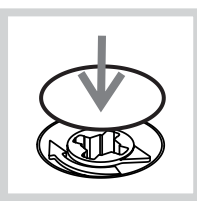
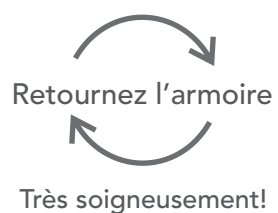

Después de ajustar todas las cajas minifix, cúbreelas con las tapas adhesivas.

After you finish the adjustment of the cams, cover them with the cover caps.  
Après avoir terminé le réglage des cames, les couvrir avec les caches.



Quando termines de armar, desprende los adhesivos de las letras en cada pieza

After you finish assembling the cabinet, take oof the adhesive letters.  
Une fois le montage de l'armoire terminé, retirer les lettres adhesives.



# OBLIGATORIO FIJAR A LA PARED



Utilice los tornillos y chazos adecuados para su muro

Existe una gran diversidad de muros y paredes, por esta razón no podemos proporcionarle el herraje adecuado para su pared. Primero, es necesario identificar el tipo de pared para luego utilizar el herraje adecuado. En caso de duda, diríjase a una tienda especializada para más información.



# OBLIGATORY FIX ON THE WALL



Use screws and plugs suitable for yours wall

Due to the wide diversity of wall or partition types, we cannot provide you with suitable attachment fixtures. To determine which attachment fixtures to use, you will need to identify the type of wall to which you will be fixing this product. If you have whatever doubt, please, go to one specialised shop for further information.



# FIXATION MURALE OBLIGATORIE



Utilisez des vis et des chevilles adaptés a vos murs

Il existe une grande diversité de types de murs ou cloisons, c'est la raison pour laquelle nous ne pouvons vous fournir un outillage adapté à chaque mur. Tout d'abord, il est nécessaire d'identifier le type de mur sur laquelle sera fixé ce produit afin de se procurer les fixations appropriées. En cas de besoin, pour toute information complémentaire, s'adresser à un magasin spécialisé.

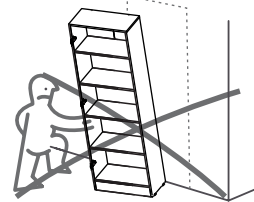
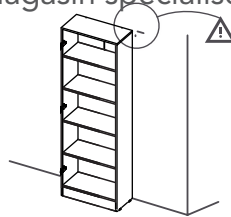

13

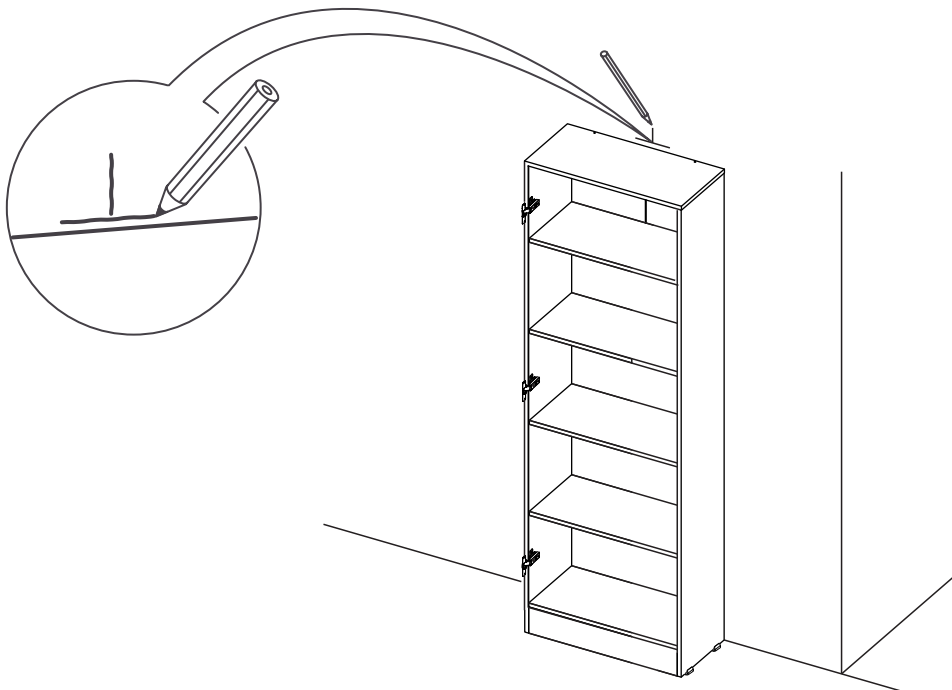

14



# OBLIGATORIO FIJAR A LA PARED



Obligatory Fix On the Wall / **Fixation Murale Obligatorie**

## Opción 1 Option 1/Option 1

- Kit Antivuelco
- + Tornillos
- Wall Fixing Kit
- + Screws/
- Kit de fixation murale
- + Vis

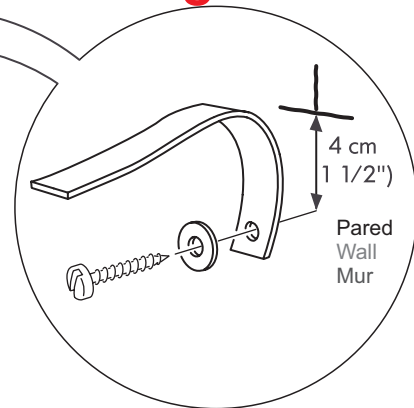
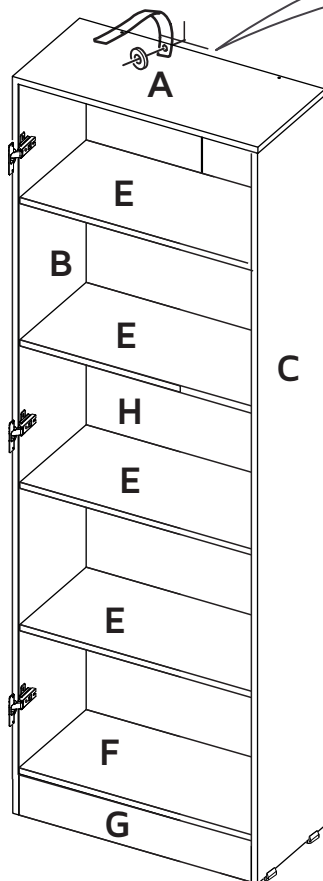

15

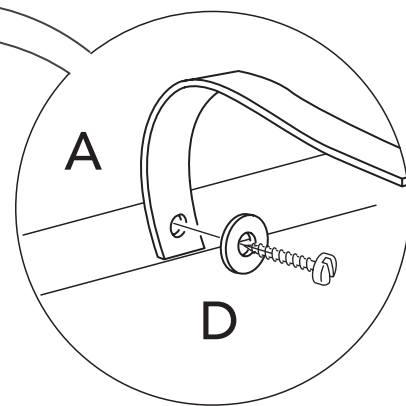
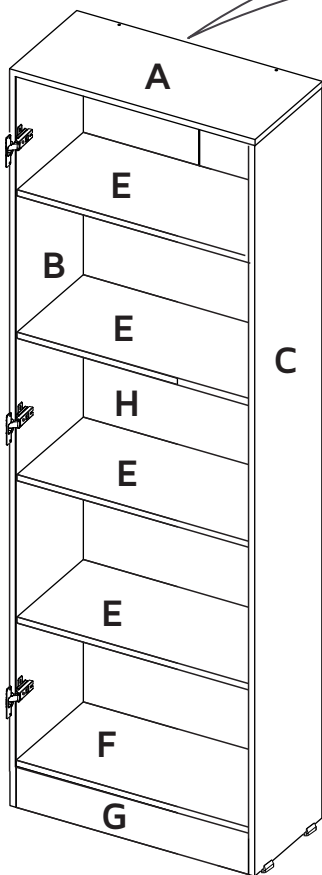

## Spanish

**IMPORTANTE:** Para evitar el vuelco accidental de los muebles, es obligatorio fijarlos en la pared. El tipo de tornillos necesarios para fijar el mueble a la pared, depende del material de la pared, no se suministran. En caso de duda, consulte a un especialista.

## English

**IMPORTANT:** To avoid the accidental tip-over of the furniture, the fixing of the furniture on the wall is mandatory.  
The needed hardware for the junction wall/furniture, depending of the nature of the wall, is not provided. If any doubt, consult a specialist.

## French

**IMPORTANT:** Pour éviter le basculement accidentel du meuble, la fixation du meuble au mur est obligatoire.  
La visserie nécessaire pour la jonction mur/meuble, dépendante de la nature du mur, n'est pas fournie. En cas de doute, consulter un spécialiste.

## Portugese

**IMPORTANTE:** Para evitar a queda accidental del móveis, é obrigatorio fixá-los na parede. O tipo de parafusos para a fixação de mobiliário na parede, depende do material de parede e não são fornecidos. Em caso de dúvida, consulte um especialista.

## Italian

**IMPORTANTE:** Per evitare il ribaltamento accidentale del mobile é obbligatorio il fissaggio a muro.  
I tasselli necessari per il collegamento mobile/muro, dipendenti dal tipo di muro, non sono provvisti. Consultare uno specialista in caso di dubbi.

## Croatian

**Važno:** Kako bi se izbjeglo slučajno prevrtanje, namještaj je potrebno pričvrstiti na (uza) zid. Različite vrste zidova zahtijevau upotrebu različitih vrsta vijaka i tipli. Uvijek koristiti one koji su prikladni za vrstu zidova u domu. Vijci i tiple prodaju se zasebno. U slučaju bilo kakvih sumnji, obratite se stručnjaku.

## German



**WICHTIG:** Um ein versehentliches Kippen des Möbels zu vermeiden, ist die Befestigung an der Wand zwingend vorgeschrieben.  
Die benötigten Schrauben zur Wandbefestigung, welche von der Beschaffenheit der Mauer abhängen, sind nicht in der Lieferung enthalten. Wenden Sie sich bitte bei Zweifel and einen Spezialisten.



Debido a la amplia diversidad de tipos de paredes o divisiones, no podemos proporcionarle accesorios de fijación adecuados. Para determinar qué accesorios de fijación utilizar, deberá identificar el tipo de pared a la que fijará este producto. A continuación se muestran algunos ejemplos de accesorios de fijación recomendados para:

### MUROS DE MAMPOSTERIA

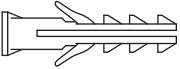
### MUROS DE CONSTRUCCIÓN LIVIANA.

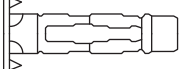
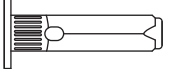
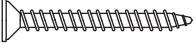
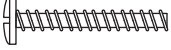
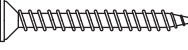
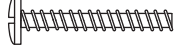
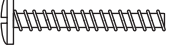
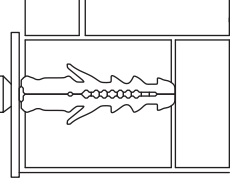
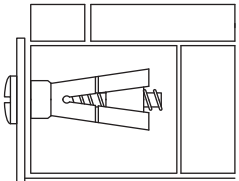
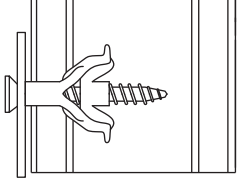
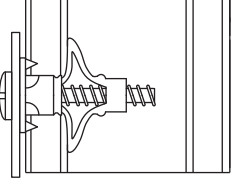
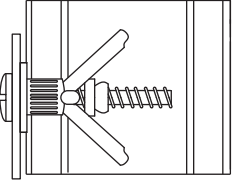
Taco de Nylon Tipo "Fischer"	Taco metalico	Taco de Nylon Tipo arpón	Taco metálico tipo ancla	Taco metalico Tipo "MOLLY"
				
				
				





Utilice una broca que sea compatible en tamaño con el hardware utilizado y el tipo de pared.



Due to the wide diversity of wall or partition types, we cannot provide you with suitable attachment fixtures- To determine wich attachment fixtures to use, you will need to identify the type of wall to which you will be fixing this product. Here are some examples of attachment fixtures recommended for:

### BLIND WALLS

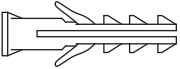
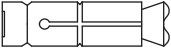
### STUDED WALL

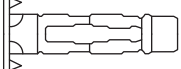
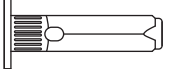
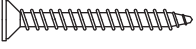
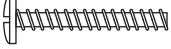
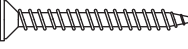
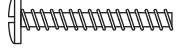
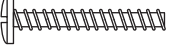
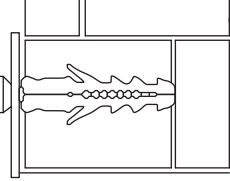
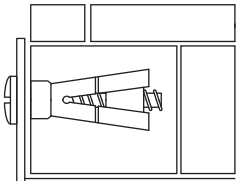
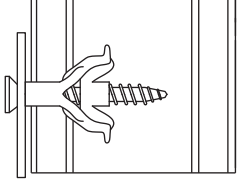
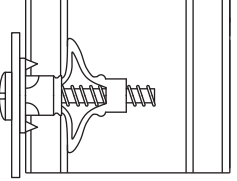
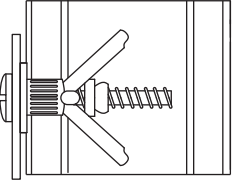
"Fischer" Nylon plug	Metal Wall plug	Nylon winged Wall plug	Metal expansion plug	"MOLLY" PLUG
				
				
				



Use a drill bit that is compatible in size with the hardware used and the type of wall.



Il existe une grande diversité de types de murs ou cloisons, c'est la raison pour laquelle nous ne pouvons pas vous fournir le type exact de fixation adapté au vôtre. Il est nécessaire d'identifier le type de mur sur lequel vous allez fixer ce produit, afin de vous procurer les fixations appropriées. Voici quelques exemples de fixations recommandées pour :

### LES MURS EN MAÇONNERIE

### LES CLOISONS CREUSES

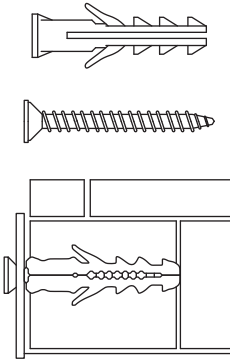
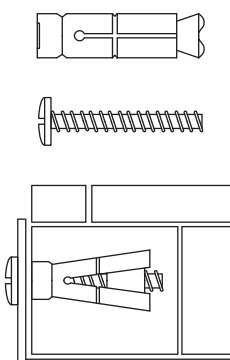
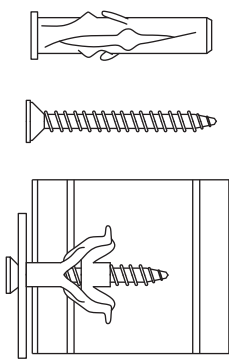
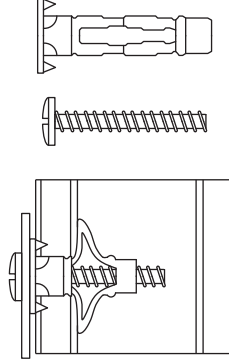
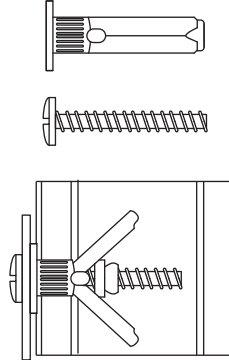
Cheville nylon "Fischer"	Cheville d'ancrage métal	Cheville d'ancrage à ailettes en nylon	Cheville métallique à expansion	Cheville "MOLLY"
				



Utiliser une taille de foret adaptée à la quincaillerie utilisée et au type de mur.



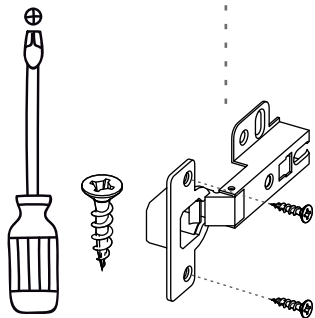
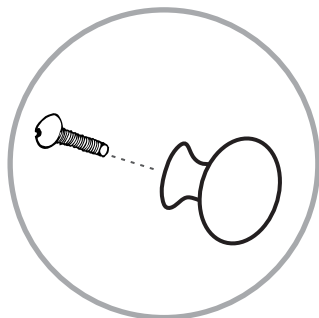
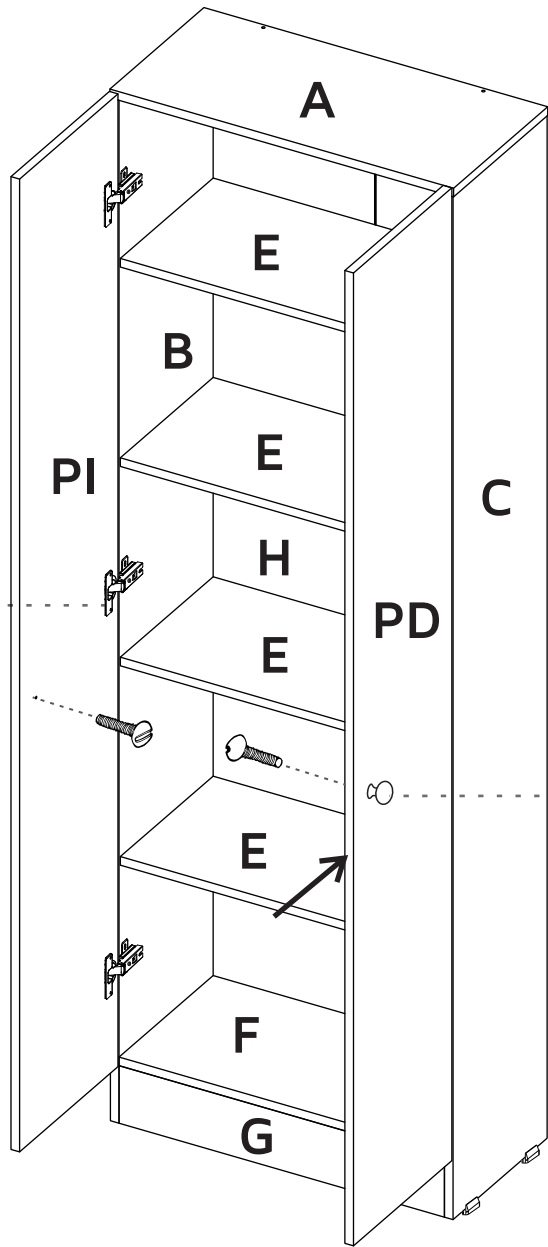

Instalación Puerta  
Door installation/Pose de porte

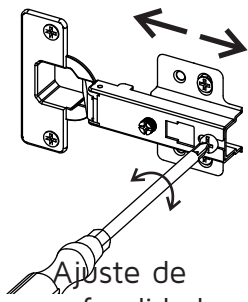

Ajuste de profundidad  
Depth adjustment/  
Profondeur ajustement

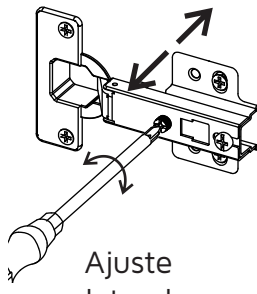

Ajuste lateral  
Lateral adjustment/  
Ajustement latéral

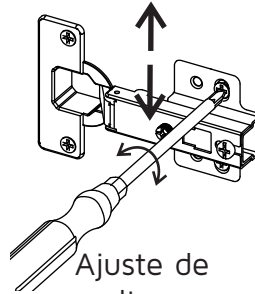

Ajuste de altura  
Height adjustment/  
Hauteur ajustement

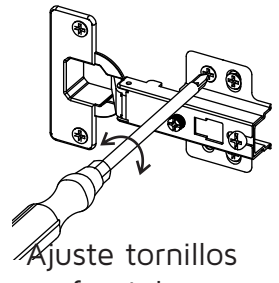

Ajuste tornillos frontales  
Front screws adjustment/  
Vis avant ajustement

## Derechos legales generales

En virtud de la normativa vigente en materia de consumidores, el cliente goza de una garantía legal, a contar desde la entrega del artículo.

## Condiciones de la garantía

Para que esta garantía sea válida, debe escribir a nuestro correo electrónico de servicio al cliente describiendo el defecto del producto, el número de lote y la presentación de la factura o prueba de compra del producto; o puede contactarse telefónicamente con nuestra línea de servicio al cliente. Las piezas reemplazadas estarán bajo el periodo de cobertura de garantía original del producto. Las piezas dañadas pasarán a hacer propiedad de la empresa.

Los muebles cuentan con un periodo de cobertura de garantía de 1 año en partes de madera y en partes de ferretería desde su fecha de entrega, la cual se puede ver en el número de lote impreso en la caja del producto y en el instructivo de armado.

En caso de no conformidad con el artículo adquirido, este dispone de devolución siempre y cuando se haga dentro de los 14 días siguientes a su recepción en el domicilio.

## ¿Qué cubre esta garantía?

La garantía cubre defectos en materiales y mano de obra que impiden el correcto armado y funcionamiento del mueble.

## ¿Qué no cubre esta garantía?

Esta garantía no es válida si los defectos o imperfecciones son causadas por el incorrecto seguimiento de las instrucciones de armado, advertencias y recomendaciones, mal uso, daño intencional, fuego e inundaciones, o luego de modificaciones o alteraciones del producto de cualquier tipo, o reparaciones realizadas por personas no autorizadas por DEPOT ESPAÑA después de 3 meses luego de haber sido armado el producto. Estos defectos DEBEN ser reportados antes de la finalización del periodo de cobertura de la garantía. Una vez el producto haya sido armado, la empresa no se hace responsable por piezas defectuosas o que hayan sido dañadas.

Esta garantía es válida SOLO para el COMPRADOR ORIGINAL, no aplica si el producto ha sido alquilado o revendido.

no se asumirá ninguna responsabilidad por daños incidentales o consecuentes causados a o por el producto.

No hay otras garantías aplicables a este producto

## General legal rights

Under current consumer regulations, customers have a legal guarantee. we will respond to any product non-conformity within the guarantee period, which begins when the item is delivered.

## Guarantee conditions

To make this warranty valid you must write to our customer service email describing the product defect, lot number and submitting your sales receipt or proof of purchase, or contact us at our customer service line. Replaced parts will be under the product's original warranty coverage period. Damaged parts will become property of the company.

Furniture has a 1 year warranty coverage in wooden parts and hardware pieces since its delivering date, which you can see in the lot number printed on the product box and the assembly instructions leaflet.

In case of non-conformity with the purchased item, it can be returned as long as it is made within 14 days of its receipt at home.

## What does this guarantee cover?

Warranty covers materials and workmanship imperfections which impair the assembly or correct functioning of the cabinet.

## What does this guarantee not cover?

This warranty is not valid if the defects or imperfections are caused by the incorrect following of the assembly instructions, warnings and recommendations, misuse, intentional damage, fire or flood, or after modifications or any kind of alteration, or repaired by someone not authorized when it's been assembled 3 months after the date of purchase. These defects MUST be reported before the warranty coverage period ends. Once the product has been assembled, the company will not be responsible for defective and/or damaged parts.

This warranty is ONLY valid for the ORIGINAL PURCHASER, it doesn't apply if the product has been resold or rented.

will take no liability for incidental or consequential damages caused to or by the product.

There are no other warranties applicable to this product.

## Droits légaux généraux

En vertu de la réglementation en vigueur en matière de consommateurs, le client bénéficie d'une garantie légale, répondant à la non-conformité de ses produits dans ce délai, à compter de la livraison de l'article.

## Conditions de la garantie

Pour que cette garantie soit valide, vous devez écrire à notre courriel de service clientèle décrivant le défaut du produit, le numéro de lot et la présentation de la facture ou de la preuve d'achat du produit ; vous pouvez aussi contacter par téléphone notre ligne de service clientèle. Les pièces remplacées seront soumises à la période de garantie initiale du produit. Les pièces endommagées deviendront la propriété de l'entreprise.

Les meubles bénéficient d'une période de garantie d'un an sur les pièces en bois et d'une couverture de garantie d'un an sur les pièces de quincaillerie à partir de leur date de livraison, qui apparaît dans le numéro de lot imprimé sur la boîte du produit et dans les instructions de montage.

En cas de non-conformité de l'article acheté, celui-ci peut être retourné à condition que le retour soit effectué dans les 14 jours suivant sa réception au domicile..

## Que couvre cette garantie ?

La garantie couvre les défauts de matériaux et de main-d'œuvre qui empêchent le bon assemblage et le bon fonctionnement du meuble.

## Qu'est-ce qui n'est pas couvert par cette garantie ?

Cette garantie n'est pas valable si les défauts ou imperfections sont causés par un mauvais suivi des instructions de montage, des avertissements et des recommandations, par une mauvaise utilisation, par des dommages intentionnels, par des incendies et des inondations, ou par des modifications ou des altérations du produit de quelque nature que ce soit, ou encore par des réparations effectuées par des personnes non autorisées par DEPOT ESPAÑA /DÉPÔT ESPAGNE plus de 3 mois après le montage du produit. Ces défauts DOIVENT être signalés avant la fin de la période de couverture de la garantie. Une fois le produit assemblé, l'entreprise n'est pas responsable des pièces défectueuses ou endommagées.

Cette garantie est valable SEULEMENT pour l'ACHETEUR ORIGINAL, elle ne s'applique pas si le produit a été loué ou revendu.

n'assume aucune responsabilité quant aux dommages accessoires ou conséquents causés sur le produit ou par celui-ci.

Aucune autre garantie ne s'applique à ce produit.