

WATERSNAKE[®]

SLIDER XB

BOW MOUNT ELECTRIC MOTOR

OWNERS MANUAL



**Jarvis
Marine[®]**

www.jarviswalker.com.au

WATERSNAKE ELECTRIC MOTORS

Congratulations and welcome to a world of silent motoring. Powerful yet silent, the Watersnake electric motors are built to suit all angling conditions. High quality materials, superior design and precision engineering make these motors longwearing and reliable.

ATTACHING THE MOTOR TO YOUR BOAT

The slider mount integrates a quick release bracket mechanism. Simply attach the lower plate to your boat, place the upper mount in position, tighten the lock screw and you are ready for the water. To release the motor simply unscrew the locking plate lock screw located within the mount.



Locking
Plate Screw



SLIDER

WATERSNAKE



SET UP

Pulling the locking mechanism will release the locking collar and allow you to slide the motor forward and away from the mounting bracket. Lower the motor to the required depth making sure that it locks into the vertical position securely. It is important to ensure the shaft is locked into the vertical position otherwise the power will not flow to the motor.

DEPTH ADJUSTMENT

Hold the motor shaft with one hand, loosen the depth adjustment screw and set the motor to the desired depth. Then retighten the adjusting screw securely.

STOWING

When the Watersnake is not in use always stow it properly. Release the tilt lock lever and raise the motor and pull towards the stern until it is secure on the ramp and locked in the horizontal position out of the water.

FOOT PEDAL CONTROL SYSTEM

The low profile foot pedal control is used to adjust direction and speed. A speed control lever is located at the right side of the foot control box.

- (1) Steering is enabled via the large pedal. Pushing down at the top left hand corner of the pedal with your foot will turn the motor to the left
- (2) To steer to the right push your foot down at the top right hand corner of the pedal.
- (3) Use your heel at the bottom of the pedal to pause or resume thrust (power)
- (4) A constant on/off switch is set at the left hand side of the foot pedal control box.
- (5) Speed control wheel.

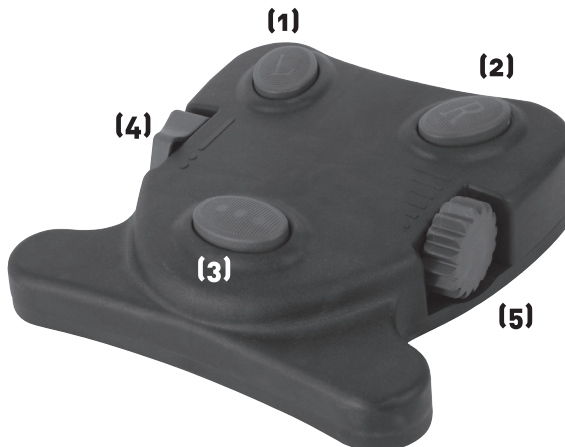

WATERSNAKE

CHANGING THE PROPELLOR

Before doing anything with the propeller, ensure the cables to the battery are disconnected.

To detach the propeller it is a simple matter of unscrewing and removing the locknut using the special tool supplied. When doing this, take hold of the propeller to stop it turning. Under no circumstances should you attempt to loosen the locknut with a hammer or similar tool as this may damage the locknut and/or shaft. (F)

Once the locknut is removed, the propeller can be taken off. When putting the propeller back on, verify there is a proper fit of the groove and shear pin otherwise the propeller will not be locked. (G)

After using the motor always check and clear any weed or fishing line that may have become tangled around the propeller. Next, give the motor a wipe down with warm water to remove any salt or sand particles and then rinse it with fresh water.

(F)

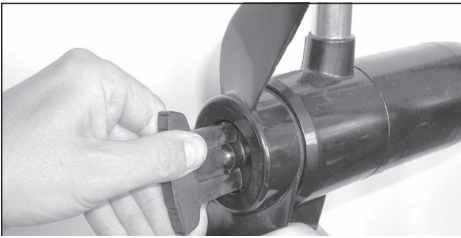

(G)

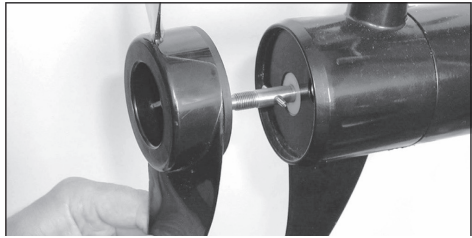

Watersnake Propeller Kits (Sold Separately)

Watersnake Propeller kits contain a propeller, propeller nut and shear pins. It is recommended you keep a spare propeller on your boat at all times. The Mini 2-Bladed Kit is suitable for the T-18 motors. The 2-Bladed Propeller Kit is suitable for 28lb, 30lb and 34lb motors. The 3-Bladed Medium Propeller Kit is suitable for all 44lb and 54lb motors. The 3-Bladed Large Propeller Kit is suitable for all 70lb, 80lb and 105lb motors.



55008
Large 3 Blade
Prop (70lb-105lb)



55130
3 Blade Prop
(44lb-54lb)



55131
2 Blade Prop
(28-34lb)



JM56001
2 Blade Mini Prop
(18lb)

ELECTRICAL CONNECTIONS

Before connecting the motor's cables to the battery terminals, ensure all switches are in the OFF position and stand clear of the propeller.

Connect the red cable to the positive (+) terminal and the black cable to the negative (-) terminal, making sure the terminals are clean before doing so. A clean connection will minimise power wastage and give you maximum power from the battery.

The battery should be kept in a well-ventilated location. We recommend using a special deep cycle marine battery for optimum performance.

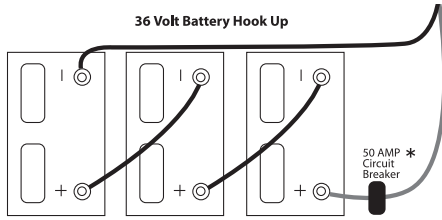
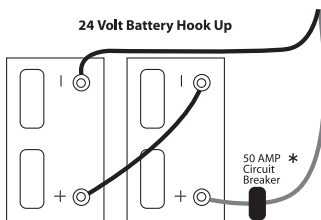
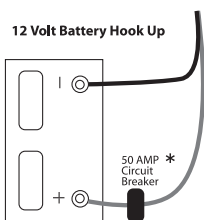
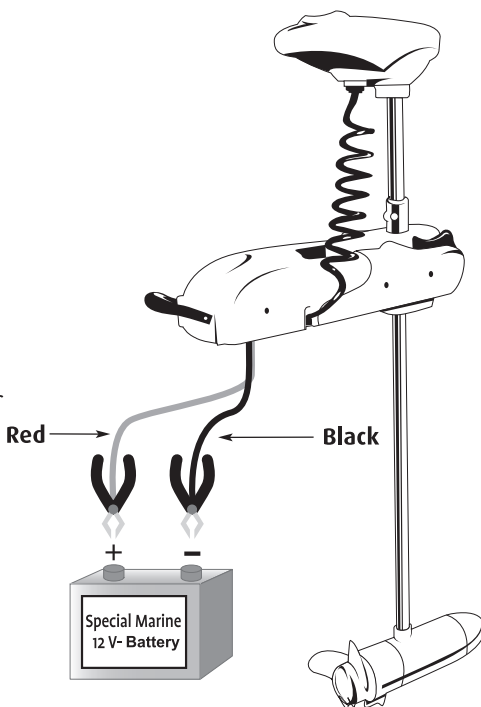

*Available separately

MODEL	MAX THRUST	CONTROL	VOLTAGE/AMPS	SHAFT MATERIAL	SHAFT LENGTH
SWXB 54/54	54lbs	By Foot	12V/48A	Composite	54"/135cm
SWXB 80/54	80lbs	By Foot	24V/48A	Composite	54"/135cm
SWXB 80/60	80lbs	By Foot	24V/48A	Composite	60"/152cm
SWXB 105/54	105lbs	By Foot	36V/53A	Composite	54"/135cm
SWXB 105/54	105lbs	By Foot	36V/53A	Composite	60"/152cm

WATERSNAKE

TROUBLESHOOTING

PROBLEM

POSSIBLE CAUSE/SOLUTION

Speed loss

- 1: Check for line or weed on propeller.
- 2: Check battery status.
- 3: Check terminals on battery.

Motor noise/ shake

- 1: Check propeller for line or weed.
- 2: Check to see propeller is secure and not damaged.
- 3: Check shaft to ensure it is not bent. Detach propeller and run motor visually to ensure shaft is not shaking. If shaft is damaged contact your retailer or service centre.

Loss of speed setting

- 1: Check all wiring connections.
- 2: Speed coil in motor may be burned, contact your retailer or service centre.

Tight steering

- 1: Loosen counterforce screw, apply lubricant and re-adjust.

For problems not listed contact your retailer or service centre.

MAINTENANCE

At the end of the day, wipe the motor down with a cloth soaked in warm water and then rinse unit with light spray from hose. Always check the propeller is clear of line or weed, regularly check all nuts, bolts and screws and lubricate all moving parts with an aerosol lubricant. Clean terminal connections regularly and check for frayed wires or loose connections.

STORAGE

When storing the motor, lubricate all moving parts and screws and store in a well-ventilated, dry area. Do not leave the motor outside in winter for long periods, as this will damage the permanent magnet in the unit.

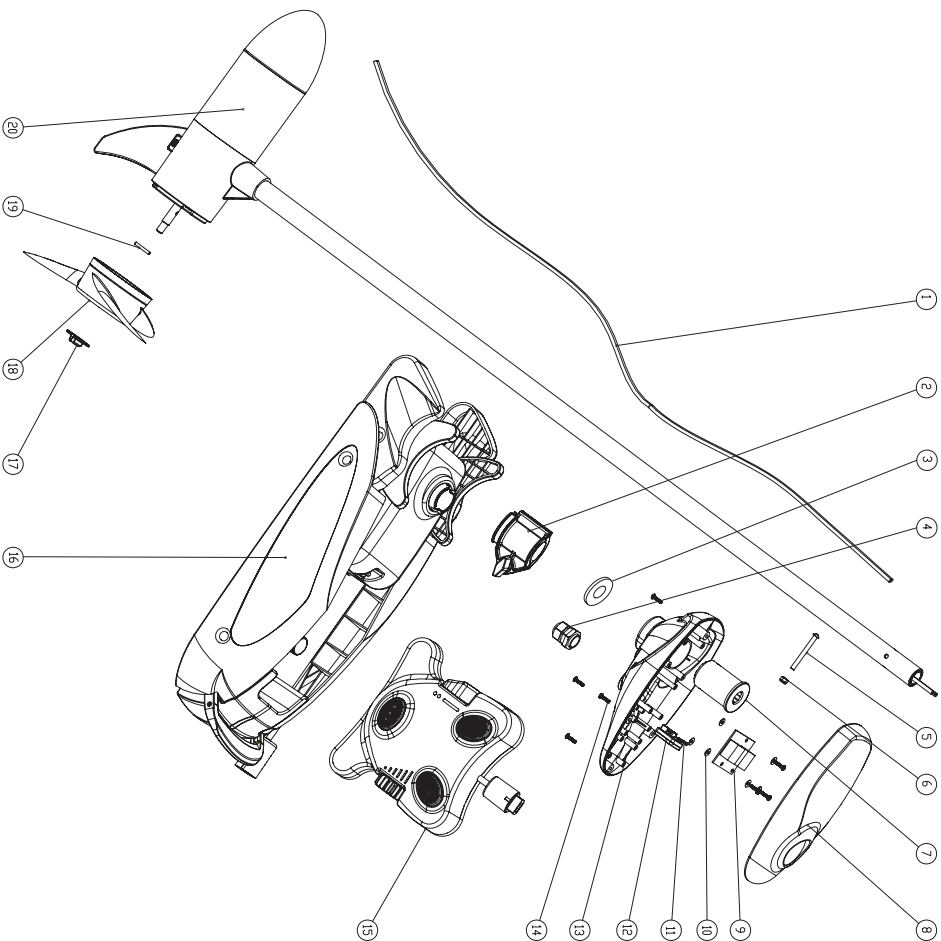

19	HP6, 593, 002, 00	Prop	1
18	HP6, 482, 001, 00	Prop Nut	1
17	HP6, 125, 013, 00	Bow Mount Assy (SMXB105/54, SMXB105/60)	1
16	HP6, 125, 013, 00	Bow Mount Assy (SMXB105/54, SMXB105/60)	1
15	HP6, 041, 000, 00	Foot control pedal	1
14	HP8, 076, 030, 70	Bottom Cover	7
13	HP6, 708, 001, 00	Transducer	1
12	HP8, 903, 042, 00	Boit	1
11	HP8, 940, 031, 00	Washer	2
10	HP6, 672, 034, 00	Relay Control Board (SMXB105/54, SMXB105/60)	6
9	HP6, 672, 005, 00	Relay Control Board (SMXB105/54, SMXB105/60)	1
8	HP8, 076, 029, 70	Top Cover	1
7	HP8, 210, 365, 00	Sleeve	1
6	HP6, 482, 002, 45	Locking nut	1
5	HP8, 902, 197, 45	Boit	1
4	HP6, 428, 019, 00	Water Joint	1
3	HP8, 662, 083, 00	seal ring	1
2	HP6, 257, 011, 00	Depth Adjust Collar Assy	1
1	HP6, 647, 001, 00	Main Battery Cable	1
No.	Part Name	Description	Qty

SMXB Series

JARVIS MARINE INTERNATIONAL – 12 MONTH WARRANTY PROVISIONS

1. Product safety

Provision of the goods by Jarvis Marine in no way reduces the purchaser's obligation to ensure that their use of the goods and the relevant operating environment is safe and in accordance with Jarvis Marine's directions relating to care, maintenance and storage of the goods.

2. Product warranty

(a) All goods manufactured by Jarvis Marine that have been subjected to normal and proper use are warranted to be free from material defects in material and workmanship for a period of one year from the date of purchase.

(b) Jarvis Marine will use its reasonable endeavours to rectify at its cost any defect in the goods notified to it during the warranty period.

(c) The purchaser's sole remedy for a breach of clause 2(a) is the repair, replacement or resupply of the goods. Jarvis Marine will not be liable to rectify any defect in the goods if:

(1) the goods have been altered or modified without Jarvis Marine's authorisation;

(2) the defect is the result of or related to a failure of the purchaser to comply with any of its obligations under these terms;

(3) or the defect is the result of or related to the use of the goods other than in accordance with this documentation or Jarvis Marine's reasonable recommendations or directions.

3. Limitations on Liability

Limited and excluded liability

Unless this warranty provides otherwise, the maximum aggregate liability of Jarvis Marine for all proven losses, damages and claims arising out of this warranty, including liability for breach, in negligence or in tort or for any other common law or statutory action, is limited to the sum of the amount paid by the purchaser to Jarvis Marine. Notwithstanding any other provisions, Jarvis Marine will not be liable to the purchaser or to any other person for: any losses or damages of any kind caused by or resulting from any wrongful, wilful or negligent act or omission of Jarvis Marine or any of its officers, employees, agents or contractors; or any indirect, incidental, special or consequential damages, including loss of profits or anticipated profits, even if notified of the possibility of that potential loss or damage.

Exclusion of implied warranties.

Any representation, warranty, condition or undertaking that would be implied in this warranty by legislation, common law, equity, trade, custom or usage is excluded to the maximum extent permitted by law.

Non-excludable rights implied by statute.

Nothing in this warranty excludes, restricts or modifies any condition, warranty, right or remedy conferred on the purchaser by the Trade Practices Act 1974 (Cth) or any other applicable law and which cannot be excluded, restricted or modified by agreement. Liability for breach of non-excludable rights to the fullest extent permitted by law, the liability of Jarvis Marine for a breach of a non-excludable condition or warranty referred to and as otherwise provided for in these terms are limited, at Jarvis Marine's option, to the replacement of the goods or the supply of equivalent goods; the repair of the goods; the payment of the cost of replacing the goods or of acquiring equivalent goods; or the payment of the cost of having the goods repaired.

4. Warranty service

A copy of the proof of purchase or registration verification is required to obtain warranty service.

Please contact Anglers Central Service centre for servicing and Spare parts. Goods sent to repair centre at owners cost.

Anglers' Central Service Centre Pty Ltd; Australia's largest tackle repair centre and the authorised service and repair centre for all Penn, Rovex, Jarvis Walker and Jarvis Marine products throughout Australia.

email: spareparts@anglerscentral.com.au

Ph: 08 8244 8790 Free Fax: 1300 763 331

Delivery address: 2/7 Circuit Drive, Hendon SA 5014

When applying for a warranty service please supply proof of purchase and a brief explanation of the fault.

WATERSNAKE

Important

To make the warranty effective please complete this registration card correctly and return to us with a copy of your receipt within thirty (30) days after the date of purchase.

If you do not wish Jarvis Marine to send you information on our products and services please tick here.

Name and Model

Place of Purchase Date of purchase

Serial Number *

Purchaser's Name

Address

.....

Signature

**PLEASE ATTACH A COPY
OF PROOF OF PURCHASE
HERE.**

(RECEIPT)

YOU WILL REQUIRE IT TO MAKE A CLAIM.

SEND TO:

Jarvis Marine International Pty. Ltd.

297-305 South Gippsland Highway

Dandenong South, Victoria 3175 Australia

ACN: 133 252 294

Keep a copy of this information for your records.

* Serial number is located on the shaft of the motor.

WATERSNAKE®

CONTACT INFORMATION

REGION/COUNTRY	DISTRIBUTOR	PHONE
Asia Pacific		
Australia	Jarvis Walker	+61 3 8787 6900
(Tasmania)	Tas Fishing Supplies	+61 3 6248 5959
(West Australia)	Benbow Outdoors	+61 8 9302 5552
China	Jarvis Walker International	+86 21 6356 5078
New Zealand	Thompson Walker	+64 9 274 7740
USA		
USA	Watersnake Motors Inc.	+1 239 481 5649
Africa		
South Africa	Apex Walker	+27 11 7920 611
Russia		
Russia	Badger Ltd.	+7 812 321 8880
Europe		
Austria	Aquazona	+420 386 357 881
Belgium	SPRO BV	+31 347 320 888
Bosnia	Aquazona	+420 386 357 881
Bulgaria	Aquazona	+420 386 357 881
Czech Republic	Aquazona	+420 386 357 881
Denmark	Wiggler AB	+0303 798 744
Finland	Wiggler AB	+0303 798 744
France	SPRO BV	+31 347 320 888
Germany	SPRO BV	+31 347 320 888
Hungary	SPRO BV	+31 347 320 888
Ireland	Truetackle	+353 1 295 8255
Italy	Europesca Sport	+39 06 6500 2449
Luxembourg	SPRO BV	+31 347 320 888
Montenegro	Aquazona	+420 386 357 881
Netherlands	SPRO BV	+31 347 320 888
Norway	Wiggler AB	+0303 798 744
Poland	SPRO BV	+31 347 320 888
Romania	Aquazona	+420 386 357 881
Serbia	Aquazona	+420 386 357 881
Slovakia	Aquazona	+420 386 357 881
Slovenia	Aquazona	+420 386 357 881
Sweden	Wiggler AB	+0303 798 744
Turkey	TURAC Dist.	+90 532 707 8430
United Kingdom	Masterline Walker	+44 0 1684 299 000

AUSTRALIAN REPAIRS AND SERVICING

Anglers' Central Service Centre

2/7 Circuit Drive, Hendon

South Australia, 5014 Australia

Ph: 08 8244 8790

Email: spareparts@anglerscentral.com.au

www.jarviswalker.com.au

Jarvis Marine International Pty. Ltd.

297-305 South Gippsland Highway

Dandenong South, Victoria 3175 Australia

ACN: 133 252 294

Watersnake® and Jarvis Marine® are registered trademarks of Jarvis Marine International.

© 2009 Jarvis Marine International. All Rights Reserved. Specifications are subject to change without notice.