

TECHNICAL SPECS

WIRE SIZE	20 AWG Stranded 105C
INPUT VOLTAGE	12 - 16 VDC (Standard Automotive Battery)
INPUT CURRENT FUSE	7.5 MAX Amperage
REVERSE BIAS PROTECTION	Fuse will OPEN if Vin & GND are reversed to protect module.
OUTPUT VOLTAGE	13.6V typical (standard automotive battery power with engine running)
OUTPUT CURRENT	100W / 7.5A max current output with engine running (fuse protected)
SLEEP CURRENT	0 volt output, 180uA quiescent current (Vin < 12.8V / Key = OFF, Engine OFF)
ENGINE RUNNING	On when battery voltage increases / alternator charging
ENGINE OFF	OFF when battery voltage decreases / alternator not charging
SLEEP	Engine OFF / Module = OFF; no power output
RATINGS	IP54
OPERATING	-40°C ~ +85°C (USCAR Interior / Below IP)
STORAGE	-40°C ~ +125°C

WIRE CONNECTIONS

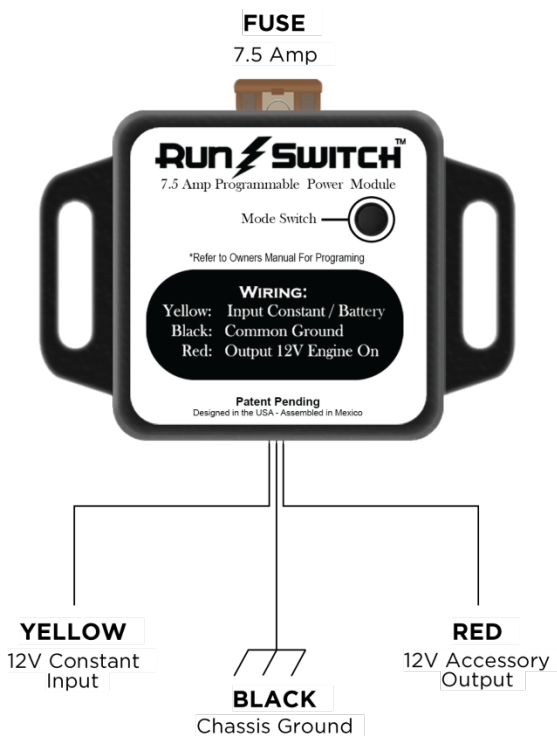

YELLOW: Connect directly to a 12V battery (+) terminal. This is the INPUT power to the RunSwitch module and requires a constant power connection directly from the 12V battery.

BLACK: Connect to system Ground. This could be the vehicle chassis or direct connection to the (-) terminal on the 12V battery.

RED: Connect this wire to the accessory (+) INPUT that is typically connected to 12V power. The accessory GROUND wire will require a connection to chassis or (-) to complete the circuit.

The RunSwitch will automatically detect when the vehicle engine is running and will provide power to the accessory device. The RunSwitch fuse will be illuminated to indicate power is available to the accessory device at that time. When the engine is turned OFF, the RunSwitch will automatically detect the loss of alternator charging and will turn OFF.

TIMER MODE

The timer function is the default mode (3-min) from the factory. The timer enables the accessory output to remain ON for a predetermined amount of time after the engine is turned OFF. The Timer Delay function is user-adjustable from 1 to 90 minutes. In Timer mode, the LED will blink when engine is OFF, indicating that the timer function is enabled and timer countdown is progressing. Once timer delay has elapsed, the LED & accessory output will turn OFF. Timer function will be repeated on next Engine ON/OFF cycle.

Typical Uses:

Accessory power for components that can be disabled after a delay once engine has been turned off.

The timer mode has a 2-Tier level for programming the delays

1X - 1-9 minutes (factory default 3-minute delay)

10X - 10-90 minutes

PROGRAMMING TIMER

STATUS:

Engine running, Module powered = ON, LED=ON, fuse illuminated.

TIME DELAY SETTING:

- With the engine running, hold push button for >10 seconds. Release push button when LED starts to blink. LED will blink in a 9-flash sequence. Each LED flash represents a 1-minute interval of delay for selection.
- Select delay value by pressing push button **AFTER** the desired blinks (1 blink represents 1 minute of delay).
- Release push button when LED begins to flash the confirmation sequence (repeats the selection of blinks).
- The number of LED blinks will represent the delay value entered for confirmation .

EXAMPLE: If push button is pressed after 6 flashes of the LED, this equates to a 6-minute delay time. LED will then flash 6X to confirm the delay value entered was 6 minutes.

ACCEPT SELECTION:

1X (1) To accept the value, press and hold the push button until the LED flashes 2 times, then release push button. This exits the delay programming mode and new delay value is stored. Timer mode is restored for operation.

10X (10-90 Minutes)

To accept the value, press and hold the push button beyond when the LED flashes 2 times, continue holding the push button until the LED blinks continuously at a fast rate. Then release. This exits the delay programming mode and new 10X delay value is stored. Timer mode is restored for operation.

ABORTING TIME DELAY VALUE:

During programming, if the push button is not pressed again during any steps in the programming sequence (or loss of power during programming) the program will abort & resume using the previous stored delay value in memory (factory default 3-minutes) No new data will be stored unless the user confirms by entering / storing the values using the push button.

The 9-blink LED sequence will repeat 5X. If no selection is made during the 9-blink sequence, the program will abort and revert back to the previous stored delay value from memory . This allows the user to ignore a changed value or enter a new value.

** NOTE: If you do not continue with programming at any time during the sequence, the module will default back to the previous delay setting from memory after a few minutes or if power is removed during the procedure.*

BATTERY SAVER MODE

Battery Saver Mode is a function that enables the accessory output to remain ON after engine is turned OFF. The timer function is removed and module will automatically monitor the battery charge level, automatically turning output OFF if battery level falls below a predetermined safe voltage level (approximately ~11.5VDC).

This function is used for extended operation of accessory components without the fear of having a dead battery when required to re-start engine.

*** NOTE: Battery Saver mode is also operational during TIMER mode as a convenience feature*

CHANGING MODES BATTERY SAVER/TIMER MODE

STATUS:

Engine OFF, Module powered = OFF, LED=OFF, fuse not illuminated.

BATTERY SAVER MODE SETTING:

- With engine OFF, press and hold down push button
- While holding push button, start vehicle engine. Continue to hold push button until 2 LED blinks are observed, then release push button to enter Battery Saver mode.

LED will remain ON once Battery-Saver mode is activated. LED will blink twice every 10 seconds, to indicate device is operating in BATTERY-SAVER MODE.

TIMER MODE SETTING: Repeat above steps to revert back to Timer mode

NOTE: Holding push-button during power-up will toggle between Battery-Saver Mode or TIMER Mode. LED status will indicate the mode currently operating.

TIMER DISABLE MODE

The TIMER function delay can be disabled to eliminate the delay. The accessory output will respond directly to engine run / stop when delay is disabled.

PROGRAMMING TIME DELAY DISABLE MODE

STATUS:

Engine running, Module powered = ON, LED=ON, fuse illuminated

TIMER DELAY DISABLE:

- With the engine running, press & hold push button 20 LED blinks (~20 seconds).
- Release push button when LED stops blinking and remains ON.

Timer delay function is disabled.

Time delay can be re-programmed by entering a 1-minute to 90 minute delay value by following the PROGRAMMING TIMER MODE procedure.

NOTES

** If you do not continue with programming at any time during the sequence, the module will default back to the previous delay setting from memory after a few minutes or if power is removed during the procedure.*

*** NOTE: Battery Saver mode is also functional in the background during TIMER mode as a convenience feature*

**** Any mode selection is retained during power loss or until changed by user.*

Optional Single Relay Install

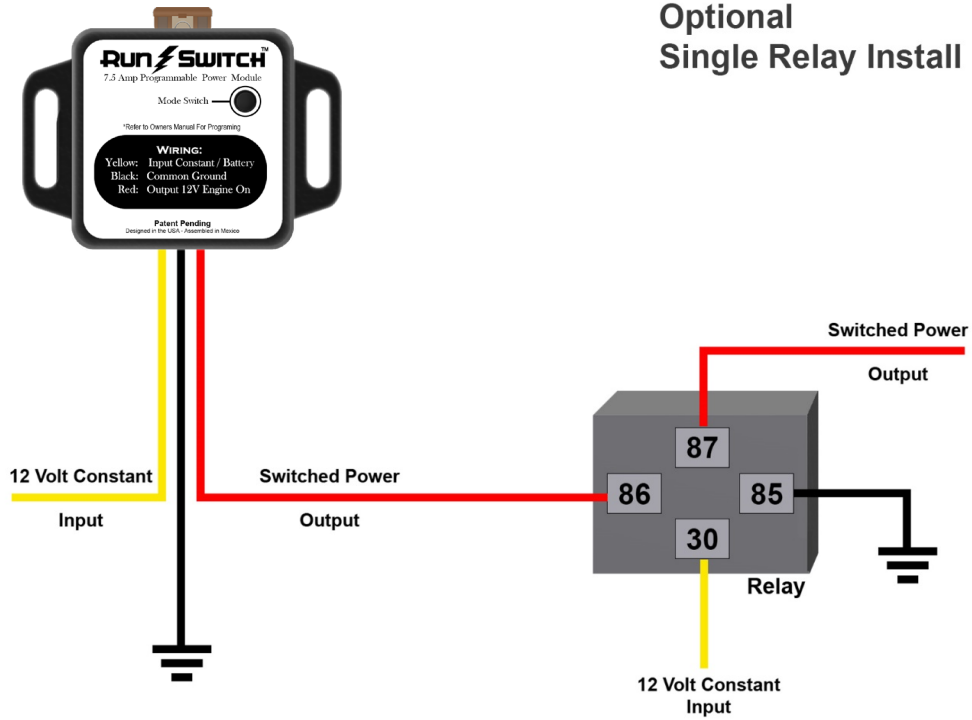

Optional Multiple Relay Install

