

AIMS POWER™

www.aimscorp.net

DC TO AC PURE SINE POWER INVERTER WITH CHARGER & TRANSFER SWITCH

PIC100012120S



INSTRUCTION MANUAL

A. INTRODUCTION

The AIMS Power pure sine inverter product line is used for back-up power. The pure sine product line is ideal for sensitive equipment and provides clean power, which is more efficient for back-up power applications. The power inverter transforms DC (direct current) electricity into AC (alternating current) power that can be used for running a wide variety of tools and appliances. This inverter is perfect for providing mobile power in cars, RVs, boats and work trucks. Using the built in charger and transfer switch, the inverter can also be utilized as a back-up power source in the event of an electrical failure or for applications that transfer from grid to inverter power frequently.

Please read this instruction manual carefully and make sure your inverter is installed properly before using.

B. WARNING AND SAFETY

1. Read the manual before connecting this inverter and keep it for future reference.
2. Do not put the inverter under direct sunlight or near a heating source.
3. The case of the inverter will get hot when used. Do not allow flammable materials to contact the inverter, such as clothing, sleeping bags, carpet or any other flammable materials. The heat from the inverter can damage these items.
4. The power inverter is designed to be used with a negative ground electrical system! Don't use with positive ground electrical systems (the majority of modern automobiles, RVs, trucks and boats are negative ground).
5. Do not disassemble the unit: it may cause fire or electric shock.
6. This device should only be serviced by a qualified technician. This item does not have any serviceable parts.
7. Prevent body contact with grounded surfaces such as pipes, radiators, ranges, and refrigerator enclosures during installation.
8. Do not operate the inverter if under the influence of alcohol or drugs. Read warning labels on prescriptions to determine if your judgement or reflexes are impaired while taking drugs. If there is any doubt, do not operate the inverter.
9. People with pacemakers should consult their physician(s) before using this product. Electromagnetic fields in close proximity to a pacemaker could cause interference to or failure of the pacemaker.
10. Keep the inverter well-ventilated. Do not place any objects on top of or next to the inverter or allow anything to cover the cooling fans; doing so can cause the inverter to overheat, causing a potential fire hazard and/or damage to the inverter. Leave adequate ventilation space underneath the inverter as well; thick carpets or rugs can obstruct air flow, causing the inverter to overheat.
11. Avoid unintentional starting. Be sure the switch is in the OFF position when not in use and before plugging in any appliance.
12. Keep inverter away from children. Don't install the inverter where it is accessible to children.
13. Disconnect the battery and inverter when not in use.

Note: Performance of this unit may vary depending on the available battery power or appliance wattage.

Warning: The warnings, cautions, and instructions discussed in this instruction manual cannot cover all possible conditions and situations that may occur. It must be understood by the operator that common sense and caution are factors which cannot be built into this product, but must be supplied by operator. Guard against electric shock. Do not open the metal case; risk of electric shock.



C. INVERTER FEATURES

- Hardwire AC terminal
- Built in charger 25/55 amp
- Automatic 15 amp transfer switch
- LED protect indicator
- LED power indicator
- Easy push on/off switch
- Remote port for on/off remote switch (optional part # REMOTEHF)
- Thermally controlled cooling fan
- Low battery voltage warning/shutdown
- High input voltage protection with automatic shutdown
- Over load indicator
- Short circuit protection
- AC output short circuit protection

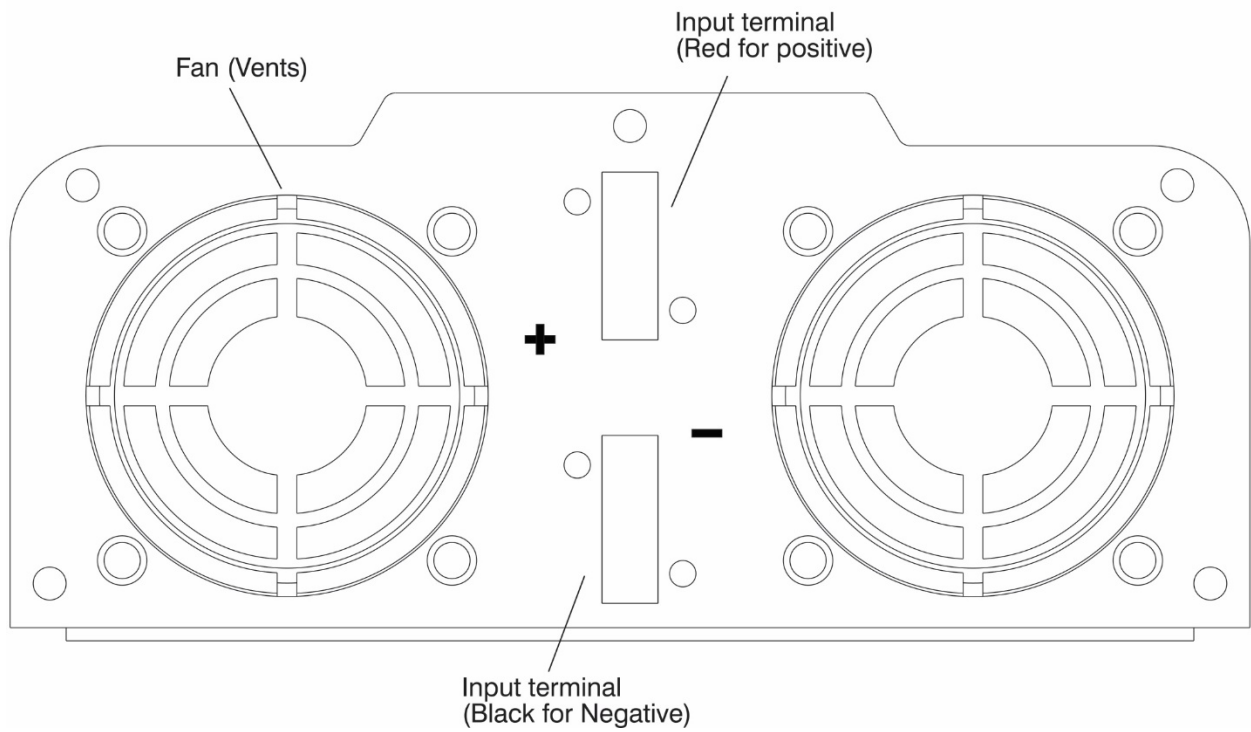
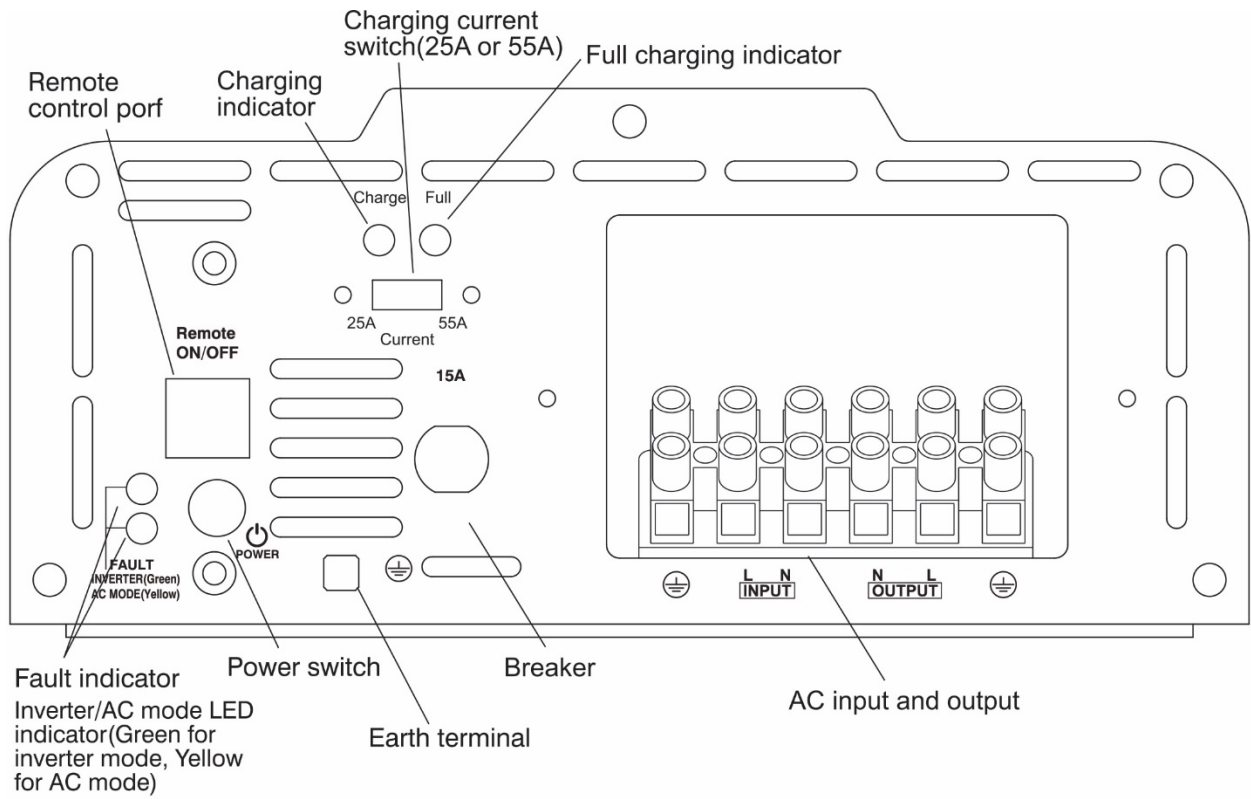

D. INSTALLATION

Ensure there is enough space for the installation, and the location should meet the following requirements:

1. Water should not access the inverter.
2. The ambient temperature should be 32~104°F, and the preferred temperature is 50-77°F. The lower the better in this range of ambient temperature.
3. Do not mount the inverter upside down.
4. We recommend mounting the inverter on something stable to prevent it from bouncing. Impact shock could result in damage to your unit. Be sure to use all four mounting screws for optimal stability. Mount in a location that can support the weight of the inverter.
5. Allow 12 inches of space around the inverter to prevent objects from blocking the vents and to provide enough air to circulate.
6. Do not install the inverter in an environment with high dust, saw dust residue or other particles that may get sucked into the inverter increasing internal temperature.
7. There will be some electrical arcing or spark when the inverter connects with the battery. Combustible materials such as gasoline, alcohol, etc. should not be around the inverter.

E. BATTERY

1. The battery is designed to supply the inverter with DC input voltage and the rated voltage should be in accordance with the rated input voltage of the inverter. Any voltage exceeding the range of the input voltage of the inverter will cause the inverter to go into overload and could possibly damage the inverter. The battery should supply enough current for the load. The load is the amp or watt rating of the equipment being powered by the inverter. A small capacity battery cannot provide enough power for large electrical equipment. In this case, the battery will cause the inverter to go into under voltage protection because of the load put on the battery. A simple way to calculate the load or amps required from your battery is to divide watts of equipment by battery voltage. Due to the consumption of the inverter itself, the actual current will be about 10% more. For example, the voltage of lead acid battery is 12VDC, and load of the equipment is 1000W, therefore, the actual current needed from the battery is about $1000W / 12V = 83.3$ amps per hour. Add 10% for efficiency loss and you get $83.3 * 1.10 = 91.6$ amp per hour needed. If you don't know the wattage of your equipment, you can figure the wattage by multiplying AC amps by AC voltage. For example, a refrigerator is 8 AC amps * 120 Volts AC = 960 watts. Remember, all equipment has a start-up requirement 3-5x its running wattage. In this example, $960 \text{ watts} * 3 = 2880$ watts needed from the inverter so don't size your inverter too small.

2. Battery operating time depends on battery capacity and load. The formula for operating time is: battery capacity divided by the value of the load divided by battery voltage times 1.10%. For example, using the numbers from above, the battery specification is 12V, 200Ah capacity and the load is 1000W. Take battery capacity 200Ah / 91.6 amps = 2.18 hours of run time if you fully deplete the battery. This is NOT recommended. Deep cycle batteries last longer when they are only depleted to 50% of capacity.

F. CONNECTION

1. Grounding

The power inverter has a terminal on the rear panel marked " Grounding "or "≡". This is used to connect the chassis of the power inverter to ground. The ground terminal has already been connected to the ground wire of the AC terminal through the inverter.

The ground terminal must be connected to the ground wire, which will vary depending on where the power inverter is installed. In a vehicle, connect the ground terminal to the chassis of the vehicle. In a boat, connect it to the boat's ground system. In a fixed location, connect the ground terminal to earth.

2. Battery terminals

Before you connect the battery cables, make sure the power switch is in the off position. Connect Red (+) battery cable to Red (+) inverter terminal. Connect Black (-) battery cable to Black (-) inverter terminal. Connect Red (+) battery cable to Red (+) battery terminal. Connect Black (-) battery cable to Black (-) battery terminal. Alligator clamp cables may be used but only to connect to the battery. Do not use clamps on inverter terminals. Alligator clamps are not a permanent solution. You may see a spark during connection. **Do not reverse the polarity.** This may damage the inverter and void warranty.

3. Hardwire Connection – AC Wiring. Use 12 AWG wire, fine copper stranded.

Input: Hot line + Neutral + Ground

Output: Hot line + Neutral + Ground

Green – ground

White – neutral

Black - hot

4. If connecting to a breaker panel do NOT neutral ground bond the panel.

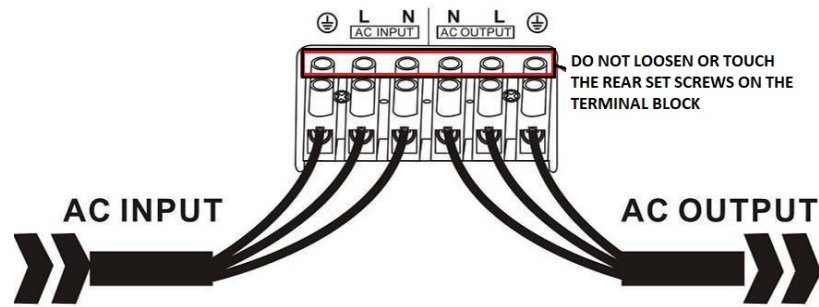

Do not loosen or touch the rear set screws on the terminal block.

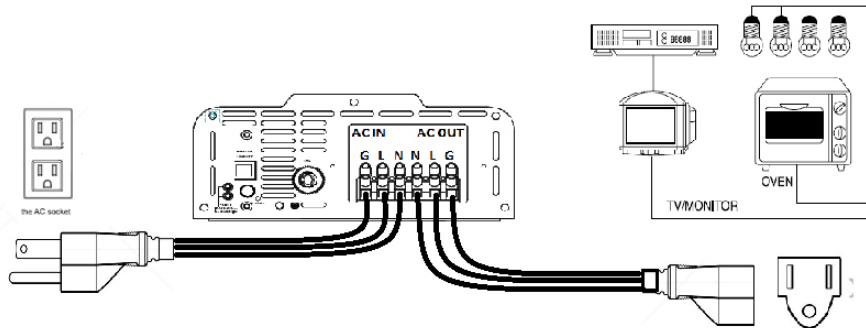

WARNING

The output voltage of this unit must never be connected in its input AC terminal, overload or damage may result. Always press power button to ON position before plugging in any appliance.

USING THE POWER INVERTER

1. Check the output voltage and capacity of the battery. The battery (s) should match the voltage of the inverter and have enough capacity for the load. See Section E for more information.
2. Connect your inverter to your battery bank and do not to reverse the polarities of the connection. See Section F.
3. Press the power switch button on your inverter for .5 seconds and a green LED will light up indicating that the inverter is on.
4. Before plugging anything into your inverter, make sure the appliance you are trying to power is shut OFF, then plug it into the AC outlet of your inverter and power on your appliance.
4. Once finished using the inverter, turn off your electrical appliance and the inverter. The indicator lights should be off.

5. The cooling fans inside the inverter do not work until the case temperature reaches approximately 104°F.
6. If you do not plan to use the inverter for a long period of time, disconnect it from your battery bank. Leaving the inverter on and connected for long periods of time may harm the equipment and over discharge the battery.

SOFT START TECHNOLOGY

The soft start technology built into this inverter protects the unit from delivering too much AC power at once by gradually increasing the AC voltage pushed out. To make sure that you are utilizing this feature, turn on the appliance being used before turning on the inverter. This is especially necessary for equipment that has an inductive load or electrical motor.

OUTPUT VOLTAGE & WAVEFORM

The electrical waveform output of this inverter is a pure sine wave, which has the same quality as utility and/or domestic power. This type of waveform is suitable for most electrical devices, appliances and tools. This pure sine wave unit provides more capabilities than modified sine wave inverters because it is a cleaner form of power. The pure sine wave also effectively reduces the noise produced while using appliances.

PROTECTIONS IN THE INVERTER

1. Input under-voltage alarm: When the input DC voltage is lower than 9.8V, the buzzer will whistle intermittently to remind that the inverter will go into the under voltage protection.
2. Under voltage protection: The inverter will automatically shut down when the input DC voltage is lower than 9.5V. The buzzer will whistle continuously and the green light is off, red light is on. Please turn off the inverter and use it after recharging the battery.
3. Over voltage protection: The inverter will automatically shut down when the input DC voltage is higher than 16V. The buzzer will whistle continuously and the green light is off, red light is on. Please turn off the inverter and adjust the input voltage to the admissible range.
4. Overload protection: The inverter will automatically shut down when the load is higher than the rated power. The buzzer will whistle continuously. Turn off the inverter and resume to normal operation after taking away the excessive load.
5. Short-circuit protection: The AC output will be automatically shut down when short circuited. It will automatically reset after the problem is solved.
6. Thermal protection: The unit will get hot during operation. If the temperature is higher than 149°F, the inverter will automatically shut down. Then the buzzer

will whistle continuously and the green light is off, red light is on. Please turn off the inverter, and continue using it after the temperature goes back to normal naturally. Meanwhile find out the factors causing the fault, such as ventilation, ambient temperature, vent, load power etc. It can avoid similar things from happening again.

****NOTE**** When the inverter is in the OFF position, the inverter doesn't consume battery current.

HI-POT TESTING OF DC to AC Inverter

Most of our AC inverters are Hi-Pot test and can pass a High Voltage Dielectric Withstand Test. The voltage applied to the control is usually equal to 1,000 volts, plus two times the line voltage rating of the inverter. Therefore, the standard hi-pot voltage for 115 VAC inverter is 1,250 VAC. For 230 VAC or dual voltage inverters, the hi-pot voltage is 1,500 VAC. This Aims power inverter is hi-pot tested before it leaves the factory. Hi-Pot testing is used to detect any electrical leakage between live metal components and the frame of the machine that is connected to earth ground. This helps prevent electrical shock to the user of the equipment should a live component touch the frame and the user touch the frame and ground at the same time.

TROUBLESHOOTING TIPS

Fault / Display	Cause	Solutions
No output voltage, buzzer sounds continuously	Low input DC voltage	Recharge or replace the battery
		Do not use it when the battery is charging. Check the rated voltage of the battery and make sure it is in within the range of the rated input voltage.
	High input DC voltage	
	Overload	Reduce the load.
	Over temperature	Cut off the load and let cool for 10 to 30 minutes. Restart after it returns to normal temperature. If the load is too large, reduce the total load to the range of inverter's rated power. Avoid blocking the vent and improve the ventilation surroundings. Reduce the ambient temperature.
No output voltage	The switch is off	Turn on the power switch.
	Poor cable connection	Check the cables and make sure they are tightly connected and in good condition.
Incorrect output voltage	RMS Multimeter measurement error	Use a true RMS multimeter to measure, such as model FLUKE 177/179.
	The battery power of RMS Multimeter is low.	Maintain the input voltage within the range of rated power. The input voltage is too high or too low.
		Change the battery of the multimeter then test again.
Cannot drive the load	Load is too large, or the actual power of the appliance exceeds nominal power.	Reduce the load, or turn on the appliance first, then turn on the inverter.
	The starting power is larger than rated power (such as motor).	The internal inverter soft-start circuit will buffer starting the appliance.

SPECIFICATIONS

MODEL NUMBER	PIC100012120S
DC Input Voltage	12V (9.8-16V)
Output Wave Form	Pure Sine
Output Power	1000W
Surge Power Capacity	2000W for 40 milsec
THD	<3%
Efficiency	>90%
No Load Current	1 amp switch on
Battery Low Alarm	DC 9.8 ± 0.3V
Battery Low Shutdown	DC 9.5 ± 0.5V
Input Over Voltage Shutdown	16 ± 0.5VDC
Operating Temperature (automatic recovery/shutdown)	32-113°F
Over Temperature Protection	149°F ± 8°F
Fan	Thermal based
Marine Protecton	Conformal coated to protect against moisture and corrosion
Charger	25A or 55A selectable 14.4V bulk, 13.5V float
Breaker	15 amps
Transfer/bypass	10 amps
Inline DC Fuse	100 amp recommended
Storage	Keep away from water and direct sunlight
Remote Switch Port	Yes- optional part # REMOTEHF
Recommended DC Cable Size	6 AWG or larger
Mouting Hole Location	11 1/2" center hole to center hold on length side
Cables Included	No
Dimensions (LxWxH)	17.5" x 9.5" x 3.8"
Inverter Weight	12 lb

WARRANTY

This product is designed using the most modern digital technology and under very strict quality control and testing guidelines. If, however, you feel this product is not performing as it should, please contact us: techsupport@aimscorp.net or (775)359-6703.

We will do our best to resolve your concerns. If the product needs repair or replacement, make sure to keep your receipt/invoice, as that will need to be sent back along with the package and RMA# prepaid to AIMS. You have a full 1 year warranty from date of purchase.

This warranty is valid worldwide with the exception that freight and duty charges incurred outside the contiguous 48 United States will be prepaid by customer.

Except as noted above, AIMS makes no warranty of any kind, express or implied, including without limitation the implied warranties of merchantability and fitness for a particular purpose. In no event shall AIMS be liable for indirect, special or consequential damages. This warranty only applies to AIMS Power branded products. All other name brand products are warranted by and according to their respective manufacturer. Please do not attempt to return non-AIMS Power branded products to AIMS Power.

The following situations will void warranty:

1. The box is distorted, damaged or changed, and interior parts damaged because of an exterior hit or drop not reported at time of delivery.
2. Connect the DC power incorrectly reversing the polarity.
3. Dismantled or repaired the unit by an unauthorized person.
4. The unit was damaged by incorrect installation or operating method.

For additional products, please visit our web site: www.aimscorp.net

- Modified sine wave inverters
- Pure sine wave inverters
- Low Frequency Inverters
- Solar Charge Controllers
- Inverter Chargers
- Converters DC-DC
- Custom cut cables
- Batteries
- Solar Panels & Racks

To find out where to buy any of our products, you may also e-mail: sales@aimscorp.net or call (775)359-6703.