

KEEP FOR FUTURE REFERENCE

# OPERATING INSTRUCTIONS



908 W. Main • P.O. Box 368  
Laurel, MT USA 59044  
800-548-7341 (phone)  
406-628-8231 (phone)  
406-628-8354 (fax)  
[www.WPG.com](http://www.WPG.com)

 **INTENDED FOR USE BY SKILLED  
PROFESSIONALS • READ AND  
UNDERSTAND BEFORE OPERATING**

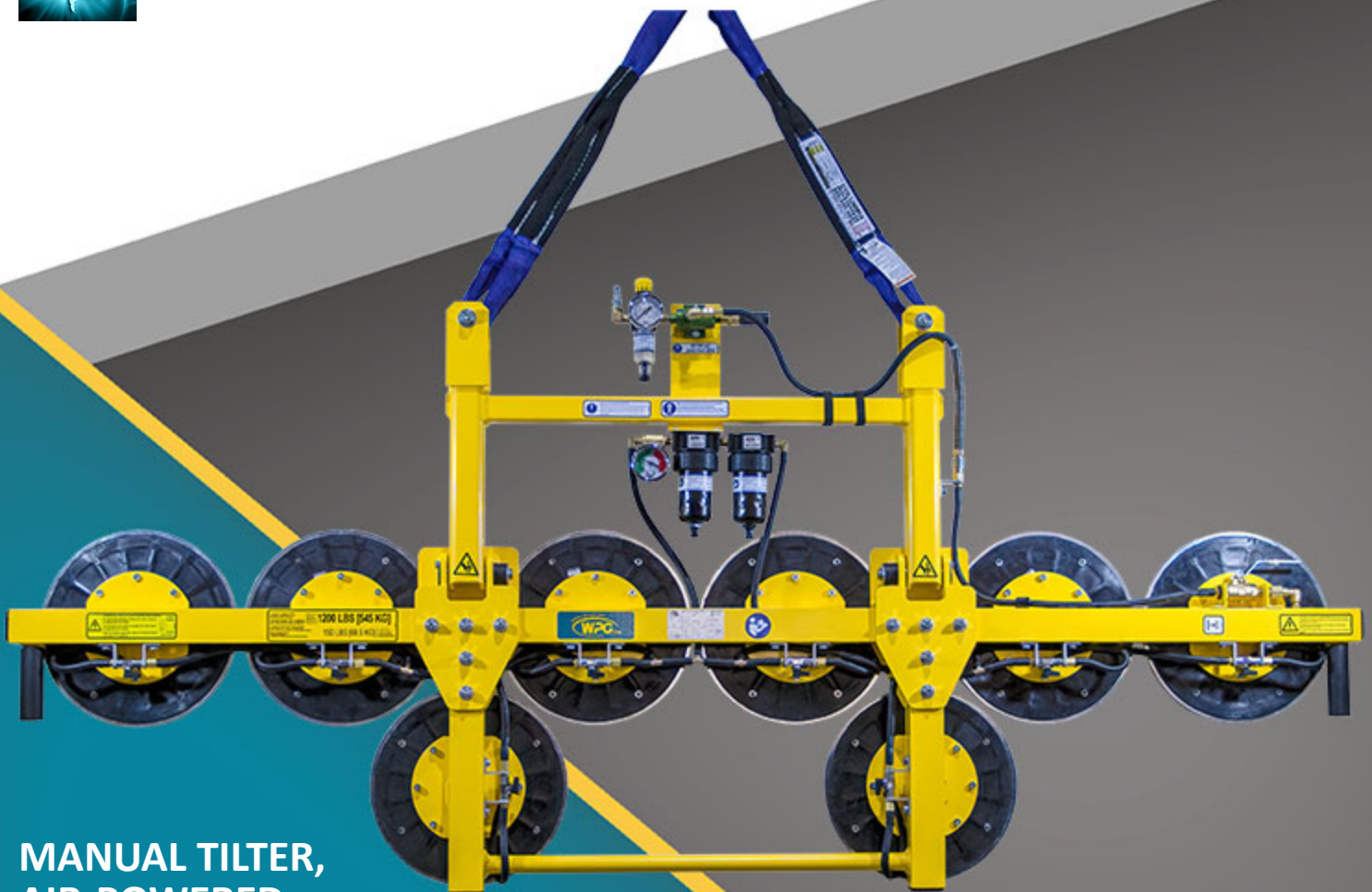

**MANUAL FILTER,  
AIR-POWERED**

Model numbers: MT410TAIR, MT610TAIR,  
MT810TAIR (shown), MT1010TAIR

Record serial number in blank space above (to locate, see serial label on the product).









# TABLE OF CONTENTS

<b>SPECIFICATIONS</b> .....	<b>3</b>
<b>SAFETY</b> .....	<b>5</b>
<b>OPERATING FEATURES</b> .....	<b>6</b>
<b>ASSEMBLY</b> .....	<b>7</b>
<b>INTENDED USE</b> .....	<b>9</b>
LOAD CHARACTERISTICS.....	9
OPERATING ENVIRONMENT .....	10
DISPOSAL OF THE LIFTER .....	10
<b>OPERATION</b> .....	<b>11</b>
<b>BEFORE USING THE LIFTER</b> .....	<b>11</b>
Taking Safety Precautions .....	11
Performing Inspections and Tests .....	11
<b>TO USE THE PAD SHUTOFFS</b> .....	<b>12</b>
<b>TO ATTACH THE PADS TO A LOAD</b> .....	<b>13</b>
Positioning the Lifter on the Load.....	13
Sealing the Pads on the Load .....	14
Reading the Vacuum Gauge.....	14
<b>TO LIFT AND MOVE THE LOAD</b> .....	<b>15</b>
Interpreting the Vacuum Gauge .....	15
Monitoring the Vacuum Gauge.....	15
Controlling the Lifter and Load .....	15
In Case of a Power Failure.....	16
<b>TO TILT THE LOAD</b> .....	<b>17</b>
<b>TO LAND THE LOAD</b> .....	<b>17</b>
<b>TO RELEASE THE PADS FROM THE LOAD</b> .....	<b>18</b>
<b>AFTER USING THE LIFTER</b> .....	<b>18</b>
Storing the Lifter .....	18
Transporting the Lifter .....	18
<b>INSPECTIONS AND TESTS</b> .....	<b>19</b>
<b>INSPECTION SCHEDULE</b> .....	<b>19</b>
<b>TESTING</b> .....	<b>20</b>
Lifter/Load Compatibility Test.....	20

# TABLE OF CONTENTS

Operational Tests .....	21
Vacuum Test.....	21
Rated Load Test.....	22
<b>MAINTENANCE .....</b>	<b>23</b>
<b>VACUUM PAD MAINTENANCE.....</b>	<b>23</b>
Pad-to-Load Friction Coefficient .....	23
Pad Inspection .....	23
Pad Cleaning .....	24
<b>TO REPLACE SEALING RING IN VPFS10T PADS .....</b>	<b>25</b>
<b>REPLACEMENT PARTS.....</b>	<b>26</b>
<b>LIMITED WARRANTY .....</b>	<b>27</b>
<b>TO OBTAIN REPAIRS OR WARRANTY SERVICE.....</b>	<b>27</b>

# SPECIFICATIONS

<b>Product Description</b>	Designed for use with hoisting equipment, MT-10TAIR lifters support loads using vacuum and manipulate loads using manual 90° tilt motions.			
<b>Model Number</b>	MT410TAIR (4 vacuum pads)	MT610TAIR (6 vacuum pads)	MT810TAIR (8 vacuum pads)	M1010TAIR (10 vacuum pads)
<b>Maximum Pad Spread</b> (to outer edges)	11¾" x 53¾" [30 cm x 137 cm]	11¾" x 77¾" [30 cm x 197 cm]	21¼" x 77¾" [54 cm x 197 cm]	33¾" x 77¾" [85 cm x 197 cm]
 <b>Maximum Load Capacity</b> <sup>1</sup>	Per pad:150 lbs [68 kg] Total: 600 lbs [270 kg]	Per pad:150 lbs [68 kg] Total: 900 lbs [270 kg]	Per pad:150 lbs [68 kg] Total: 1200 lbs [270 kg]	Per pad:150 lbs [68 kg] Total: 1500 lbs [270 kg]
 <b>Lifter Weight</b>	90 lbs [41 kg]	105 lbs [48 kg]	115 lbs [53 kg]	130 lbs [59 kg]
<b>Vacuum Pads</b> (standard rubber <sup>2</sup> )	10" [25 cm] nominal diameter with replaceable sealing rings for rough or textured surfaces (Model VPFS10T).			
<b>Power Source</b>	Compressed air, 80-150 psi [550-1035 kPa] line pressure, 5 SCFM [142 liters/minute] @ 80 psi [550 kPa]			
 <b>Tilt Capability</b>	Manual, 90°			
 <b>Product Options</b>	<i>Available</i> with Center Spool Lift Bar. See separate instructions about other options.			
 <b>Operating Elevation</b>	Up to 6,000' [1,828 m]			
 <b>Operating Temperatures</b>	32° — 104° F [0° — 40° C]			
<b>Service Life</b>	20,000 lifting cycles, when used and maintained as intended <sup>3</sup>			
<b>ASME Standard BTH-1</b>	Design Category "B", Service Class "0"			
<b>Troubleshooting Guide</b> <sup>4</sup>	<a href="#">TST-016_GENERIC_LEAK_TEST_rev_2014-086</a>			

- 1..... The Maximum Load Capacity is rated at a vacuum of 16" Hg [-54 kPa] on clean, smooth, nonporous flat surfaces with a friction coefficient of 1. Pad compound, load rigidity, strength, surface conditions, overhang, angle, center of gravity and temperature can also affect the lifting capacity. A "qualified person" should evaluate the effective lifting capacity for each use (see definition under "Rated Load Test").
- 2..... Available with other rubber compounds for special purposes (see [www.wpg.com](http://www.wpg.com)).
- 3..... Vacuum pads, filter elements and other wear-out items are excluded.
- 4..... To view this guide, click the link above.

# SPECIFICATIONS

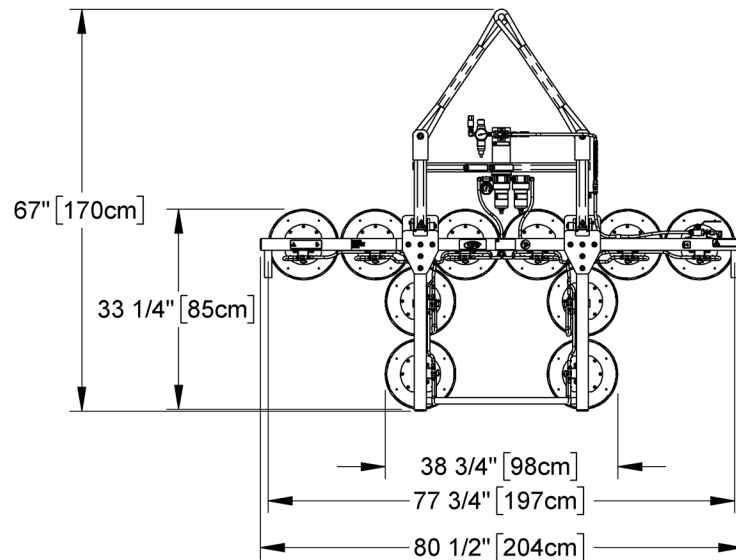
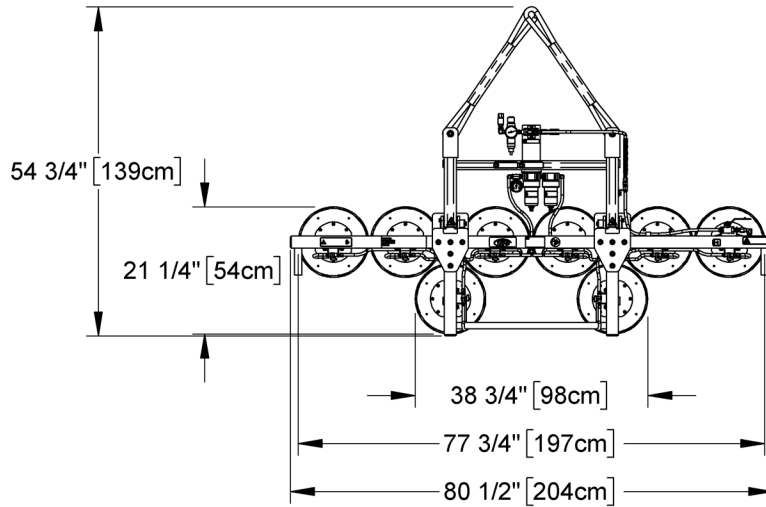
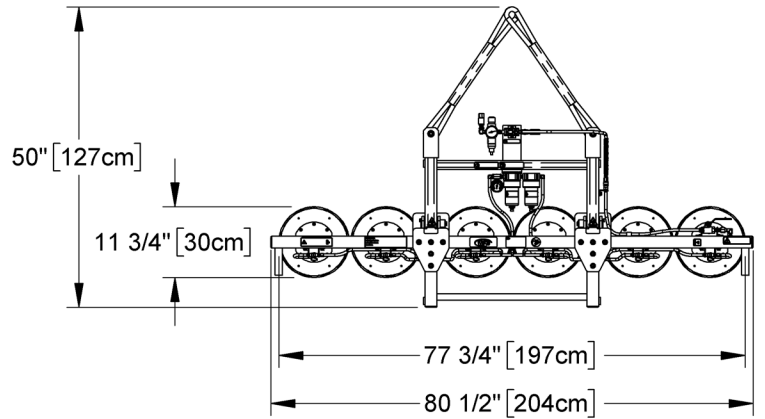
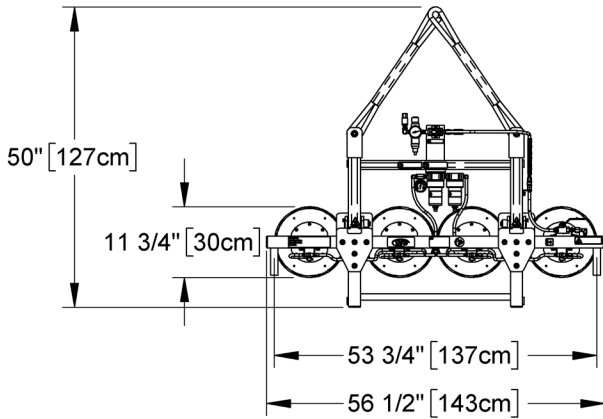

# SAFETY



Wear personal protective equipment that is appropriate for the load material. Follow trade association guidelines.



Do not remove or obscure safety labels.



Do not make any modifications to the lifter (see "LIMITED WARRANTY").



Use the lifter only in an approved "OPERATING ENVIRONMENT" (see "INTENDED USE").



Do not use a lifter that is damaged, malfunctioning, or missing parts.



Do not use a lifter if the sealing edge of any vacuum pad is cut or otherwise damaged.



Do not use a lifter to lift cracked or broken glass.



Do not exceed the Maximum Load Capacity or lift loads the lifter is not designed for (see "INTENDED USE").



Do not use a lifter if the Maximum Load Capacity or any safety label appears to be missing or obscured.



Make sure the contact surfaces of the load and vacuum pads are clean before attaching the lifter (see "MAINTENANCE").



Position the vacuum pads correctly on the load before lifting (see "OPERATION: Positioning the Lifter on the Load").



Do not lift a load if any vacuum indicator shows inadequate vacuum.



Keep unauthorized personnel away from the lifter, to avoid injury in case of an unintended load release.



Do not touch the vacuum release controls during a lift.



Do not allow people to ride on the lifter or the load.



Do not lift a load higher than necessary or leave suspended loads unattended.



Do not position a loaded or unloaded lifter over people.



Before servicing a powered lifter, place the power control in the inactive position and, when possible, disconnect the power source.

# OPERATING FEATURES

Features shown here are underlined> on their first appearance in each section following.

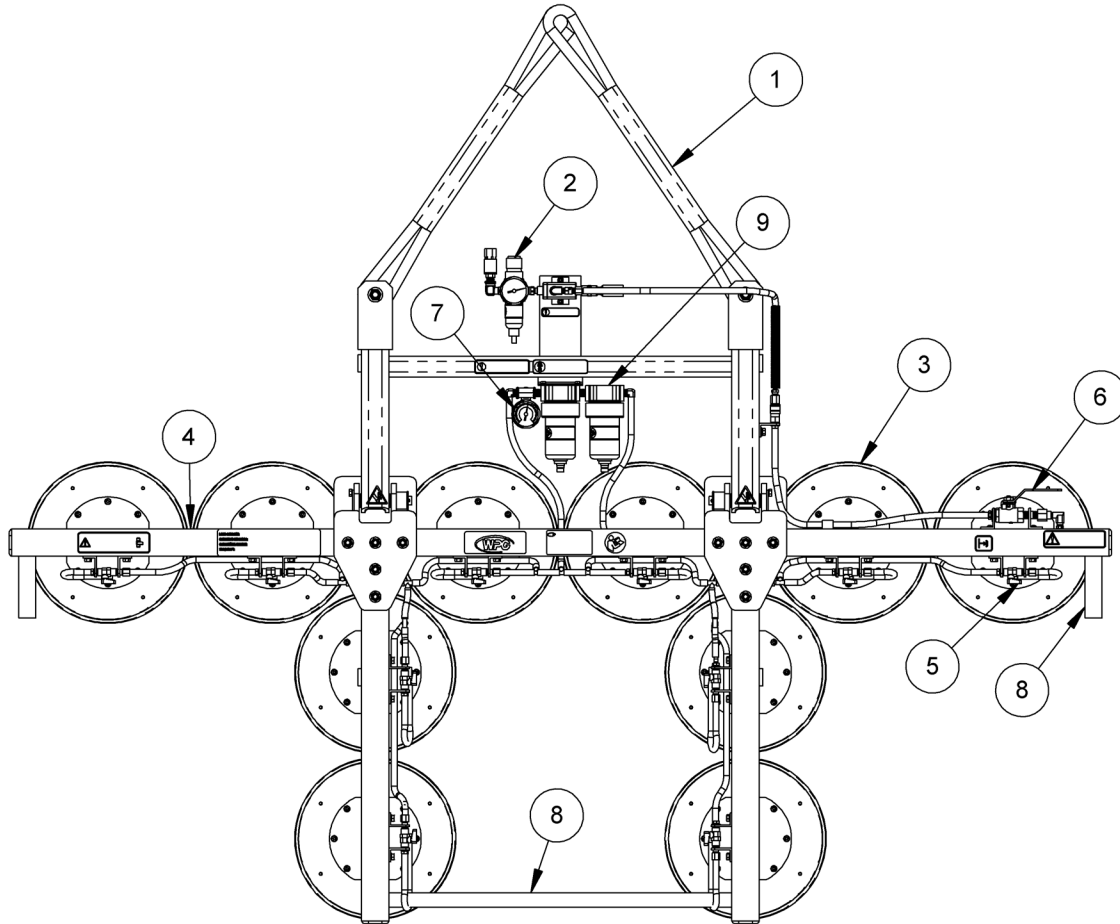

- |   |              |   |  |   |                      |
|---|--------------|---|--|---|----------------------|
| 1 | LIFT SLING   | 2 | AIR PRESSURE REGULATOR<br>and SMALL AIR FILTER | 3 | VACUUM PAD           |
| 4 | PAD FRAME    | 5 | PAD SHUTOFF                                    | 6 | VACUUM CONTROL VALVE |
| 7 | VACUUM GAUGE | 8 | CONTROL HANDLES                                | 9 | LARGE AIR FILTERS    |

*Note: A standard MT1010TAIR is shown. Although some of the following photos do not show this specific lifter, they all illustrate how this kind of lifter functions.*

For information about specific parts, see [“REPLACEMENT PARTS”](#) and/or any separate instructions for Product Options.



# ASSEMBLY

- 1) Remove all shipping materials and save them with the shipping container for future use.
- 2) Suspend the lifter from appropriate hoisting equipment:

2.1) Select a crane and/or hoist rated for the Maximum Load Capacity plus the Lifter Weight.

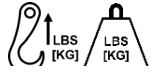

*Note: Any lifter use must comply with all statutory or regulatory standards for hoisting equipment in your region.*

2.2) Make sure the lift slings are securely attached to the lifter (fig. 2A).

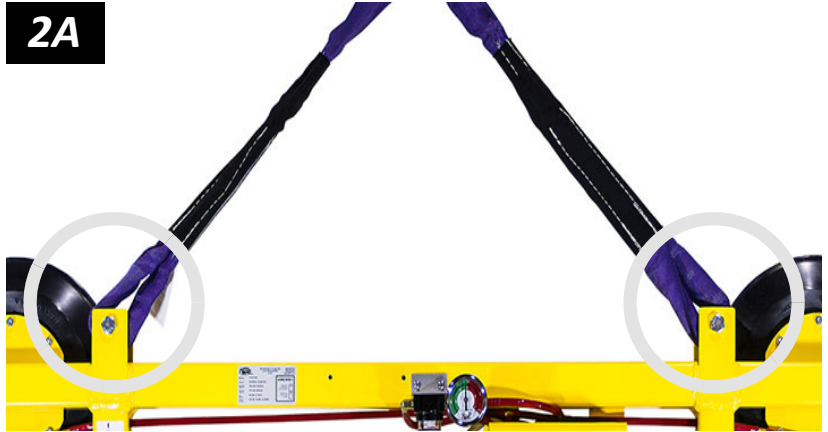

2.3) Attach the free eye of each lift sling to the hoisting equipment hook (fig. 2B).<sup>1</sup>



**Make sure hook has restraining latch (circled right).**

**2B**



*Note: A large clevis makes it easier to connect or disconnect the lift slings.*



**Only use clevis and clevis pin rated for Maximum Load Capacity plus Lifter Weight.**

2.4) Use the hoisting equipment to remove the lifter from the shipping container. Avoid damaging the vacuum pads.

2.5) Remove the pad covers (fig. 2C) and save them for future use.

**2C**



1..... If the lifter has a Center Spool Lift Bar, disregard the directions about lift slings. Instead, attach the hoisting equipment hook directly to the lift spool. All other directions and warnings still apply.

# ASSEMBLY

- 3) Connect the lifter to an appropriate compressed air supply (see Power Source under “SPECIFICATIONS”):

*Note: Qualified service personnel should install the female quick connector (supplied) on the compressed air line, when necessary.*

**Caution:** Make sure the air line is routed so that it does not become tangled or damaged during operation.

Connect the female quick connector to the male quick connector mounted adjacent to the air pressure regulator (fig. 3A).



- 4) Adjust the pressure regulator to supply 80 psi [550 kPa]:<sup>1</sup>

*Note: Vacuum pads must not be attached to any surface while adjusting the regulator.*

- 4.1) Place the vacuum control valve lever parallel with the vacuum line (ie, “attach” position — fig. 4A).

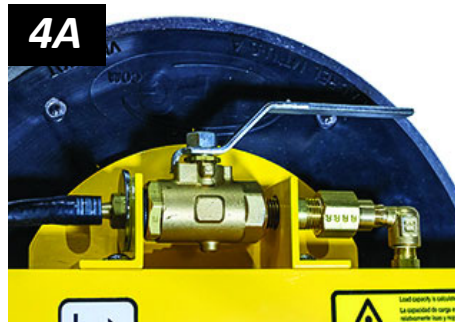

- 4.2) Pull up the adjustment collar on top of the regulator, and turn the collar clockwise to increase pressure or counter-clockwise to decrease pressure (fig. 4B).



- 4.3) When the pressure gauge registers a minimum air pressure of 80 psi [550 kPa], push down the collar to lock it in place.

- 4.4) Place the vacuum control valve lever perpendicular to the vacuum line (ie, “release” position — fig 4C).

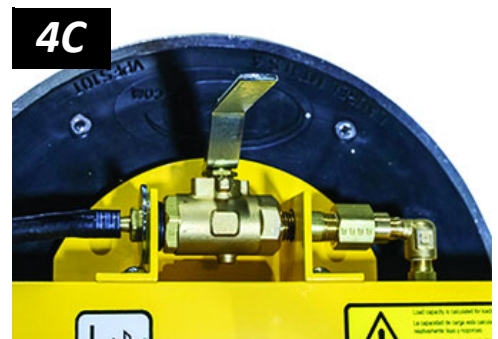

*Note: Disconnect the compressed air line when the lifter is not in use; otherwise, the air compressor will cycle frequently.*

- 5) Perform tests as required under “TESTING”.

<sup>1</sup>..... Exceeding this pressure consumes more air and does not improve lifter performance.

# ← INTENDED USE →

## LOAD CHARACTERISTICS

Make sure the vacuum lifter is intended to handle each load according to these requirements:



**Do NOT lift explosives, radioactive substances or other hazardous materials.**



- The load weight must not exceed the Maximum Load Capacity.
- The load must be a single piece of relatively nonporous material with a flat and relatively smooth contact surface.<sup>1, 2</sup> To determine whether the load is too porous or rough, perform the “[Lifter/Load Compatibility Test](#)”.
- The load's contact surface must be able to obtain a friction coefficient of 1 with the lifter's vacuum pads (see “[Pad-to-Load Friction Coefficient](#)”). Otherwise, the capacity should be derated appropriately.
- The load's surface temperature must not exceed the Operating Temperatures.<sup>3</sup>
- The load's *minimum* length and width are determined by the current Pad Spread (see “SPECIFICATIONS”).
- The load's *maximum* length and width are determined by its allowable overhang.<sup>4</sup>
- Although load thickness is not restricted, it may affect the lifter’s hang angle and the amount of operator effort required for handling loads.



*Note: Standard vacuum pads can stain or deform load surfaces with light colors or soft coatings. Test such surfaces for damaging effects before using the lifter on them.<sup>5</sup>*

---

1..... Although concave vacuum pads can also attach to some curved loads, curvature can reduce lifting capacity. Contact WPG for more information.

2..... A “single piece” of material includes curtainwall assemblies, unitized glazing systems and similar construction units.

3..... Vacuum pads made from a heat-resistant rubber compound can enable you to lift loads with higher surface temperatures. Contact WPG or an authorized dealer for more information.

4..... The allowable overhang is the amount of load material that can extend sideways beyond the vacuum pads without breaking or otherwise being damaged. This depends on the load material, its thickness, and the angle of handling (if any). Since every material has different physical properties, the allowable overhang must be evaluated separately for each load type. Contact WPG or an authorized dealer for more information.

5..... Alternative rubber compounds are available for these purposes. Contact WPG or an authorized dealer for more information.

# INTENDED USE

## OPERATING ENVIRONMENT

Make sure the vacuum lifter is intended for use in each work environment, given the following restrictions:

- This lifter is not intended for any environment that is dangerous to the operator or damaging to the lifter. Avoid environments containing explosives, caustic chemicals and other dangerous substances.
- The work environment is limited by the Operating Elevation and Operating Temperatures.<sup>1, 2</sup>
- The lifter is not designed to be watertight. Do not use it in rain or other unsuitable conditions.

 **Never use lifter in dangerous environments.**

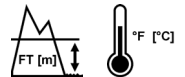

**Moisture can result in reduced lifting capacity.**

**CE/UKCA** — A secondary positive holding device is required to lift loads on construction sites.

## DISPOSAL OF THE LIFTER

After the Service Life of the vacuum lifter has ended (see “SPECIFICATIONS”), dispose of it in compliance with all local codes and applicable regulatory standards.

1..... Although lifter use may be possible at higher elevation, lifting capacity is reduced whenever the lifter is unable to attain vacuum in the green range on the vacuum gauge. Contact WPG for more information.

2..... Special provisions may allow the lifter to operate outside the specified temperature range. Contact WPG for more information.

## BEFORE USING THE LIFTER

Determine whether the vacuum lifter is capable of each intended task (see “SPECIFICATIONS” and “[INTENDED USE](#)”). Then complete the following preparations:

### Taking Safety Precautions

- Be trained in all industry and regulatory standards for lifter operation in your region.
- Follow trade association guidelines about precautions needed for each load material.



***Read all directions and safety rules before using lifter.***



***Always wear appropriate personal protective equipment.***

### Performing Inspections and Tests

- Follow the “[INSPECTION SCHEDULE](#)” and “[TESTING](#)”.
- Examine the [air filters](#) and perform service whenever their bowls contain liquid or other contaminants or their elements appear dirty (see “[AIR FILTER MAINTENANCE](#)” in [SERVICE MANUAL](#)).



***Examine air filters regularly and service when needed.***

## TO USE THE PAD SHUTOFFS

Each pad shutoff on the pad frame controls the vacuum line to the adjacent vacuum pad. Activating or deactivating the airflow at specific pads enables the lifter to handle loads with different weights and dimensions (see “SPECIFICATIONS”) or to avoid holes in the load surface.

To support the maximum load weight and larger load dimensions, all pads must be activated; for smaller weights and dimensions, some pads may be deactivated, **provided that the lifter still has sufficient capacity to support the load** (see “LOAD CHARACTERISTICS”).



**Closing any pad shutoff reduces lifting capacity.**

To activate a pad, open the shutoff valve (ie, place lever *parallel* with vacuum line — fig. 1A).



To deactivate a pad, close the shutoff valve (ie, place lever *perpendicular* to vacuum line — fig. 1B).



To calculate the lifting capacity when some pads are deactivated, consult the Per-Pad Load Capacity and multiply by the number of pads currently activated. Always activate pads in a symmetrical configuration and use as many pads as possible for each load being lifted, to maximize lifting capacity and to minimize load overhang.





# OPERATION

## To ATTACH THE PADS TO A LOAD

Make sure the contact surfaces of the load and vacuum pads are clean (see “[Pad Cleaning](#)”).



## Positioning the Lifter on the Load

- 1) Determine which will be the top edge of the load while lifting, and position the long row of vacuum pads near that edge (fig. 1A).

**1A**

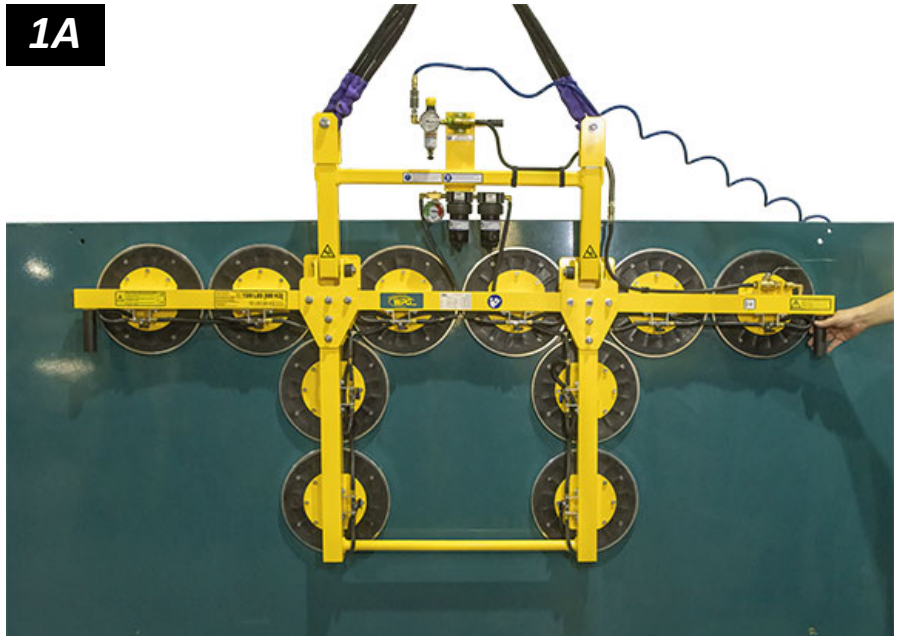

Make sure all activated pads will fit on the load and will be loaded evenly.



Consult the Per-Pad Load Capacity.

- 2) Center the pad frame from left to right on the load (fig. 2A).

**2A**



# OPERATION

## Sealing the Pads on the Load

- 1) Place the pads in contact with the load surface. Then place the vacuum control valve lever *parallel* with the vacuum line (ie, in the “attach” position — , fig. 2A).<sup>1</sup>



**Keep control valve in “attach” position throughout lift.**

**Caution:** Any interruption of airflow during lifter operation could cause a load release and personal injury.

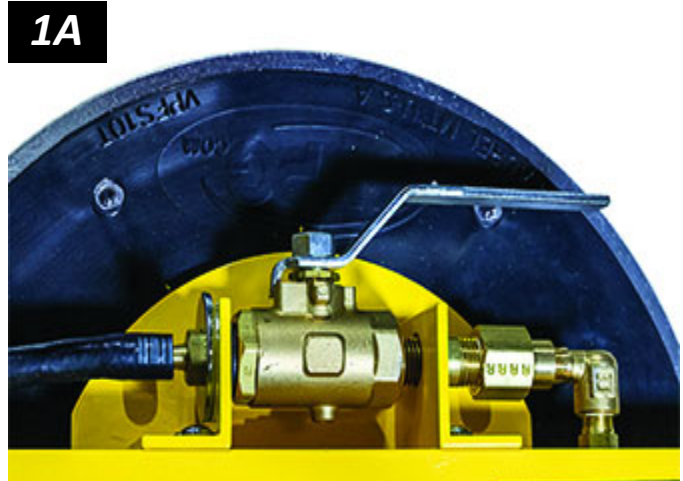

- 2) Press the lifter firmly against the load to help the pads begin to seal.<sup>2</sup>

## Reading the Vacuum Gauge

A vacuum gauge shows the current vacuum level in positive inches of Hg and negative kPa:

- **Green range** ( $\geq 16$ " Hg [-54 kPa]): Vacuum level is sufficient to lift the maximum load weight (fig. 1B).
- **Red range** ( $< 16$ " Hg [-54 kPa]): Vacuum level is **not** sufficient to lift the maximum load weight (fig. 1C).

**1B**



**1C**



If it takes more than 5 seconds for the vacuum level to reach 5" Hg [-17 kPa], press on any activated vacuum pad that has not yet sealed.

Once the pads have sealed, the lifter should be able to maintain sufficient vacuum for lifting, except when used above the maximum Operating Elevation.<sup>3</sup> If it does not, perform the “[Vacuum Test](#)”.

1..... Do not place the vacuum control valve in the “attach” position unless the vacuum pads are contacting the load.

2..... Although a vacuum pad may become distorted during shipping or storage, this condition should correct itself with continued use.

3..... If the lifter is used above the maximum Operating Elevation (see “SPECIFICATIONS”), it may not be able to maintain sufficient vacuum for lifting. Contact WPG for more information.



# OPERATION

## TO LIFT AND MOVE THE LOAD

### Interpreting the Vacuum Gauge

 Vacuum is sufficient to lift the Maximum Load Capacity whenever the vacuum gauge registers in the green range.

 **Never lift load unless vacuum gauge registers in the green range, because premature lifting could result in load release and personal injury.**

### Monitoring the Vacuum Gauge

Monitor the vacuum gauge (fig. 1B) throughout the entire lift.



 **Make sure the vacuum gauge remains completely visible.**

The vacuum pump runs continuously to maintain sufficient vacuum for lifting the maximum load weight.

However, if the **vacuum gauge shows a level less than 16" Hg [-54 kPa]:**

- 1) Keep everyone away from a suspended load until it can be safely lowered to a stable support.

 **Stay clear of any suspended load while gauge warns of low vacuum.**

- 2) Stop using the lifter until the cause of the vacuum loss can be identified: Conduct the “[Pad Inspection](#)” and perform the “[Vacuum Test](#)”.
- 3) Correct any faults before resuming normal operation of the lifter.

### Controlling the Lifter and Load

When the lifter is ready, use the hoisting equipment to raise the lifter and load as needed.

Use a control handle (circled in fig. 1A) to keep the lifter and load in the required position.

Once there is enough clearance, you may move the load as required.





***Never allow any pad shutoff to be opened or closed while lifting, because this could result in a load release and personal injury.***

## **In Case of a Power Failure**

Although the lifter is designed to support the load for at least 5 minutes without power, this depends on many factors, including the “[LOAD CHARACTERISTICS](#)” and the condition of the vacuum pads (see “[VACUUM PAD MAINTENANCE](#)”).

If a power failure occurs, keep everyone away from a suspended load until it can be safely lowered to a stable support. Correct any faults before resuming normal operation of the lifter.



***Stay clear of any suspended load during power failure.***

# OPERATION

## TO TILT THE LOAD

- 1) Make sure the load has enough clearance to tilt without contacting anyone or anything.
- 2) Tilt the load to the position needed:
  - Tilting the load to the *upright* position (fig. 1A) happens automatically when it is lifted.
  - Tilting the load to the *flat* position is accomplished during the landing (see section below).

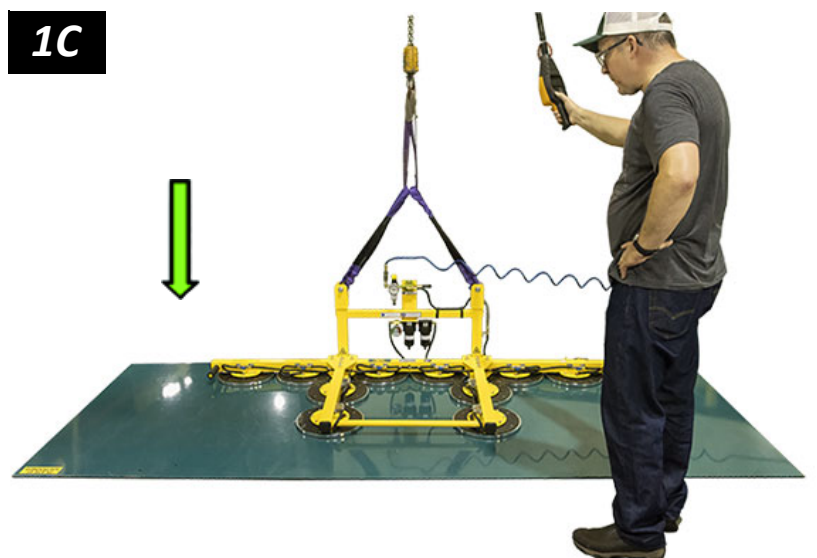
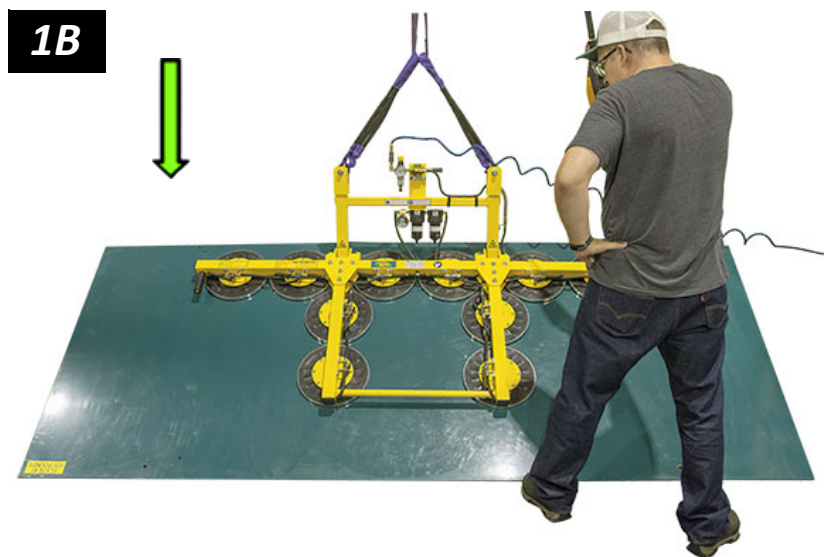
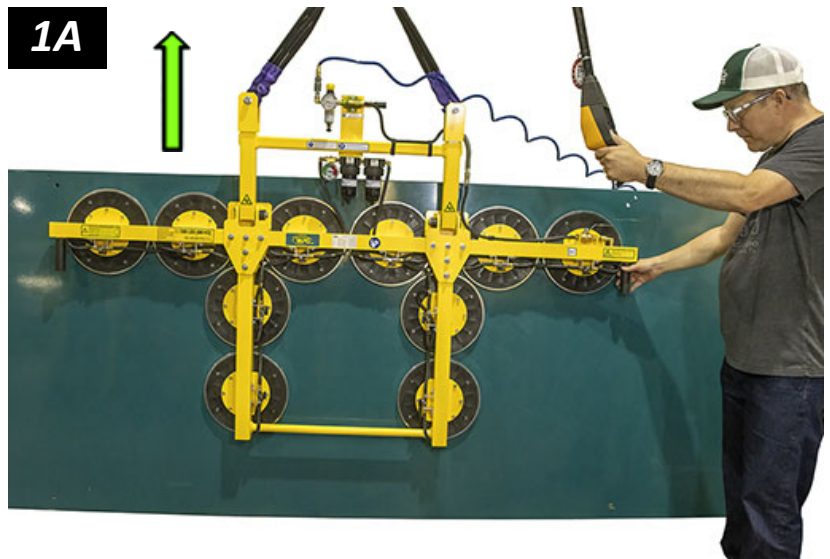

## TO LAND THE LOAD

- For a landing in the *upright* position, simply lower the load onto an appropriate support.
- For a landing in the *flat* position, lower the lifter until the bottom edge of the load is supported (fig. 1B).

Then carefully move the lifter forward, allowing the load to tilt while continuing to lower it (fig. 1C).

# OPERATION

## TO RELEASE THE PADS FROM THE LOAD



**Make sure load is at rest and fully supported before releasing vacuum pads.**



**Do not move lifter until pads release completely, because such movement could result in load damage or personal injury.**

- 1) Place the vacuum control valve lever *perpendicular* to the vacuum line (ie, “release” position — fig. 1A).
- 2) Before you lift another load, perform the Every-Lift Inspection (see “[INSPECTION SCHEDULE](#)”).

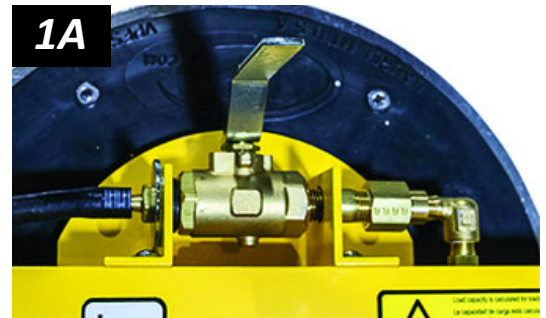

## AFTER USING THE LIFTER

- 1) Place the vacuum control valve lever in the “release” position (see above).
- 2) Use the hoisting equipment to lower the vacuum lifter gently onto a stable support. Then detach the hoisting hook from the lift slings.

**Caution:** Do not set lifter on surfaces that could soil or damage vacuum pads. Protect their sealing rings by making sure each pad rests on spacers.<sup>1</sup>

## Storing the Lifter

- 1) Disconnect the compressed air supply (see “[ASSEMBLY](#)”).
- 2) Use the covers supplied to keep the vacuum pads clean (fig. 1A).

**CE/UKCA** – To prevent the lifter from tipping over on relatively horizontal surfaces, place the vacuum pads facedown on a clean, smooth, flat surface.



## Transporting the Lifter

Secure the lifter in the original shipping container with the original shipping materials or equivalent.

1..... Cardboard spacers are integrated into the original shipping container. Similarly shaped spacers should be used when setting the lifter on other surfaces.

# INSPECTIONS AND TESTS

## INSPECTION SCHEDULE

Perform inspections according to the following frequency schedule. If any fault is found, correct it and perform the next most frequent inspection before using the vacuum lifter.

*Note: If a lifter is used less than 1 day in a 2-week period, perform the Periodic Inspection before using it.*

Action	Every Lift	Frequent <sup>1</sup> (every 20-40 hrs)	Periodic <sup>2</sup> (every 250-400 hrs)
Examine <u>vacuum pads</u> for contaminates or damage (see <a href="#">“Pad Inspection”</a> ).	✓	✓	✓
Examine load surface for contaminates or debris.	✓	✓	✓
Examine controls and indicators for damage.	✓	✓	✓
Examine lifter’s structure for damage.		✓	✓
Examine vacuum system for damage (including <u>vacuum pads</u> , fittings and hoses).		✓	✓
Examine <u>air filters</u> for conditions requiring service (see <a href="#">“AIR FILTER MAINTENANCE”</a> in <a href="#">SERVICE MANUAL</a> ).		✓	✓
Perform <a href="#">“Vacuum Test”</a> .		✓	✓
Check for unusual vibrations or noises while operating lifter.		✓	✓
Examine entire lifter for evidence of: <ul style="list-style-type: none"> <li>• looseness, excessive wear or excessive corrosion</li> <li>• deformation, cracks, dents to structural or functional components</li> <li>• cuts in vacuum pads or hoses</li> <li>• any other hazardous conditions</li> </ul>			✓

1..... The Frequent Inspection is also required whenever the lifter has been out of service for 1 month or more.

2..... The Periodic Inspection is also required whenever the lifter has been out of service for 1 year or more. Keep a written record of all Periodic Inspections. If necessary, return the lifter to WPG or an authorized dealer for repair (see [“LIMITED WARRANTY”](#)).

## TESTING

Perform the following test to determine whether or not a load surface is too porous or rough:

### Lifter/Load Compatibility Test<sup>1</sup>

- 1) Make sure the vacuum generating system is functioning correctly (see “[Vacuum Test](#)”).
- 2) Thoroughly clean the load surface and the vacuum pads (see “[Pad Cleaning](#)”).
- 3) Place the load in the upright position on a stable support.
- 4) Attach the vacuum pads to the load as previously directed.
- 5) After the vacuum level appears in the green range on the vacuum gauge, disconnect the compressed air supply (see “[ASSEMBLY](#)”).
- 6) Raise the load a minimal distance, to make sure it is supported by the lifter.
- 7) Watch the vacuum gauge: ***Starting from a vacuum level of 16" Hg [-54 kPa], the lifter must maintain a vacuum level greater than 12" Hg [-41 kPa] for 5 minutes.***<sup>2</sup> If not, lifting this load requires additional precautions (eg, a load sling). Contact WPG for more information.
- 8) Lower the load *after* 5 minutes or *before* the vacuum level diminishes to 12" Hg [-41 kPa].



***Take precautions in case load should fall during test.***

1..... The “[Pad-to-Load Friction Coefficient](#)” can affect the outcome of this test.

2..... Under CE and UKCA requirements, the lifter must maintain a vacuum level ***greater than 8" [-27 kPa]***.

# INSPECTIONS AND TESTS

Perform the following tests before placing the lifter in service *initially, following any repair*, when directed in the “*INSPECTION SCHEDULE*”, or *whenever necessary*:

## Operational Tests

Test all features and functions of the lifter (see “OPERATING FEATURES” and “OPERATION”).

## Vacuum Test

- 1) Clean the face of each vacuum pad (see “*Pad Cleaning*”).
- 2) Use a test load with weight equal to the Maximum Load Capacity, a clean, smooth, nonporous surface and other appropriate “*LOAD CHARACTERISTICS*”.<sup>1</sup>
- 3) Attach the lifter to the test load as previously directed.
- 4) After the vacuum level appears in the green range on the vacuum gauge, raise the load a minimal distance and disconnect the compressed air supply (see “*ASSEMBLY*”).
- 5) Watch the vacuum gauge: *The vacuum level should not decrease by more than 4" Hg [-14 kPa] in 5 minutes.*
- 6) Lower the load after 5 minutes or whenever a lifter fails the test, and release the load as previously directed.
- 7) Qualified service personnel must correct any fault in the vacuum system before the lifter can be returned to service.



**Take precautions in case load should fall during test.**



**Never use lifter that has failed test.**



**This service must be performed by qualified service personnel.**

1..... The load should have either a flat surface or no more curvature than the lifter is designed for, if any.



# INSPECTIONS AND TESTS

## Rated Load Test<sup>1</sup>

The following steps must be performed or supervised by a qualified person:<sup>2</sup>

- 1) Use a test load that weighs 125% ( $\pm 5\%$ ) of the Maximum Load Capacity and has the appropriate “LOAD CHARACTERISTICS”. 
- 2) Attach the vacuum pads to the load as previously directed.
- 3) Position the load to produce the greatest stress on the lifter consistent with “INTENDED USE”.
- 4) Raise the load a minimal distance and leave it suspended for 2 minutes.
- 5) Once the test is completed, lower the load for release as previously directed.
- 6) Inspect the lifter for any stress damage, and repair or replace components as necessary to successfully pass the test.
- 7) Prepare a written report of the test and keep it on file.



***Take precautions in case load should fall during test.***



***Never use lifter that has failed test.***

---

1..... An equivalent simulation may also be used. Contact WPG for more information.

2..... A “qualified person” has successfully demonstrated the ability to solve problems relating to the subject matter and work, either by possessing a recognized degree in an applicable field or a certificate of professional standing, or by possessing extensive knowledge, training and experience.



# MAINTENANCE

Note: Refer to **SERVICE MANUAL #36112** when applicable.

## VACUUM PAD MAINTENANCE

### Pad-to-Load Friction Coefficient

The friction coefficient represents the lifter's ability to resist load slippage. The Maximum Load Capacity assumes a friction coefficient of 1, based on testing of clean, new, standard rubber vacuum pads on clean, dry, regular glass. **If the lifter is used under other conditions, a qualified person must first determine the effective lifting capacity.**<sup>1</sup>

Long-term exposure to heat, chemicals or UV light can reduce the friction coefficient of vacuum pads. Replace pads and sealing rings or replaceable inserts every 2 years or more often when necessary.

### Pad Inspection

Inspect each vacuum pad (fig. 1A) according to the "INSPECTION SCHEDULE" and correct the following faults before using the lifter (see "REPLACEMENT PARTS", when applicable):

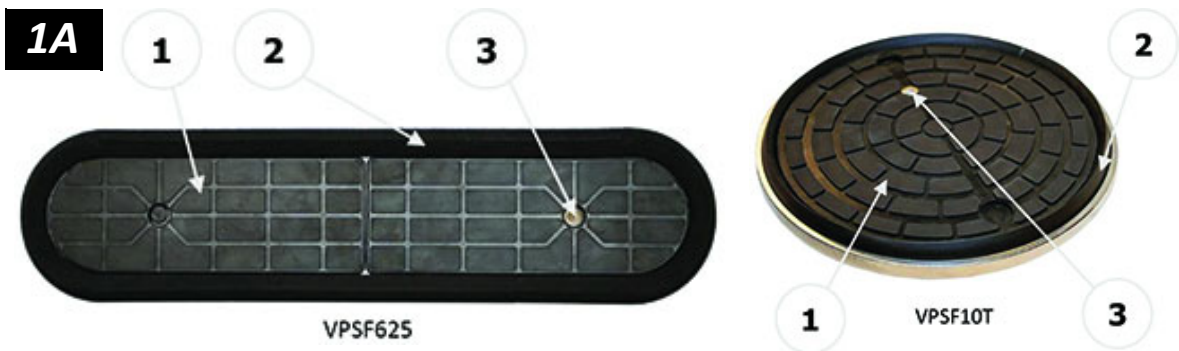

- Contaminates on the face (item 1 in fig. 1A) or sealing edges (item 2 in fig. 1A).
- Filter screen (item 3 in fig. 1A) missing from face.
- Nicks, cuts, deformation or abrasions in sealing edges.

**! Replace any sealing ring or pad insert that has damaged sealing edges (see "TO REPLACE SEALING RING IN VPFS10T PADS" or "TO REPLACE PAD INSERTS IN VPFS625 PADS", where applicable).**

1..... A "qualified person" has successfully demonstrated the ability to solve problems relating to the subject matter and work, either by possessing a recognized degree in an applicable field or a certificate of professional standing, or by possessing extensive knowledge, training and experience.

# MAINTENANCE

1A



## Pad Cleaning

- 1) Regularly clean the face of each vacuum pad (fig. 1A), using soapy water or other mild cleansers to remove oil, dust and other contaminants.

Solvents, petroleum-based products (including kerosene, gasoline and diesel fuel) or any other harsh chemicals can damage pads.



***Never use harsh chemicals on vacuum pad.***

Many rubber conditioners can leave a hazardous film on pads.



***Never use rubber conditioners on vacuum pad.***

- 2) Prevent liquid from entering the vacuum system through the suction hole on the pad face.
- 3) Wipe the pad face clean, using a clean sponge or lint-free cloth to apply the cleanser.<sup>1</sup>
- 4) Allow the pad to dry completely before using the lifter.

1..... A brush with bristles *that do not harm rubber* can help remove contaminants clinging to sealing edges. If these cleaning methods are not successful, contact WPG or an authorized dealer for assistance.

# MAINTENANCE

## TO REPLACE SEALING RING IN VPFS10T PADS

If the lifter has VPFS10T vacuum pads, replace sealing rings (#49724RT or #49724TT) as follows:

- 1) Remove the old sealing ring (fig. 1A).

*Note: Make sure the entire vacuum pad is clean, including the mounting groove.*

- 2) Place the inside edge of a new sealing ring against the inside edge of the mounting groove (fig. 2A).

- 3) Push the sealing ring into the mounting groove, beginning in 4 locations as shown circled in fig. 3A.

- 4) Push gently and firmly on the outside edge of the sealing ring until the flat side fits flush against the bottom of the mounting groove (fig. 4A). A pad ring installation tool (circled in fig. 4A) makes this step easier (see [“REPLACEMENT PARTS”](#)).

- 5) Make sure the sealing ring seats securely in the mounting groove, all the way around the vacuum pad (fig. 5A).

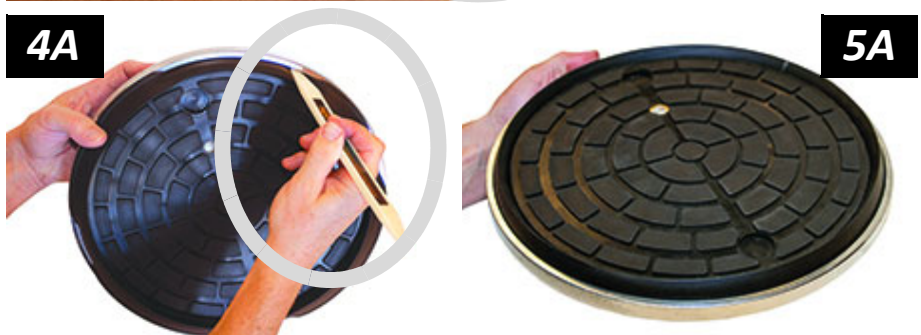
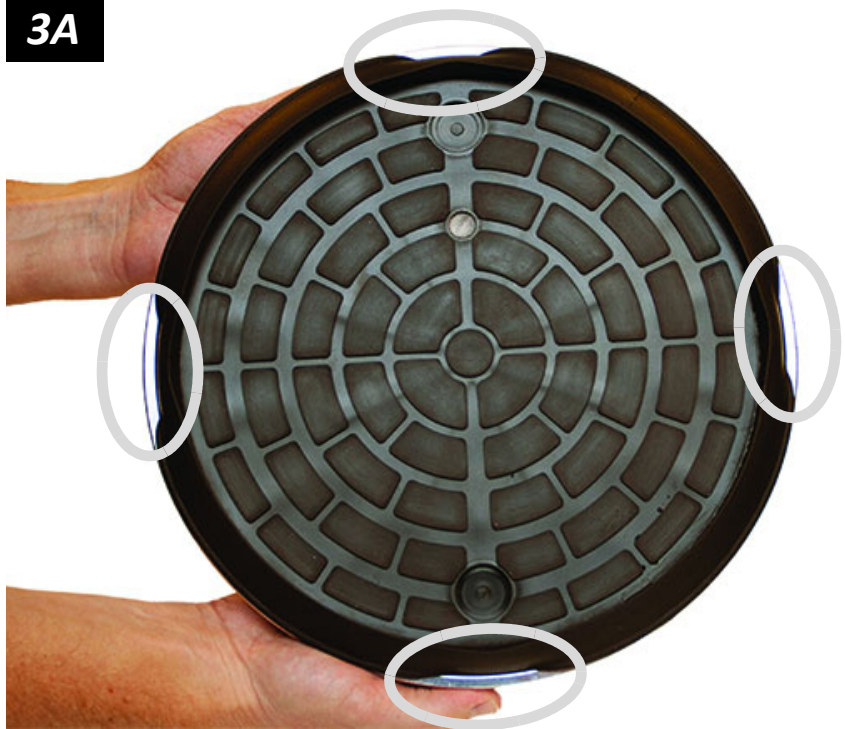
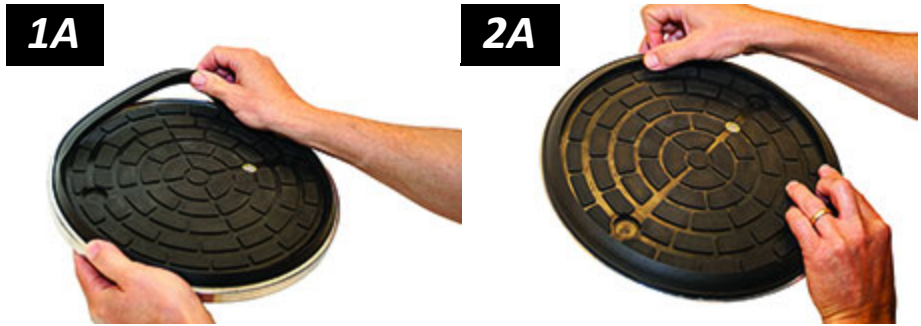

*Note: If any part of the sealing ring comes out of the mounting groove, inspect the sealing ring for damage and reinstall an undamaged sealing ring.*

# REPLACEMENT PARTS

Stock No.	Description	Qty.
93012	Pad Shutoff Valve	**
65430	Vacuum Hose – 7/32" ID x 0.43" ID — Black	*
65320	Lift Sling – 2' Length	2
65301	Handle Grip Foam	**
65014	Pad Spring – Wave Type (for HV11 pads)	**
65010	Pad Spring – Coil Type (for VPFS10T pads)	**
54214	Foam Washer	2
53132	Hose Fitting – Tee – 5/32" ID	**
53128	Pad Fitting – Tee – 5/32" ID	**
53122	Pad Fitting – Elbow – 5/32" ID	**
49724TT	Sealing Ring for VPFS10T Pad – Closed Cell Foam	**
49724RT	Sealing Ring for VPFS10T Pad – Heat-Resistant Rubber	**
49672FT	Vacuum Pad – VPFS10T / 10" [25 cm] Diameter – w/Replaceable Sealing Ring	**
49605T	Vacuum Pad – Model HV11 / 10" [25 cm] Diameter – Lipped (option)	**
49122	End Plug – 2" x 2" x 1/4" Tubing Size	6
36112	Service Manual – Compressed-Air Power System	1
29353	Pad Cover	**
20050	Pad Ring Installation Tool	1
16057	Quick Connector – 1/8 FNPS – Male End	1
16056	Quick Connector – 1/8 FNPS – Female End	1
15632	Pad Filter Screen – Small (for VPFS10T pads)	**
15630	Pad Filter Screen – Large (for HV11 pads)	**
10900	Shoulder Bolt – Socket Head – 5/16" x 1/2" x 1/4-20 Thread (for mounting pads)	**

\* — Length as required; sold by the foot (approx 30.5 cm).

\*\*— Quantity as required

See **SERVICE MANUAL #36112** for additional parts.

**SERVICE ONLY WITH IDENTICAL REPLACEMENT PARTS,  
AVAILABLE AT [WPG.COM](http://WPG.COM) OR THROUGH AN AUTHORIZED WPG DEALER**

# LIMITED WARRANTY

Wood's Powr-Grip® (WPG) products are carefully constructed, thoroughly inspected at various stages of production, and individually tested. They are warranted to be free from defects in workmanship and materials for a period of one year from the date of purchase.

If a problem develops during the warranty period, follow the instructions below to obtain warranty service. If inspection shows that the problem is due to defective workmanship or materials, WPG will repair the product without charge.

## **Warranty does not apply when ...**

- modifications have been made to the product after leaving the factory
- rubber portions have been cut or scratched during use;
- repairs are required due to abnormal wear and tear, and/or;
- the product has been damaged, misused or neglected.

If a problem is not covered under warranty, WPG will notify the customer of costs prior to repair. If the customer agrees to pay all repair costs and to receive the repaired product on a C.O.D. basis, then WPG will proceed with repairs.

## **TO OBTAIN REPAIRS OR WARRANTY SERVICE**

### **For purchases in *North America*:**

Contact the WPG Technical Service Department. When factory service is required, ship the complete product – prepaid – along with your name, address and phone number to the street address listed at the bottom of this page. WPG may be reached by phone or fax numbers listed below.

### **For purchases in all *other localities*:**

Contact your dealer or the WPG Technical Service Department for assistance. WPG may be reached by phone or fax numbers listed below.

Wood's Powr-Grip Co., Inc.  
908 West Main St.  
Laurel, MT 59044 USA

406-628-8231 (phone)  
800-548-7341 (phone)  
406-628-8354 (fax)