

8274-4 PLANETARY GRINDER

SERVICE MANUAL



Read Manual Before Servicing Machine

402973 Rev B

Table of Contents

Table of Contents	3
Specifications	4
Safety	6
Troubleshooting Guide	7
Maintenance	8
General Maintenance	8
Belt Procedures	9
Complete Parts List	14
Parts List and Diagrams	15
Warranty	18

Specifications



Product Specifications

Width	Height (Min.-Max.)	Length (Min.-Max.)	Weight	Disc Size	Power / Frequency	HP	Motor
20" (51 cm)	27.5-52" (70-132 cm)	38.5-75" (98-190.5 cm)	388 lbs (176 kg)	18.5" (47 cm)	120 V / 60 Hz, single phase input	3	3-Phase operation

GENERAL RULES FOR SAFE OPERATION

Before use, anyone operating or performing maintenance on this equipment must read and understand this manual, as well as any labels packaged with or attached to the machine and its components. Read the manual carefully to learn equipment applications and limitations, as well as potential hazards associated with this type of equipment. Keep manual near machine at all times. If your manual is lost or damaged, contact National Flooring Equipment (NFE) for a replacement.

Personal

Dress properly and use safety gear.

Do not wear loose clothing; it may be caught in moving parts. Anyone in the work area must wear safety goggles or glasses, hearing protection during extended use, and a dust mask for dusty operations. Hard hats, face shields, safety shoes, etc. should be worn when specified or necessary.

Maintain control; stay alert.

Keep proper footing and balance, and maintain a firm grip. Observe surroundings at all times and use common sense. Do not use when tired, distracted, or under the influence of drugs, alcohol, or any medication that may cause decreased control.

Keep hands away from all moving parts and tooling.

Wear gloves when changing tooling. Remove tooling when machine is not in use and/or lower cutting head to the floor.

Do not force equipment.

Equipment will perform best at the rate for which it was designed. Excessive force only causes operator fatigue, increased wear, and reduced control.

Environment

Avoid use in dangerous environments.

Do not use in rain, damp or wet locations, or in the presence of explosive atmospheres (gaseous fumes, dust, or flammable materials). Remove materials or debris that may be ignited by sparks. Keep work area tidy and well-lit - a cluttered or dark work area may lead to accidents. Extreme heat or cold may affect performance.

Protect others in the work area and be aware of surroundings.

Provide barriers or shields as needed to protect others from debris and machine operation. Children and other bystanders should be kept at a safe distance from the work area to avoid distracting the operator and/or coming into contact with the machine. Operator should be aware of who is around them and their proximity. Support personnel should never stand next to, in front of, or behind the machine while the machine is running. Operator should look behind them before backing up.

Guard against electric shock.

Ensure that machine is connected to a properly grounded outlet. Prevent bodily contact with grounded surfaces, e.g. pipes, radiators, ranges, and refrigerators. When scoring or making cuts, always check the work area for hidden wires or pipes.

Maintenance & Repairs

Begin maintenance work only when the machine is shut down, unplugged, and cooled down.

Use proper cleaning agents.

Ensure that all cleaning rags are fiber-free; do not use any aggressive cleaning products.

Schedule regular maintenance check-ups.

Ensure machine is properly cleaned and serviced. Remove all traces of oil, combustible fuel, or cleaning fluids from the machine and its connections and fittings. Retighten all loose fittings found during maintenance and repair work. Loose or damaged parts should be replaced immediately; use only NFE parts.

Do not weld or flame-cut on the machine during repairs, or make changes to machine without authorization from NFE.

Equipment

Use proper parts and accessories.

Only use NFE-approved or recommended parts and accessories. Using any that are not recommended may be hazardous.

Ensure accessories are properly installed and maintained.

Do not permanently remove a guard or other safety device when installing an accessory or attachment.

Inspect for damaged parts.

Check for misalignment, binding of moving parts, loose fasteners, improper mounting, broken parts, and any other conditions that may affect operation. If abnormal noise or vibration occurs, turn the machine off immediately. Do not use damaged equipment until repaired. Do not use if power switch does not turn machine on and off. For all repairs, insist on only identical NFE replacement parts.

Maintain equipment and labels.

Keep handles dry, clean, and free from oil and grease. Keep cutting edges sharp and clean. Follow instructions for lubricating and changing accessories. Motor and switches should be completely enclosed at all times with no exposed wiring. Inspect cord regularly. Labels carry important information; if unreadable or missing, contact NFE for a free replacement.

Avoid accidental starting; store idle equipment.

When not in use, ensure that the machine is unplugged; do not turn on before plugging in. Store in a dry, secured place. Remove tooling when storing, and keep away from children.



CAUTION! ENSURE PROPER USE OF EXTENSION CORDS. IF AMP DRAW IS HIGHER THAN SHOWN ON TABLE OR CORD IS LONGER THAN 50 FT, SEE AN ELECTRICIAN.

ASSUMPTIONS: 3% ALLOWABLE VOLTAGE DROP, COPPER CONDUCTORS RATED FOR 75°C, 1.25 SAFETY FACTOR, CORD VOLTAGE RATING OF 600VAC, PROPER CORD TYPES (STO, STOW, SOOW).

Amp Draw	Gauge
0-12	14
13-16	12
14-24	10
25-40	8

Safety

GRINDER SAFETY GUIDELINES

Before use, anyone operating this equipment must read and understand these safety instructions.

Grinding

Beware of hidden obtrusions.

Watch out for hidden dangers and protrusions in flooring. Do not use on largely uneven surfaces.

Avoid contact with hot tooling and shroud.

Do not touch the tooling or shroud without proper hand protection. Both become hot during operation and remain hot after stopping the machine.

Use correct tooling and accessories.

Provide barriers or shields as needed to protect others from debris.

Use for correct applications.

Do not force equipment to do heavier duty work than it was made for.

Do not block the machine's air flow.

Blocking ventilation slots or air flow will result in damage to the machine. Leave space for air to flow freely during operation.

Use dead man cable during operation.

Loss of control of the grinder could cause damage, injury, or death.

Dust Collection

Use with appropriate dust collecting system.

Do not operate machine designed for use with a dust collector without the dust collector. Ensure dust collector is on and operating properly while grinding.

Use with appropriate dust collection hose.

Do not operate the machine without the hose securely attached to the inlet of the dust collector and the outlet of the grinder. In order to maintain system efficiency, do not use a damaged hose.

Dispose of collected waste.

Do not leave the dust collector bag full of waste. Handle and dispose of bag and waste in accordance with all applicable local, state, and federal regulations. Dispose of waste prior to transport.

Battery (Propane Machines Only)

Remove personal metal items when working with battery.

A battery can produce a short circuit current sufficient enough to weld metal objects, causing severe burns. Be careful to not drop metal tools on the battery, as a spark or short circuit could cause an explosion.

Never smoke or allow a spark or flame near the battery.



WARNING: BE CAUTIOUS WHEN WORKING WITH BATTERY. IF ELECTROLYTIC ACID GETS IN THE EYES, IMMEDIATELY FLUSH OUT WITH COLD, FRESH WATER FOR AT LEAST 10 MINUTES AND GET MEDICAL HELP.



WARNING: GRINDING/CUTTING/DRILLING OF MASONRY, CONCRETE, METAL AND OTHER MATERIALS CAN GENERATE DUST, MISTS AND FUMES CONTAINING CHEMICALS KNOWN TO CAUSE SERIOUS FATAL INJURY OR ILLNESS, SUCH AS RESPIRATORY DISEASE, CANCER, BIRTH DEFECTS OR OTHER REPRODUCTIVE HARM. IF YOU ARE UNFAMILIAR WITH THE RISKS ASSOCIATED WITH THE PARTICULAR MATERIAL BEING CUT, REVIEW THE MATERIAL SAFETY DATA SHEET AND/OR CONSULT YOU EMPLOYER, THE MATERIAL MANUFACTURER/SUPPLIER, GOVERNMENTAL AGENCIES SUCH AS OSHA AND NIOSH AND OTHER AUTHORITIES ON HAZARDOUS MATERIALS. CALIFORNIA AND SOME OTHER AUTHORITIES, FOR INSTANCE, HAVE PUBLISHED LISTS OF SUBSTANCES KNOWN TO CAUSE CANCER, REPRODUCTIVE TOXICITY, OR OTHER HARMFUL EFFECTS. CONTROL DUST, MIST AND FUMES AT THE SOURCE WHERE POSSIBLE. IN THIS REGARD USE GOOD WORK PRACTICES AND FOLLOW THE RECOMMENDATIONS OF THE MANUFACTURER/SUPPLIER, OSHA/NIOSH, AND OCCUPATIONAL AND TRADE ASSOCIATIONS. WHEN THE HAZARDS FROM INHALATION OF DUST, MISTS AND FUMES CANNOT BE ELIMINATED, THE OPERATOR AND ANY BYSTANDERS SHOULD ALWAYS WEAR A RESPIRATOR APPROVED BY OSHA/MSHA FOR THE MATERIAL BEING CUT.

Troubleshooting Guide

Fault Code Status Light	Fault Description	Problem	Solution
SOLID ON	Check safety tether	Safety tether is disconnected from controller or faulty connection internally with tether switch.	Attach safety tether to control box. If necessary, check connections inside controller. Ensure control box is disconnected from power source prior to opening control box.
2 FLASHES	Power line voltage too low	Not enough power coming into controller to start or run grinder.	Be sure to use the appropriate extension cord (see Safety) and/or generator (10 kW, 115V if applicable).
3 FLASHES	Power line voltage too high	Excessive power coming into controller.	Ensure grinder is plugged into an outlet and/or generator (if applicable) with the appropriate voltage.
4 FLASHES	Motor short circuit or overload	Motor may be overheating due to using too long of an extension cord or because the outlet/generator is the wrong voltage.	Allow motor to cool before resetting fault code. Reduce amp draw by removing weights from grinder deck and/or reducing motor's RPM. Ensure use of proper extension cord, outlet, and/or generator.
5 FLASHES	Controller overheating	Internal components of controller are too hot.	Ensure external fan is plugged into controller and is working properly. Reduce amp draw by removing weights from grinder deck and/or reducing motor's RPM.
6 FLASHES	Open motor phases	No power from controller motor.	Ensure motor is properly connected to control box.
NO FLASHING LIGHTS or ANY LIGHTS AT ALL	No illuminated status lights or fault codes	Reset power supply circuit breaker if necessary; if the power source is working, it is likely the fuse inside the control box is blown.	Prior to opening control box, ensure it is disconnected from power source. Wait 30 seconds for power to discharge from capacitors after disconnecting. Replace fuse.

Maintenance

GENERAL MAINTENANCE

A well-maintained machine is a productive machine. If not properly maintained, it could be unsafe or break down. Schedule regular maintenance check-ups to ensure efficient performance and a long life. The following maintenance should be performed by a service center:

- Mechanical inspection and cleaning (pulleys, belts, bearings, nuts, bolts, housing, labels, etc.).
- Replacing worn or damaged parts (switches, guards, belts, etc.).
- Electrical inspection (switch, cord, plugs, etc.).
- Testing to assure proper mechanical and electrical operation.
- Replacing labeling.



WARNING: BEFORE PERFORMING ANY MAINTENANCE WORK, DISCONNECT THE TOOL FROM THE POWER SOURCE.



WARNING: NEVER DISASSEMBLE THE MACHINE OR TRY TO DO ANY REWIRING ON THE MACHINE'S ELECTRICAL SYSTEM. CONTACT NATIONAL FLOORING EQUIPMENT FOR ALL ELECTRICAL REPAIRS.



WARNING: TO REDUCE THE RISK OF INJURY, ELECTRIC SHOCK AND DAMAGE TO THE MACHINE, NEVER IMMERSE YOUR MACHINE IN LIQUID OR ALLOW A LIQUID TO FLOW INSIDE THE MACHINE.

Keep machine in good repair by adopting a regular maintenance program. Before use, examine the general condition. If abnormal noise or vibration occurs, turn the grinder off immediately and have the problem corrected before further use.

Cleaning

- Clean dust and debris from wheels and housing.
- Keep the grinder handle clean, dry, and free of oil or grease.
- Use only mild soap and a damp cloth to clean machine, as some cleaning agents and solvents are harmful to plastics and other insulated parts. Some of these include: gasoline, turpentine, lacquer thinner, paint thinner, chlorinated cleaning solvents, ammonia and household detergents containing ammonia. Never use flammable or combustible solvents around machinery.
- Do not pressure-wash grinder. Getting motor or control box wet could cause electric shock or damage the grinders electrical components.



FIG. 1



FIG. 1.1

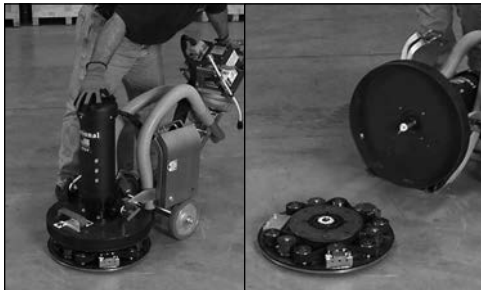

FIG. 1.2

FIG. 1.3



FIG. 2

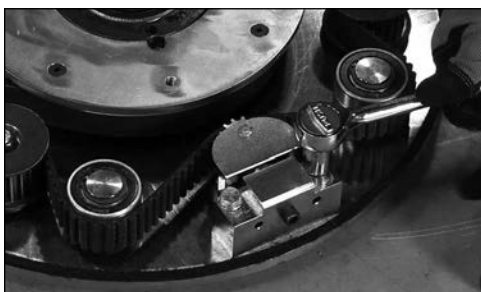

FIG. 3

BELT PROCEDURES



CAUTION: BEFORE ANY MAINTENANCE, MAKE SURE MACHINE IS DISCONNECTED FROM POWER SOURCE

Note: Blue Loctite should be used on tensioner bolts. Torque on 3/8" bolts should not exceed 25 lbs.

To Access Belt

1. Remove dust guard (Figure 1).
2. Remove the four bolts on top of the shroud cover (Figure 1.1).
3. Push down on the handle. The shroud should lift up and away from the grinding deck. If not, with the four bolts on top of the shroud cover removed, tip the grinder deck back to the tool changing position. Insert a 1/2"-13x4" threaded bolt into the center of the underside of the deck plate. Turn bolt in clockwise until deck is free of grinder shroud. Remove bolt and the shroud should now lift up and away from the grinding deck (Figure 1.2).
4. Move machine back and off the plate (Figure 1.3).

Removing Belt

1. Remove any dust or debris from inside the deck.
2. Using an Allen wrench, install the 5/16-18x1 1/4" socket head cap screws into each tensioner and compress the block spring by turning the screw clockwise. The belt should be loose enough to slide off.
3. Leave approximately 1/8" gap when compressing the block spring to allow clearance for removing the tensioner mounting bolts (Figure 2).
4. Remove one mounting bolt completely; loosen the other (Figure 3).

Maintenance

Replacing Belt

1. Deck should now be in the orientation shown (Figure 4) before installing new belt, clean any debris from the deck before moving on.
2. Install belt around the center gear; pull the excess through the gap by the counter weight (Figure 4.1).
3. Keep the smooth side of the belt against the idlers and flip the belt over the deck. The teeth on the belt will face outward.
4. A properly installed belt should appear as shown (Figure 4.2).
5. Turn one tensioner into place and install the bolt (Figure 4.3).
6. Push the second tensioner into the belt until the mounting hole lines up with the block; install the second bolt.
7. Once both tension blocks are installed, remove the collapsing bolts.
8. Use pliers to rotate the shaft on the bottom of the machine so the key is in the 12 o'clock position (Figure 4.4).
9. Turn the deck so the keyway in the hub is also in the 12 o'clock position (Figure 4.5). **Note:** Use anti-seize on the shaft and in the center of the deck to protect against corrosion.
10. Hold the motor straight while lining up the shaft with the hub in the deck.
11. Press evenly on the top of the motor or deck until the shroud is seated on the deck.
12. Re-install the four bolts around the base of the reducer. The shroud may need to be rotated to line up with the holes. Do not crossthread bolts when installing.
13. Test machine thoroughly to ensure correct operation.

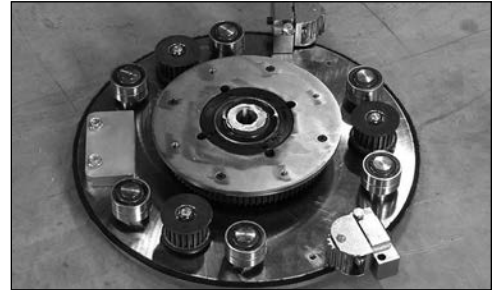

FIG. 4

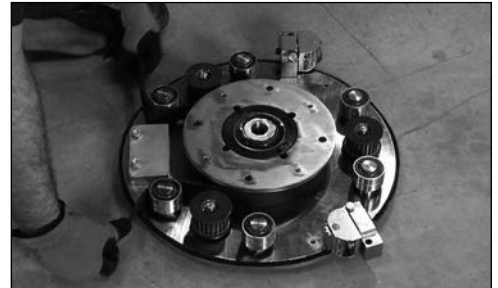

FIG. 4.1



FIG. 4.2

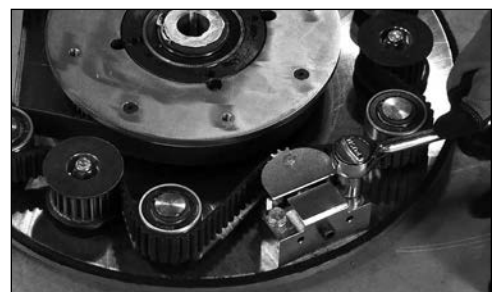

FIG. 4.3

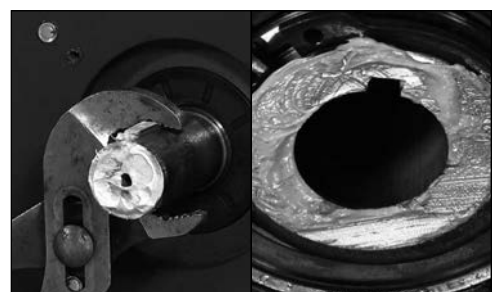

FIG. 4.4

FIG. 4.5



FIG. 5

IDLE BEARING REPLACEMENT

1. Remove belt.
2. Remove snap ring (Figure 5).
3. Remove idler bearings (Figure 5.1) .
4. Replace bearing.
5. Replace snap ring; ensure ring is seated in the groove (Figure 5).
6. Re-install belt.



FIG. 5.1

PULLEY REPLACEMENT

1. Remove belt.
2. Remove nut from top of pulley.
3. Slide pulley up and off. Key will fall out (Figure 6).
4. Place and line up key in new pulley.
5. Install pulley.
6. Re-insert nut.
7. Re-install belt.

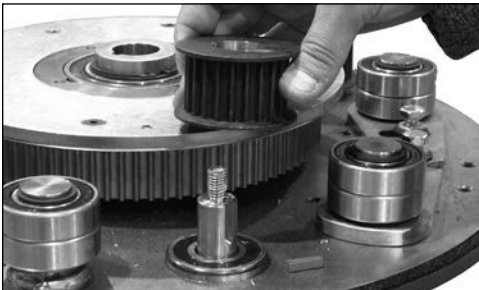

FIG. 6

SATELLITE SHAFT REPLACEMENT

1. Remove belt.
2. Remove nut from top of pulley.
3. Slide pulley up and off. Key will fall out (Figure 6).
4. Push down on shaft (Figure 6.1).
5. Lift up on plate and pull out shaft (Figure 6.2).
6. Replace shaft (Figure 6.3).
7. Place and line up key in new pulley.
8. Install pulley.
9. Replace nut.
10. Re-install belt.



FIG. 6.1



FIG. 6.2

Maintenance

SATELLITE BEARING REPLACEMENT

1. Remove belt.
2. Remove nut from top of pulley.
3. Slide pulley up and off. Key will fall out (Figure 6).
4. Remove satellite shaft (Figure 6.3).
5. Block up plate (Figure 7).
6. Knock out bearing (Figure 7.1) .
7. Turn plate over on blocks (Figure 7.2).
8. With the retainer ring turned upwards, replace the bearing (Figure 7.2), keeping the bearing as straight as possible (Figure 7.3). **Note:** Bearing can be difficult to insert.
9. Replace shaft.
10. Place and line up key in new pulley.
11. Install pulley.
12. Replace nut.
13. Re-install belt.

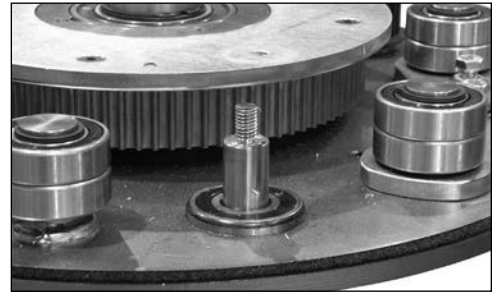

FIG. 6.3

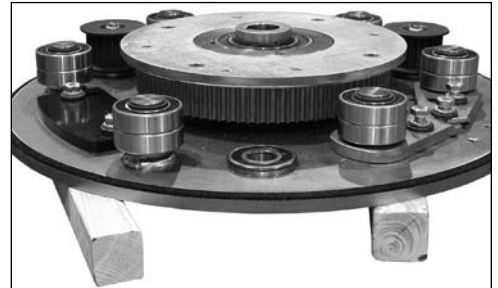

FIG. 7

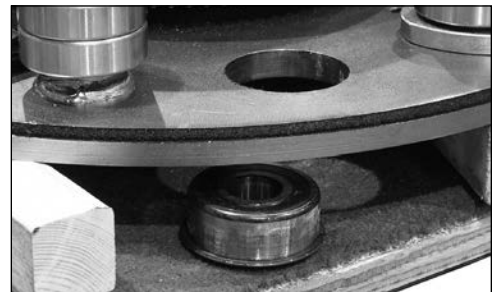

FIG. 7.1

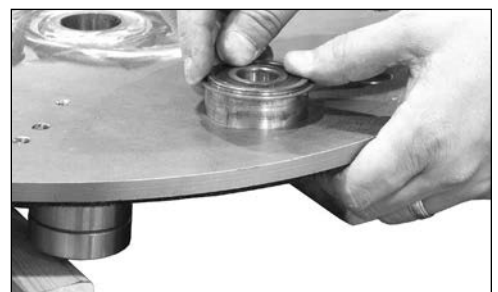

FIG. 7.2

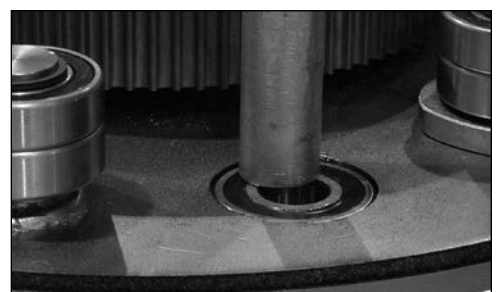

FIG. 7.3



FIG. 8



FIG. 8.1

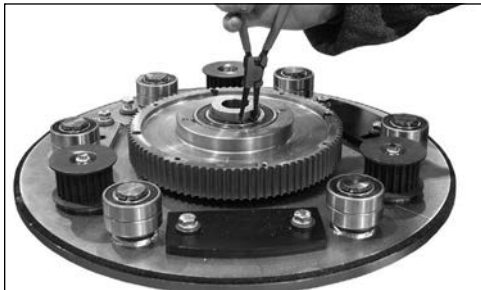

FIG. 8.2

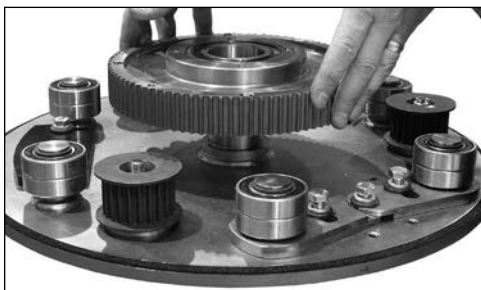

FIG. 8.3

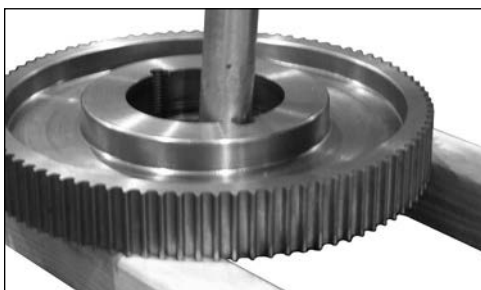

FIG. 8.4

REMOVING TOP GEAR PLATE

1. Remove belt.
2. With an Allen wrench, remove the four gear plate cover screws (Figure 8).
3. Remove gear plate (Figure 8.1).
4. Remove both snap rings (Figure 8.2).
5. Remove gear (Figure 8.3).
6. Block up gear (Figure 8.4).
7. Knock out bearings.
8. Re-install bearings one at a time. **Note:** When hitting around outside perimeter of the bearing, keep bearing as straight as possible.
9. Place gear back onto plate, keeping fingers clear (Figure 8.3).
10. Wiggle bearing until it drops into place. Do not force; be aware of the pinch points.
11. Re-insert snap rings; ensure they are seated in the groove.
12. Re-insert gear plate.
13. Re-insert the four screws.
14. Re-install belt.

Complete Parts List

PART#	DESCRIPTION	QTY	PART#	DESCRIPTION	QTY		
1	80024	BLOCK, PLANETARY HANDLE	1	29	401640	REDUCER, GRINDER, GROVE	1
2	80026	TUBE, OVAL, PLANETARY HANDLE	1	30	73201	SCREW, HEX HEAD CAP, 3/8-16X1	4
3	80035	TUBE, INNER WELDMENT	1	31	L106	PINCH POINT LABEL	2
4	80036	TUBE, OUTER WELDMENT	1	32	73604	NUT, NYLON LOCK 3/4-10	2
5	80037	FRAME, PLANETARY HANDLE	1	33	80047	PIN, 3/8"X3-5/8, QUICK RELEASE	1
6	80039	SPLITTER, VAC	1	34	73410	BOLT, HEX HEAD CAP, 1/2-13X3-1/2	2
7	8274-46	BRACKET, CONTROLLER 8274	1	35	73417	BOLT, HEX HEAD CAP 1/2-13X4	1
8	400390	PLATE, MOUNTING, CONTROLLER	2	36	73424	WASHER, FLAT, ZINC SAE 1/2	11
9	400124	HOSE, VACUUM 2" DIA, 3' CUT, W/CUFFS	2	37	8274-29	BELT	1
10	7274-200	WHEEL	2	38	400204	SCREW, SET, NYLON 1/2-13X3/4	1
11	401431	WEIGHT, CAST, GRINDER	4	39	73202	WASHER, INTERNAL LOCK 3/8	8
12	401549	CONTROLLER 115V, 1 PH, VFD	1	40	73204	WASHER, LOCK 3/8	11
13	402339	GUARD, RUBBER DUST, VELCRO, 6.5 X 65.00	1	41	73207	NUT, NYLOCK 3/8-16	3
14	8274-53	PLATE, BASE, GEAR BOX	1	42	73216	BOLT, HEX HEAD CAP SCREW 3/8-16X1-3/4	4
15	8274-27	PULLEY, 90 TOOTH	1	43	73223	BOLT, FLANGE 3/8016X1-1/4	2
16	8274-33	PLATE, PULLEY	1	44	73252	BOLT, HEX HEAD CAP 3/8-16X4 1/2	1
17	8274-64	PLANETARY, 18"	1	45	73263	WASHER, FLAT SAE ZINC 3/8	4
18	8274-68	TENSIONER, PLANETARY BELT	2	46	73309	SCREW, SOCKET HEAD CAP 5/16-18X3/4	2
19	8274-69	WEIGHT, COUNTER	1	47	73401	NUT, STRAIN RELIEF, STEEL 1/2"	2
20	71222	BEARING, 20MM ID	3	48	73402	NUT, NYLOCK 1/2-13	3
21	71232	BEARING, 20MM ID 1DC	12	49	L189	LABEL ASBESTOS HD	1
22	73037	BOLT, FLAT HEAD SOCKET CAP 1/4-20X1	4	50	L193	LABEL, 8274-4	1
23	73208	BOLT, HEX HEAD CAP 3/8-16X1-1/2	4	51	L223	LABEL, PATENT NUMBER	1
24	73237	WASHER, HARDENED DIE 3/8	3	52	L265	LABEL, SILICA DUST	1
25	73904	KEY, 3/16X3/16X3/4	3	53	L33B	LABEL, CAUTION MOVING PART	1
26	80043	PULLEY, 22 TOOTH	3	54	L49	LABEL, CORD CAUTION	1
27	80049	SHAFT, SCRUBBER, WELDMENT	3				
28	400388	MOTOR, 3 HP, 230/480	1				

Parts List and Diagrams

PART#	DESCRIPTION	QTY	
1	80024	BLOCK, PLANETARY HANDLE	1
2	80026	TUBE, OVAL, PLANETARY HANDLE	1
3	80035	TUBE, INNER WELDMENT	1
4	80036	TUBE, OUTER WELDMENT	1
5	80037	FRAME, PLANETARY HANDLE	1
6			
7	80039	SPLITTER, VAC	1
8	8274-46	BRACKET, CONTROLLER 8274	1
9	400390	PLATE, MOUNTING, CONTROLLER	2

HANDLE PARTS

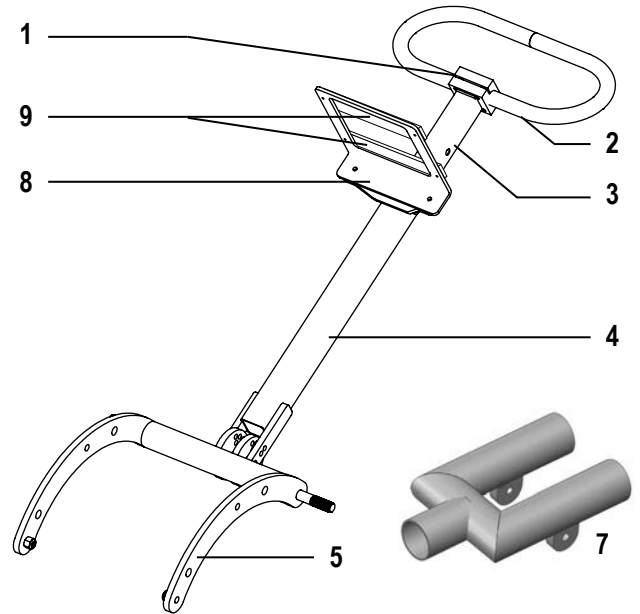

PART#	DESCRIPTION	QTY	
1	400124	HOSE, VACUUM 2" DIA, 3' CUT, W/CUFFS	2
2	7274-200	WHEEL	2
3	401431	WEIGHT, CAST, GRINDER	4
4	401549	CONTROLLER 115V, 1 PH, VFD	1
5	402339	GUARD, RUBBER DUST, VELCRO, 6.5 X 65.00	1
6	8274-53	PLATE, BASE, GEAR BOX	1

EXTERNAL PARTS

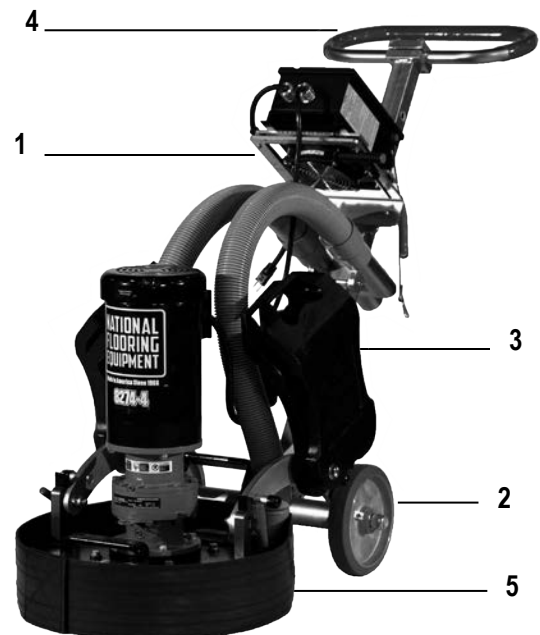

Parts List and Diagrams

18" DECK ASSEMBLY

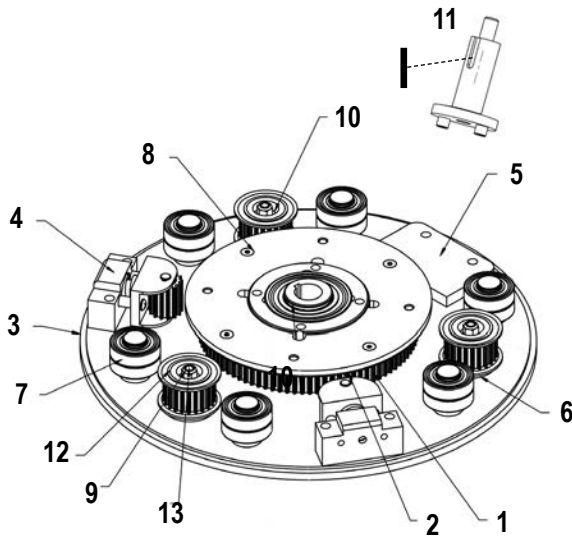

	PART#	DESCRIPTION	QTY
1	8274-27	PULLEY, 90 TOOTH	1
2	8274-33	PLATE, PULLEY	1
3	8274-64	PLANETARY, 18"	1
4	8274-68	TENSIONER, PLANETARY BELT	2
5	8274-69	WEIGHT, COUNTER	1
6	71222	BEARING, 20MM ID	3
7	71232	BEARING, 20MM ID 1DC	12
8	73037	BOLT, FLAT HEAD SOCKET CAP 1/4-20X1	4
9	73208	BOLT, HEX HEAD CAP 3/8-16X1-1/2	4
10	73237	WASHER, HARDENED DIE 3/8	3
11	73904	KEY, 3/16X3/16X3/4	3
12	80043	PULLEY, 22 TOOTH	3
13	80049	SHAFT, SCRUBBER, WELDMENT	3

MOTOR

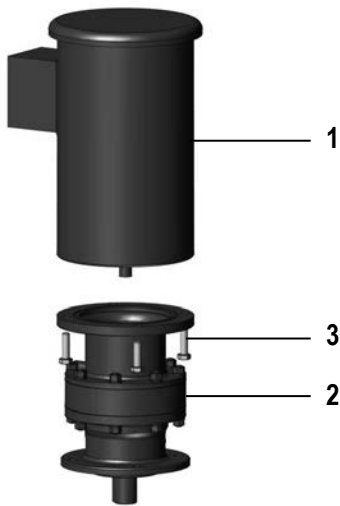

	PART#	DESCRIPTION	QTY
1	400388	MOTOR, 3 HP, 230/480	1
2	401640	REDUCER, GRINDER, GROVE	1
3	73201	SCREW, HEX HEAD CAP, 3/8-16X1	4

Parts List and Diagrams

PARTS NOT SHOWN

PART#	DESCRIPTION	QTY	PART#	DESCRIPTION	QTY
1	L106	2	14	73252	1
2	73604	2	15	73263	4
3	80047	1	16	73309	2
4	73410	2	17	73401	2
5	73417	1	18	73402	3
6	73424	11	19	L189	1
7	8274-29	1	20	L193	1
8	400204	1	21	L223	1
9	73202	8	22	L265	1
10	73204	11	23	L33B	1
11	73207	3	24	L49	1
12	73216	4			
13	73223	2			

Warranty

National Flooring Equipment Inc. (referred to as "the Company") warrants that each new unit manufactured by The Company, to be free from defects in material and workmanship in normal use and service for a period of twelve (12) months from date of shipment from the Company. For administrative ease, will honor warranty for a period of fifteen (15) months from date of shipment from the company. Accessories or equipment furnished and installed on the product by the Company but manufactured by others, including but not limited to: engines, motors, electrical components, transmissions etc., shall carry the accessory manufacturers own warranty. Battery warranties are prorated over the warranty period. Customer is responsible for the inspection of equipment / parts upon delivery. Freight damages reported beyond authorized time frame will not be honored.

The Company, at its determination of defect, will repair or replace any product or part deemed to be defective in material or workmanship within specified warranty time period. All product determinations and / or repairs will take place at the designated Company repair facility, or at a certified warranty location designated by the Company. The Company will coordinate and be responsible for all freight expenses associated with valid warranty claims. Freight and shipping expenses associated with abuse or misuse will be back charged to the Distributor/Customer. The Company reserves the right to modify, alter or improve any part / parts without incurring any obligation to replace any part / parts previously sold without such modified, altered or improved part / parts. In no event shall the seller or manufacturer of the product be liable for special, incidental, or consequential damages, including loss of profits, whether or not caused by or resulting from the negligence of seller and / or the manufacturer of the product unless specifically provided herein. This warranty shall not apply to any products or portions there of which have been subjected to abuse, misuse, improper installation or operation, lack of recommended maintenance, electrical failure or abnormal conditions and to products which have been tampered with, altered, modified, repaired, reworked by anyone not approved or authorized by the Company or used in any manner inconsistent with the provisions of the above or any instructions or specifications provided with or for the product. Any and all unauthorized onsite warranty work conducted by unauthorized personnel or any outside person(s), is not covered by the Company unless the work has been pre-authorized by a predetermined manufacturer representative. This excludes wearable parts and/or consumables.

Defective or failed material or equipment shall be held at the purchaser's premises until authorization has been granted by the Company to return or dispose of defective products. Products returned for final inspection must be returned with a manufacturer authorized Return Material Authorization (RMA). Any unauthorized return of equipment will be declined at the dock by the Company. Any non-approved items returned with approved returned items are subject to rejection and will not be credited. Credit will be issued for material found to be defective upon the Company's inspection based on prices at time of purchase.

TO OBTAIN SERVICE CONTACT NATIONAL FLOORING EQUIPMENT, INC. TOLL FREE AT 800-245-0267 FOR A REPAIR AUTHORIZATION NUMBER. COD FREIGHT RETURNS WILL NOT BE ACCEPTED. FREIGHT COLLECT SHIPMENTS WILL NOT BE ACCEPTED. WARRANTY REPAIRS MUST BE ACCOMPANIED BY DATE OF PURCHASE RECEIPT AND A RETURN/REPAIR AUTHORIZATION NUMBER.

RETURN/REPAIR AUTHORIZATION NUMBER: _____

MACHINE SERIAL NUMBER: _____



Made in America Since 1968

9250 Xylon Avenue N • Minneapolis, MN 55445 • U.S.A.
Toll-free 800-245-0267 • Phone 763-315-5300 • Fax 800-648-7124 • Fax 763-535-8255
Web Site: www.nationalequipment.com • E-Mail: info@nationalequipment.com