

SMITH FS351™

3A7832B

EN

For removal of materials from flat horizontal concrete and asphalt surfaces. Not approved for use in explosive atmospheres or hazardous (classified) locations. Gas/propane units not for use indoors or in enclosed spaces. For professional use only.

Models 25P477/25R104 SMITH FS351 G DCS (High speed / Standard speed)

Models 25P478/25R105 SMITH FS351 P DCS (High speed / Standard speed)

Models 25P479/25R106 SMITH FS351 E DCS 480V (High speed / Standard speed)

Models 25P782/25R107 SMITH FS351 E DCS 380V (High speed / Standard speed)

Gas/Propane Maximum Working Pressure: 750 psi (52 bar, 5.2 MPa)

Electric Maximum Working Pressure: 1000 psi (69 bar, 6.9 MPa)



Important Safety Instructions

Read all warnings and instructions in this manual and in the Kohler engine manual before using the equipment. Be familiar with the controls and the proper usage of the equipment. Save these instructions.

Related Manuals:

62 590 13 - Kohler Owner's Manual (Gas)

24 590 52- Kohler Owner's Manual (Propane)

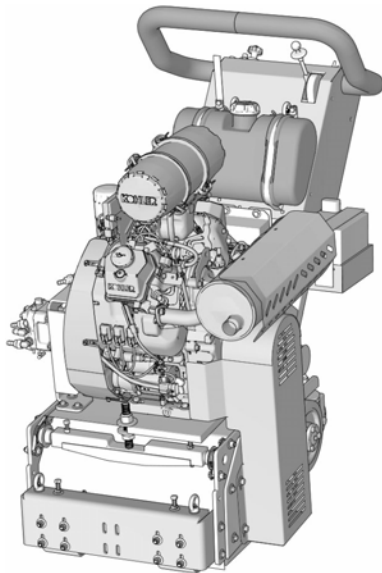

FS351 G DCS

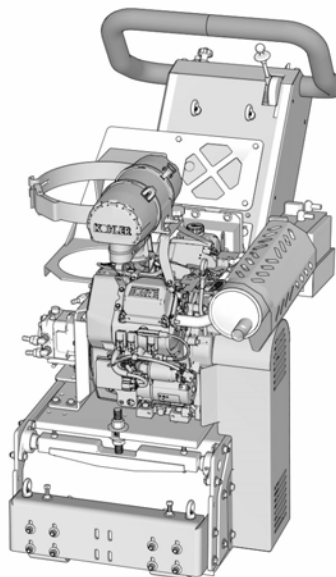

FS351 P DCS

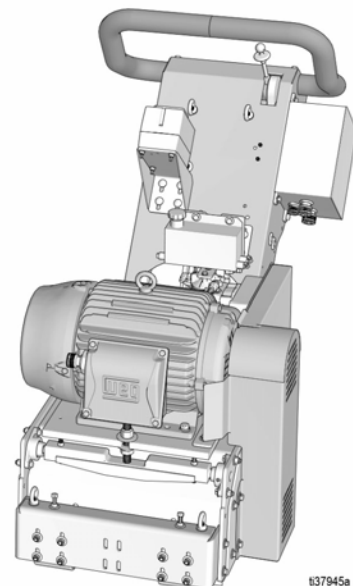

FS351 E DCS

t37945a









(Drums and cutters sold separately)

Contents

Warnings	3	Parts - Guidebar / Vacuum Assemblies (All Models) ..	38
Gasoline/Propane Engine Warnings	5	Parts List - Guidebar / Vacuum Hose Assemblies (All	
Electric Motor Warnings	6	Models)	39
Component Identification	7	Parts - Hydraulic Motor / Rear Assembly (All Models) .	40
FS351 G DCS (Gas)	7	Parts List - Hydraulic Motor / Rear Assembly (All Models)	
FS351 P DCS (Propane)	8	41	
FS351 E DCS (Electric)	9	Parts - Support System / Hydraulic Tank (All Models) .	42
Setup	10	Parts List - Support System / Hydraulic Tank (All Models)	
Propane Tank	10	43	
Lifting Instructions	10	Parts - Motor / Hydraulic Assemblies (Gas)	44
Handlebar Adjustment	11	Parts List - Motor / Hydraulic Assemblies (Gas)	45
Engine Kill Button (Gas/Propane)	11	Parts - Hydraulic Fittings / Fuel Tank Assemblies (Gas) .	46
Drum Installation/Replacement	12	Parts List - Hydraulic Fittings / Fuel Tank Assemblies (Gas)	
DCS Control	13	47	
Operation	17	Parts - Pulley Assemblies (Gas)	48
Machine Start Up (Gas & Propane)	17	Parts List - Pulley Assemblies (Gas)	49
Machine Start Up (Electric)	17	Parts - Dashboard / Battery Assemblies (Gas)	50
When operating... ..	18	Parts List - Dashboard / Battery Assemblies (Gas) ..	51
Hydrostatic Drive Operation	18	Parts - Motor / Hydraulic Assemblies (Propane)	52
DCS Instructions	19	Parts List - Motor / Hydraulic Assemblies (Propane) .	53
Repair	21	Parts - Propane Tank / Dashboard Assemblies (Propane)	54
Drive Belt Replacement	21	Parts List - Propane Tank / Dashboard Assemblies	
Hydraulic Belt Replacement (Electric Models only) ..	22	(Propane)	55
Bearing Housing Replacement	23	Parts - Pulley Assemblies (Propane)	56
Drive Pulley Replacement	24	Parts List - Pulley Assemblies (Propane)	57
Maintenance Checklist	25	Parts - Battery Assembly (Propane)	58
Gas/Propane Models only	25	Parts List - Battery Assembly (Propane)	59
All Models	25	Parts - Electrical Components (Electric)	60
Purge Procedures	26	Parts List - Electrical Components (Electric)	61
Front Wheel Adjustment	26	Parts - Hydraulic Motor Assemblies (Electric)	62
Recycling and Disposal	27	Parts List - Hydraulic Motor Assemblies (Electric) ...	63
Rechargeable Battery Disposal	27	Parts - Hydraulic Assembly (Electric)	64
End of Product Life	27	Parts List - Hydraulic Tank Assembly (Electric)	65
DCS Control Translations	28	Parts - Pulley Assemblies (Electric - 480V & 380V) ...	66
Troubleshooting	30	Parts List - Pulley Assemblies (Electric 480V & 380V)	67
DCS Error Codes	32	Wiring Diagram	68
DCS Actuator Rod Does Not Move	33	Gas Models	68
Parts - Main Housing Assembly (All Models)	34	Propane Models	69
Parts List - Main Housing Assembly (All Models)	35	Electric Models (480V)	70
Parts - Front Wheel / Wheel Carrier Assemblies (All Models)	36	Electric Models (380V)	71
Parts List - Front Wheel / Wheel Carrier Assemblies (All		Technical Data	72
Models)	37	SMITH Standard Warranty	74
		SMITH Information	74

Warnings

The following warnings are for the setup, use, grounding, maintenance, and repair of this equipment. The exclamation point symbol alerts you to a general warning and the hazard symbols refer to procedure-specific risks. When these symbols appear in the body of this manual or on warning labels, refer back to these Warnings. Product-specific hazard symbols and warnings not covered in this section may appear throughout the body of this manual where applicable.

 <h2 style="margin: 0;">WARNING</h2>	
 	<p>DUST AND DEBRIS HAZARD</p> <p>Grinding concrete and other surfaces with this equipment can create dust that contains hazardous substances. Grinding can also create flying debris.</p> <p>To reduce the risk of serious injury:</p> <ul style="list-style-type: none"> • Control the dust to meet all applicable workplace regulations. • Wear protective eye wear and a properly fit-tested and government approved respirator suitable for the dust conditions. • Use equipment only in a well-ventilated area. • Grinding equipment must be used only by trained personnel who understand the applicable workplace regulations.
  	<p>ENTANGLEMENT AND MOVING PARTS HAZARD</p> <p>Moving parts can pinch, cut or amputate fingers and other body parts.</p> <ul style="list-style-type: none"> • Keep clear of moving parts. • Do not operate equipment with protective guards or covers removed. • Do not wear loose clothing, jewelry or long hair while operating equipment. • Before checking, moving, or servicing equipment, disable power. For gas/propane units, disconnect negative (-) battery cable. For electric units, unplug power cord.
	<p>BURN HAZARD</p> <p>Cutters and engine can become very hot during operation. To avoid severe burns, do not touch hot equipment. Wait until equipment has cooled completely.</p>
 	<p>PERSONAL PROTECTIVE EQUIPMENT</p> <p>You must wear appropriate protective equipment when operating, servicing, or when in the operating area of the equipment to help protect you from serious injury, including eye injury, inhalation of dust or chemicals, burns, and hearing loss. This equipment includes but is not limited to:</p> <ul style="list-style-type: none"> • Protective eye wear. • Protective shoes. • Gloves. • Hearing protection. • Properly fit-tested and government approved respirator suitable for the dust conditions.



WARNING



SKIN INJECTION HAZARD

High-pressure fluid from hose leaks, or ruptured components will pierce skin. This may look like just a cut, but it is a serious injury that can result in amputation. **Get immediate surgical treatment.**



- Inspect hose before each use for cuts, bulges, kinks or any other damage.
- Replace damaged hose immediately.
- Replace hoses proactively at regular intervals based on your operating conditions.
- Tighten all fluid connections before operating the equipment.
- Keep clear of leaks.
- Do not stop or deflect leaks with your hand, body, glove, or rag.
- Never exceed hose Maximum Pressure or Temperature ratings.
- Only use chemicals that are compatible with hose materials. See **Technical Specifications** in this manual. Read Safety Data Sheets (SDSs) and fluid and solvent manufacturer's recommendations.









EQUIPMENT MISUSE HAZARD

Misuse can cause death or serious injury.

- Do not operate the unit when fatigued or under the influence of drugs or alcohol.
- Do not leave the work area while equipment is energized. Turn off all equipment when equipment is not in use.
- Check equipment daily. Repair or replace worn or damaged parts immediately with genuine manufacturer's replacement parts only.
- Do not alter or modify equipment.
- Use equipment only for its intended purpose. Call your distributor for information.
- Keep children and animals away from work area.
- Comply with all applicable safety regulations.
- Maintain a safe operating distance from other people in the work area.
- Avoid any pipes, columns, openings, or any other objects protruding from work surface.

Gasoline/Propane Engine Warnings

 <h1 style="margin: 0;">WARNING</h1>	
 	<p>FIRE AND EXPLOSION HAZARD -- GASOLINE</p> <p>Flammable fumes, such as solvent and paint fumes, in work area can ignite or explode. To help prevent fire and explosion:</p> <ul style="list-style-type: none"> • Use equipment only outdoors. Never use indoors or in enclosed spaces. • Do not fill fuel tank while engine is running or hot; shut off engine and let it cool. Fuel is flammable and can ignite or explode if spilled on hot surface. • Eliminate all ignition sources, such as pilot lights, cigarettes, and portable electric lamps. • Keep work area free of debris, including solvent, rags and gasoline. • Keep a fire extinguisher in work area.
 	<p>FIRE AND EXPLOSION HAZARD -- PROPANE (LP GAS)</p> <p>Propane is highly flammable and explosive. To help prevent fire and explosion:</p> <ul style="list-style-type: none"> • Use equipment only outdoors. Never use indoors or in enclosed spaces. • Eliminate all ignition sources, such as pilot lights, cigarettes, and portable electric lamps. • If you smell propane, shut off the machine immediately and close the propane tank fuel valve. Do not use machine until you identify and correct the problem. • Always turn off propane tank fuel valve when equipment is not in use. • Do not store propane tanks, or equipment with a propane tank, inside a building or enclosed area. • Keep a fire extinguisher in work area.
	<p>CARBON MONOXIDE HAZARD</p> <p>Exhaust contains poisonous carbon monoxide, which is colorless and odorless. Breathing carbon monoxide can cause death.</p> <ul style="list-style-type: none"> • Operate engine only outdoors. Never use indoors or in enclosed spaces.
 	<p>BATTERY HAZARD</p> <p>Lead-acid batteries produce explosive gases and contain sulfuric acid that can cause severe burns. To avoid sparks and injury when handling or working with a lead-acid battery:</p> <ul style="list-style-type: none"> • Read and follow the battery manufacturer's warnings. • Exercise caution when working with metallic tools or conductors to prevent short circuits and sparks. • Keep all sparks, flames, and cigarettes away from batteries. • Always wear protective eyewear and protective equipment for face, hands, and body. • If you have direct contact with battery fluid, flush with water and consult a physician immediately. • Installation and maintenance must be performed by knowledgeable personnel only.

Electric Motor Warnings



DANGER



SEVERE ELECTRIC SHOCK HAZARD

This equipment is powered by more than 240 V. Contact with this voltage will cause death or serious injury.



- Turn off and disconnect power cord before servicing equipment.
- Connect only to grounded electrical outlets.
- Use only 4-wire extension cords.
- Ensure ground prongs are intact on power and extension cords.
- Do not expose to rain. Store indoors.
- All electrical wiring must be done by a qualified electrician and comply with all local codes and regulations.



GROUNDING

This product must be grounded. In the event of an electrical short circuit, grounding reduces the risk of electric shock by providing an escape wire for the electric current. This product is equipped with a cord having a grounding wire with an appropriate grounding plug. The plug must be plugged into an outlet that is properly installed and grounded in accordance with all local codes and regulations.

- Improper installation of the grounding plug is able to result in a risk of electric shock.
- This product is for use on a nominal 480 V or 380 V circuit and has a grounding plug similar to the plugs illustrated in the figure below..

480 V

380 V

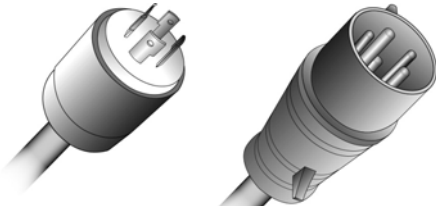

- Only connect the product to an outlet having the same configuration as the plug.
- Do not modify the plug provided; if it does not fit the outlet, have the proper outlet installed by a qualified electrician.
- Do not use an adapter with this product.
- When repair or replacement of the cord or plug is required, only connect the grounding wire to the extended ground blade or pin.
- The wire with insulation having an outer surface that is green with or without yellow stripes is the grounding wire.
- Check with a qualified electrician or serviceman when the grounding instructions are not completely understood, or when in doubt as to whether the product is properly grounded.
- Extension Cords:
 - Use only a 4-wire extension cord that has a grounding plug and a grounding receptacle that accepts the plug on the product.
 - Make sure your extension cord is not damaged. If an extension cord is necessary, use 10 AWG (6.0 mm²) minimum to carry the current that the product draws.
 - An undersized cord results in a drop in line voltage and loss of power and overheating.

Component Identification

FS351 G DCS (Gas)

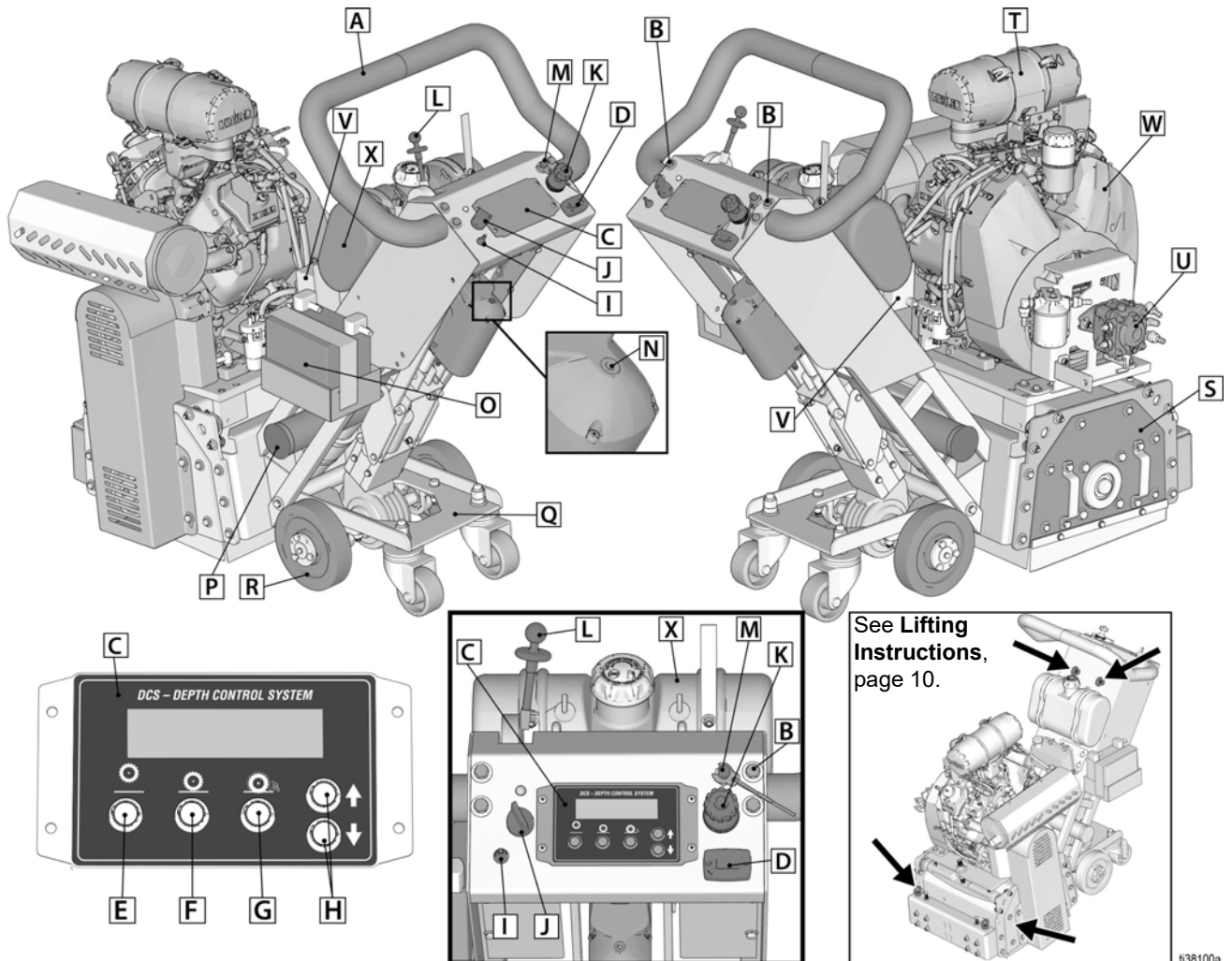

Component	
A	Adjustable Handlebar
B	Handlebar Adjustable Bolts
C	DCS Control
D	Hour Meter / Tachometer
E	Home Button
F	Zero Button
G	Cut Depth Button
H	Up / Down Button
I	DCS Power Switch
J	Key Switch
K	Throttle Control
L	Forward / Reverse Control Lever

Component	
M	Engine Kill Button
N	Manual Height Adjustment
O	Battery
P	Vacuum Port
Q	Lift Carriage with Swivel Casters
R	Self-Propelled Drive Wheels
S	Removable Side Plate
T	Air Intake / Filtration System
U	Hydraulic Drive Pump
V	Hydraulic Reservoir
W	Engine (Kohler)
X	Gas Tank

FS351 P DCS (Propane)

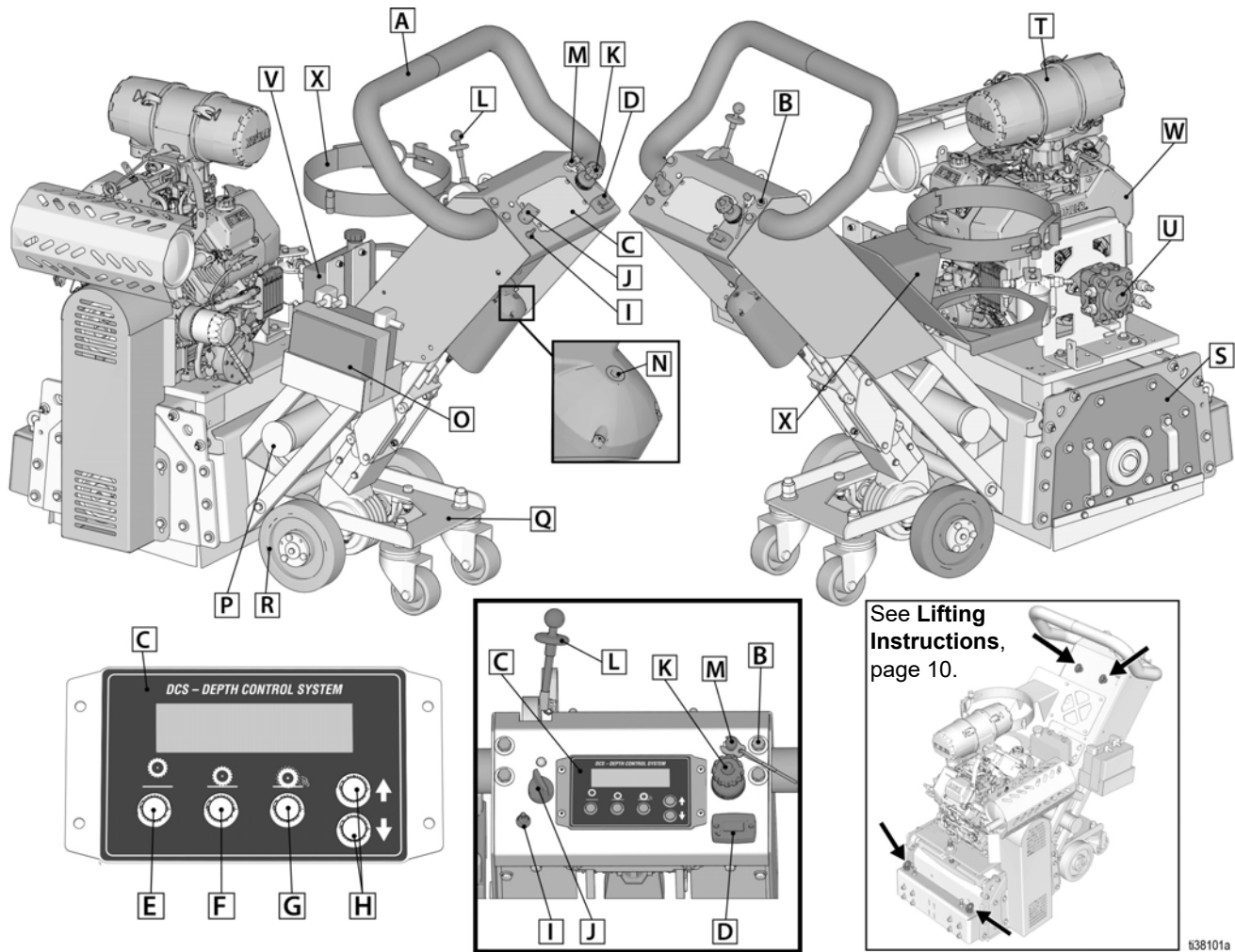

138101a

Component	
A	Adjustable Handlebar
B	Handlebar Adjustment Bolts
C	DCS Control
D	Hour Meter / Tachometer
E	Home Button
F	Zero Button
G	Cut Depth Button
H	Up / Down Button
I	DCS Power Switch
J	Key Switch
K	Throttle Control
L	Forward / Reverse Control Lever

Component	
M	Engine Kill Button
N	Manual Height Adjustment
O	Battery
P	Vacuum Port
Q	Lift Carriage with Swivel Casters
R	Self-Propelled Drive Wheels
S	Removable Side Plate
T	Air Intake / Filtration System
U	Hydraulic Drive Pump
V	Hydraulic Reservoir
W	Engine (Kohler)
X	Propane Tank Bracket

Setup

Propane Tank

Propane (LP gas) supply tank not provided by SMITH. Supply tank must be vertically mounted and vapor withdrawal type. Supply tank must be designed, fabricated, and marked in accordance with specifications and regulations for LP-Gas cylinders at: The U.S. Department of Transportation (DOT); the National Standard of Canada, CAN/CSA-B339, Cylinders, Spheres, and Tubes for Transportation of Dangerous Goods; the Transportable Pressure Vessels Regulations 2001 (S1 2001/1426); or the Gas Cylinders (Pattern Approval) Regulations 1987 (SI 1987/116)(Pattern Approval Regulations) for EEC-type cylinders under European Directive 84/525/EEC, 84/526/EEC, and 84/527/EEC.

Check gas supply hose connection to propane cylinder. Make sure fitting is free of debris before connecting to tank. Make sure gas connection is screwed completely on and is free of leaks.

NOTE: The propane tank connection hose is equipped with a POL gas fitting. If a different sized fitting is needed, see your local LP gas equipment supplier.

Lifting Instructions

- Only lift the equipment using all available lift points. The lift chains must be angled at least 45° from the horizontal.
- Lift the system with a lift apparatus rated appropriately for the weight of the system. See **Technical Data**, page 72.
- Lift the system using the lift eyes shown on the appropriate illustration.

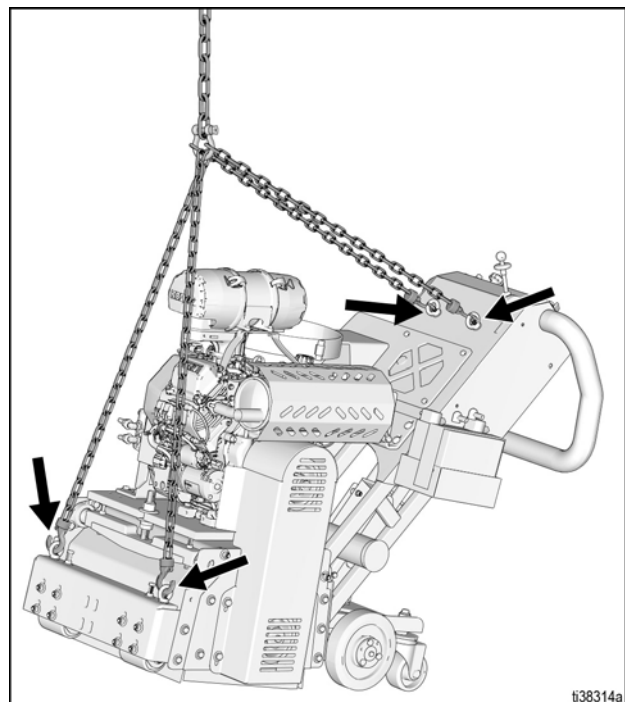

Handlebar Adjustment

The handlebars are equipped with a high-density vibration suppression material to reduce operator fatigue. To adjust the handlebars to a new position for different height operators, please follow these steps:

1. Using a 9/16" wrench or socket, loosen the bolts on both sides of the handlebars until the handlebar moves freely.

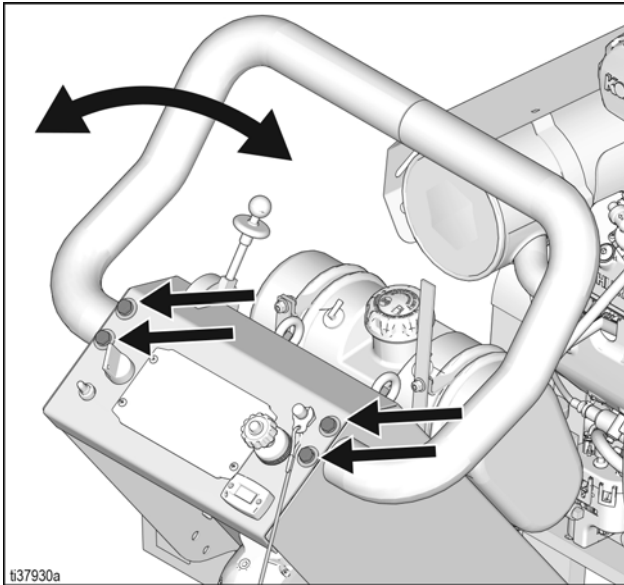

2. Stand behind the machine and lightly tap the handlebar to the desired position.
3. Re-tighten the bolts to 260-300 in-lb (29-34 N•m) to lock the handlebars into position.

NOTE: Never operate equipment with loose handlebars. The bolts must be fastened tightly to ensure the handle is locked into position.

Engine Kill Button (Gas/Propane)

In the event of a malfunction or an accident (such as the machine operator falling or losing footing), the FS351 is equipped with a corded Engine Kill Button. Attach the end of the cord to the operator's belt or wrist, and snap the clip into place on the button by raising the top of the Engine Kill Button and inserting the clip into the gap. If the operator becomes distanced too far from the machine, the cord will detach from the button and the machine will stop running. The engine can also be stopped by pressing down on the Engine Kill Button.

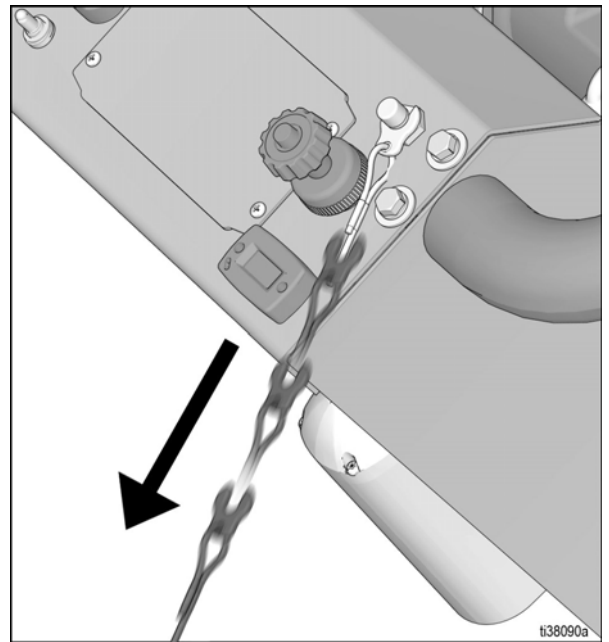

Drum Installation/Replacement



Gas/Propane: To avoid injury from unexpected start up, turn ignition OFF, remove key, and disconnect spark plug wires before you service your unit.
Electric: To avoid injury from unexpected start up, disconnect power plug before servicing your machine.

Normal use will require periodic drum inspection and may necessitate drum replacement. Time of replacement will vary according to usage and load factors.

Tools needed:

- 9/16" socket or wrench
- Rubber mallet
- 1-1/8" wrench

1. Turn DCS Power Switch ON. Wait until the FS351 cools off if it has been running.
2. Press Home Button on DCS Control to raise the cutter drum off the work surface.



Once at home position, disconnect negative (-) battery cable for gas/propane units. For electric units, disconnect power plug. If more adjustment is needed at this point, use the **Manual Height Adjustment**, page 20.

3. Using 1-1/8" and 9/16" wrench, lower jam nuts and support bolts on engine/motor plate so that tension is released off belt.

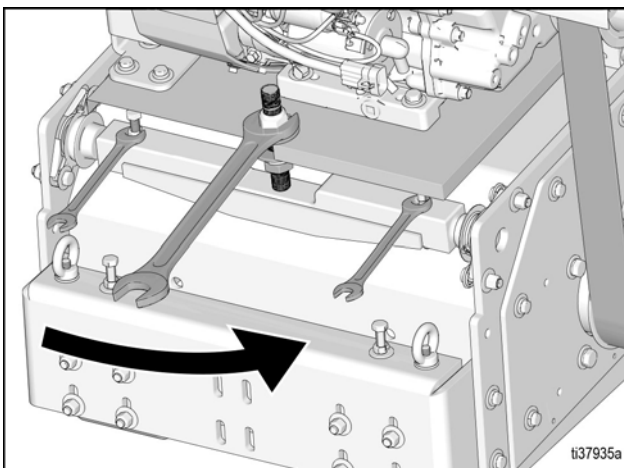

4. Remove six hex head cap screws from the Side Plate using the 9/16" socket or wrench.
5. Remove the Side Plate (this may require the rubber mallet to break it loose).
6. Slide out the drum assembly. Use caution as the assembly is heavy.

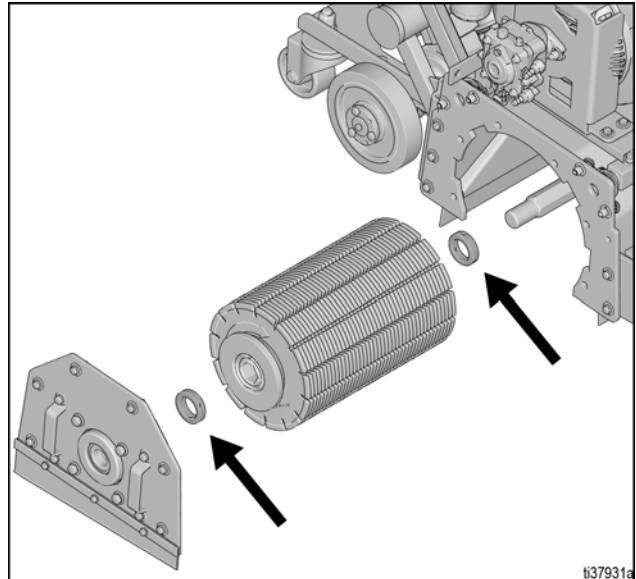

7. Before replacing the drum onto hex shaft:
 - a. Check that all bearings are in good working order.
 - b. Remove dirt and material build-up from inside main housing and drum.
 - c. Apply grease to all metal contacts.
 - d. Check drum spacers for wear, replace if necessary (if applicable).
8. Align and slide drum back onto the hex shaft.
9. Replace Side Plate (slide onto) hex shaft and reinstall the six cap screws and torque to 40 ft/lbs (54.2 N•m). Check that drum moves side to side and drum spacers are free to move (if applicable).
10. To tension the belt, turn the base plate pivot nut with the 1-1/8" wrench. This will raise the engine/motor base plate. Use the 9/16" wrench to raise bolts into place, locking jam nut when complete.

NOTE: An extra drum loaded with cutters for rapid job site replacement is recommended.

DCS Control

Buttons on the DCS Control have two functions, quick press and long press. Quick press refers to pressing the button and releasing the button quickly, while long press is pressing the button and holding the button for two or more seconds.

NOTE: "+" (plus) refers to above work surface. "-" (minus) refers to below work surface.

Run Screen

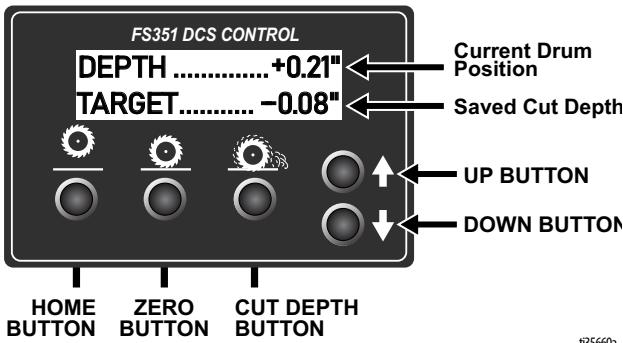

ti3560a

Home Button

Quick Press: Takes the drum to its highest position.



ti3561a

Long Press: Brings up Menu Screen.

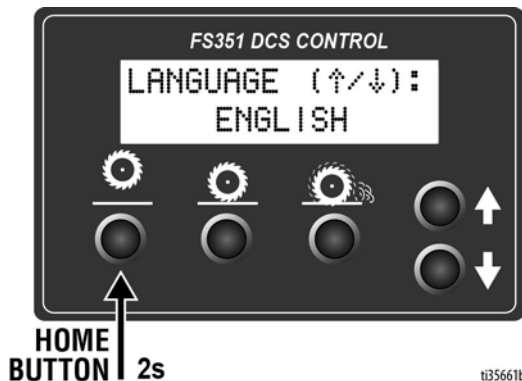

ti3561b

Zero Button

Quick Press: Takes the drum to the work surface.

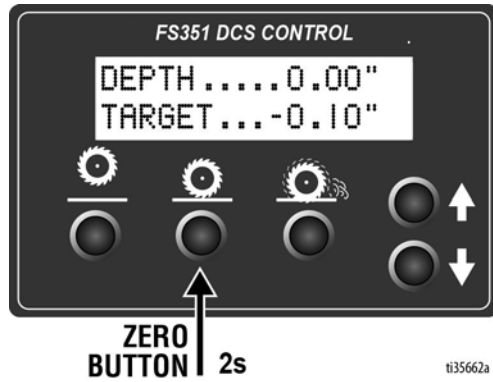

ti3562a

Long Press: Reprograms the zero point to the current drum position.

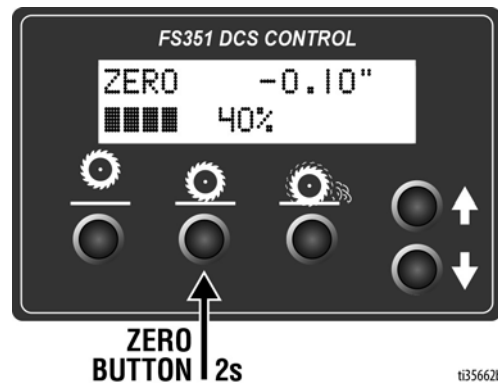

ti3562b

Cut Depth Button

Quick Press: Takes the drum to the Cut Depth Target.

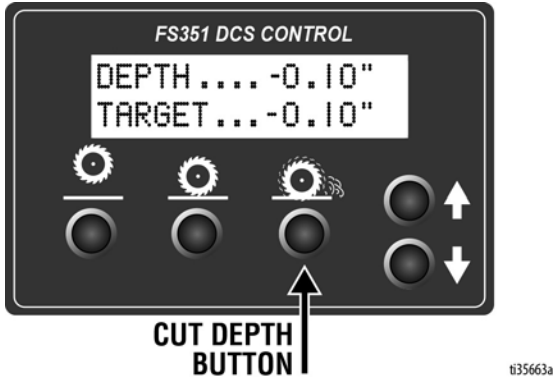

Long Press:

- If at or above zero point: Opens new screen to select desired cut depth using up/down buttons.
- To exit without saving, quick press the Cut Depth Button.
- To exit with saving, long press the Cut Depth Button.
- If below zero point: Reprograms the Cut Depth Target to the current drum position.



Up Arrow Button*

Quick Press: Raises the drum by 0.01" (0.25mm, 10 mil).



Long Press: Raises the drum to Home position.



Down Arrow Button*

Quick Press: Lowers the drum by 0.01" (25mm, 10 mil).

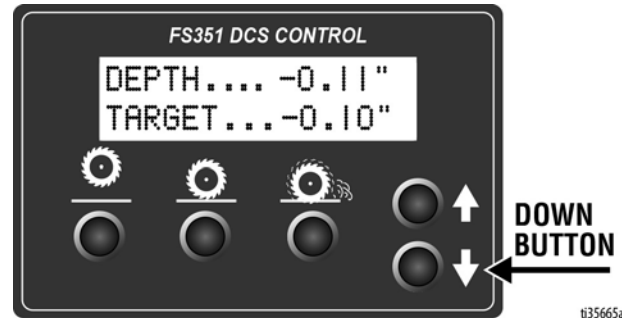

Long Press: Lowers the drum to Cut Depth Target.



* Handlebar Rocker Switch has the same functions as Up and Down Arrow Buttons.

Menu Screens

To display the Menu Screens, hold down Home Button from the Run Screen. To save menu settings and return to Run Screen, hold down Home Button from any Menu Screen.

To cycle through selections in each Menu Screen, use Up and Down Arrow Buttons.

To advance to next Menu Screen, quick press the Home Button.

Menu Screen #1 - Language

Select your desired language (English, Spanish, French, German, or International Symbols).

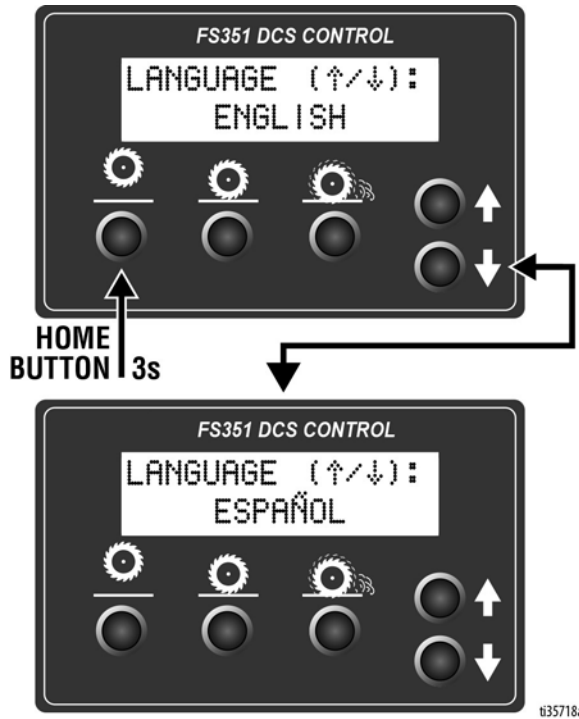

Menu Screen #2 - Units

Select your desired depth units (inches, millimeters, or mils).

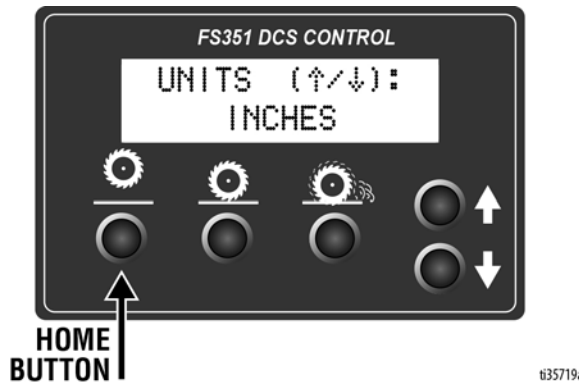

Menu Screen #3 - Model Select

Your FS351 model name can be found on the handlebar dashboard label. Select the model on the DCS Control which matches the model you have. This ensures accurate depth readings. Hold down Up or Down Arrow Buttons to cycle through models.

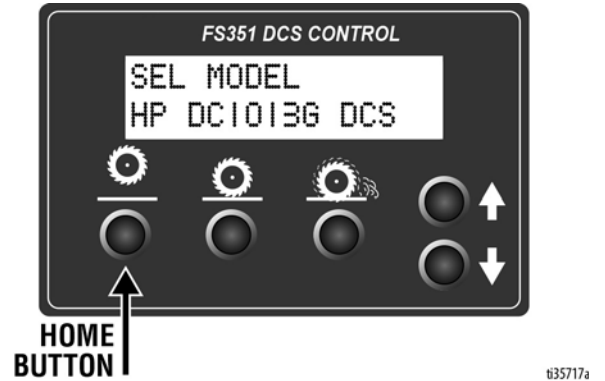

Menu Screen #4 - Software revision

Displays the revision of the software on the DCS Control.

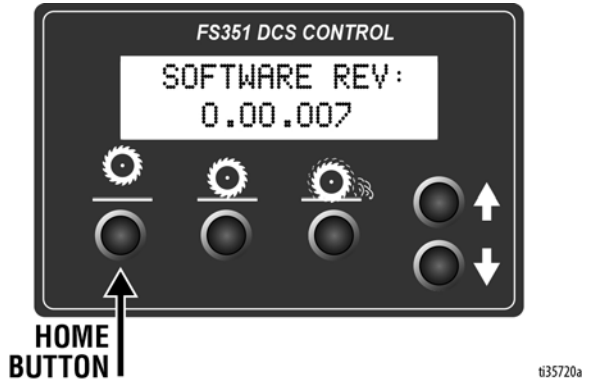

Menu Screen #5 - Error Codes

Displays the most recent error code and the total number of times that error has occurred. Cycle through previous error codes using Up/Down Buttons.

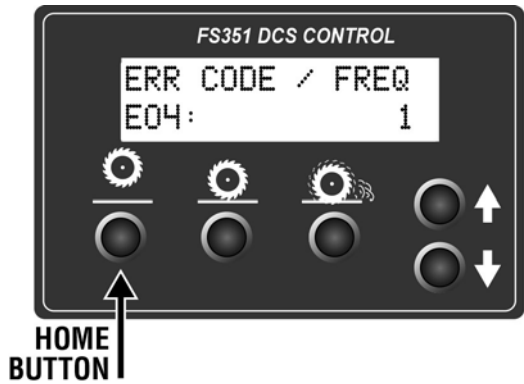

Error Codes

- E04: High Voltage
- E05: High Motor Current
- E08: Low Voltage
- E09: Hall Sensor Error
- E12: High Current (short circuit)
- E31: Home Button Error
- E32: Zero Button Error
- E33: Cut Depth Button Error
- E34: Up Button Error
- E35: Down Button Error

To clear an error code that appears while on the Run Screen:

1. Turn DCS Power Switch OFF.
2. Address/Fix the issue.
3. Turn DCS Power Switch ON.

NOTE: See Repair Manual for more information on Error Codes and Troubleshooting.

Operation

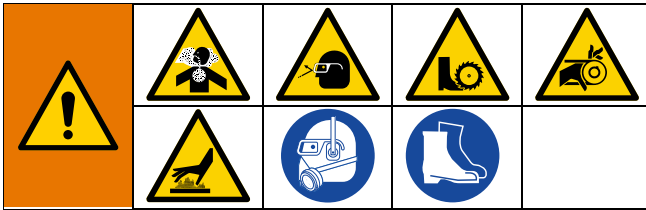

Do not start machine while cutter head is in contact with the work surface. Doing so can cause the operator to lose control of the machine, resulting in property damage and/or personal injury.

Electric: To avoid injury from unexpected movement, ensure Power Switch is in the OFF position before connecting or disconnecting the power cord. In the event of a power failure or interruption, ensure Power Switch is on the OFF position before restoring power.

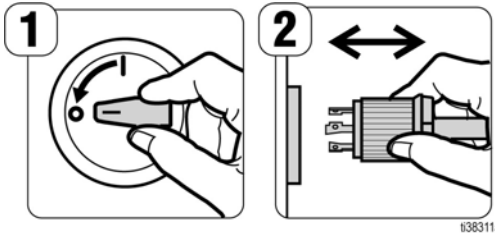

Machine Start Up (Gas & Propane)

1. Turn DCS Power Switch ON.
 2. Verify the Forward/Reverse Control Lever is in the neutral (N) position.
 3. Place the throttle lever at the “fast idle” position.
 4. Start the engine.
 5. Move throttle control to open or run position when engine is warmed up.
 6. Increase throttle to optimal machine operating position.
- NOTE:** Engine speed for all drum assemblies is 3450 RPM.
7. Before removal, run the drum with the cutters not touching the work surface. If there is excessive vibration, re-balance the cutter setup, check bearing condition, and/or make sure the drive shaft is secured.

If the Engine Does Not Start

- Turn the ON/OFF Switch on the Control Panel to ON.
- Check engine for proper gas and oil levels.
- Check the spark plug. Make sure socket areas are clean and clear of debris, and the proper gap is set. Replace if needed.
- Check the corded Engine Kill Button’s connections. Make sure the corded safety stop “C” connector is properly inserted into the Engine Kill Button.

Machine Start Up (Electric)



NOTICE
<p>Make sure motor is rotating in the correct direction. Look for clockwise rotation on the right side of the machine at drum end shaft by turning on and off quickly. Incorrect rotation will damage hydraulic pump and could damage cutters if contact is made with the work surface. If rotation is incorrect, exchange positions of two power wires at the plug. Do not loosen or move the ground wire at the plug.</p>

1. Turn motor ON/OFF switch to **OFF**.
2. Verify the Forward/Reverse Control Lever is in the neutral (N) position.
3. Plug the machine in to the electrical source.
4. Turn motor ON/OFF switch to **ON**.
5. Before operating, run the drum with the cutters not touching the work surface. If there is excessive vibration, re-balance the cutter setup, check bearing condition, and/or make sure the drive shaft is secured.

If the Motor Does Not Start

- Make sure the motor is plugged into the electrical source.
- Turn motor ON/OFF switch to ON.

When operating...

				
<p>SEVERE ELECTRIC SHOCK HAZARD Electric: Keep the extension cord clear of machine travel path</p>				

Adjust the height of the cutter drum. Set the depth of cut to allow the cutters to go through only the materials to be removed. Make certain that the drum is positioned to where only the cutters strike the work surface, and that the drum assembly never comes in to contact with the work surface. **The cutter tips alone should strike the work surface** (1/8" to 1/4" maximum depth per removal pass on new cutters). The drum will not survive work surface contact.

NOTICE

Cutting too deep will cause premature wear to cutters, shafts, drum and other components.

Remove materials in several passes rather than one deep pass. Several tests will show the best, most appropriate cutter depth. Use a forward/backward pattern to achieve your desired finish.

When the job is complete, or the operator wants to cease work, raise the drum above the work surface by pressing home button on DCS control.

- **For gas units**, stop the machine with the key switch or power switch.
- **For propane units**, stop machine with the key switch or power switch, then close the propane supply valve.
- **For electric units**, stop machine by turning motor power switch OFF, and unplug the machine from the electrical source.

The drum assembly must be removed daily and inspected for drum wear, hole elongation and possible weld separation. Replace the cutter shafts every 40 hours, or prior to any drum wear. If the drum's center holes are elongated, order another SMITH cutter drum.

Hydrostatic Drive Operation

Engine/motor must be warmed up and at desired speed.

Verify the Forward/Reverse Control Lever is in the neutral (N) position. Lower the unit to raise the carriage wheels off the work surface and set the unit onto the drive wheels. The Forward/Reverse Control Lever should be in the neutral (N) position and the wheels should not be turning. At this point the unit can be propelled forward or reverse by pressing down on the Control Lever and moving the Control Lever either forward or backward.

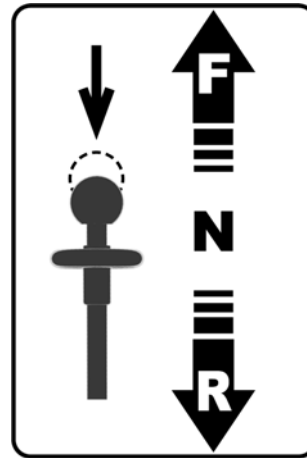

The "live" axle will help move the unit in a straight line. However, keep both hands on the handle for safe operation and minor directional corrections.

DCS Instructions

Each time the DCS Control is turned on, the DCS actuator will travel to the Home position.



Once the DCS Control finds Home, ensure the correct model is selected as well as your desired language and units. See **Menu Screens**, page 15, for instructions on changing these settings.

Set Zero Point:

With the engine/motor on, lower the drum by pressing the Down Arrow Button until you hear the cutters make contact with the work surface. Hold down the Zero Button for 2 seconds. Your Zero Point has now been saved.

NOTE: The Cut Depth Target is based off of the Zero Point. Re-program the Zero Point if the drum is changed or worn.



Set Cut Depth Target:

Quick press the Zero Button to take the drum to the work surface. Set the Cut Depth Target by:

1. Quick pressing the Down Arrow Button as many times as needed to achieve your target. Then long press the Cut Depth Button to save your target.

NOTE: This method will lower the cutting drum into the work surface as you set your cut depth.

OR

2. From the Zero Point, long press the Cut Depth Button until a new screen pops up. Use the Down Arrow Button to enter your Cut Depth Target. Then long press the Cut Depth Button to save your target and return to the Run Screen.

NOTE: This method will keep the cutting drum stationary as you set your Cut Depth Target.

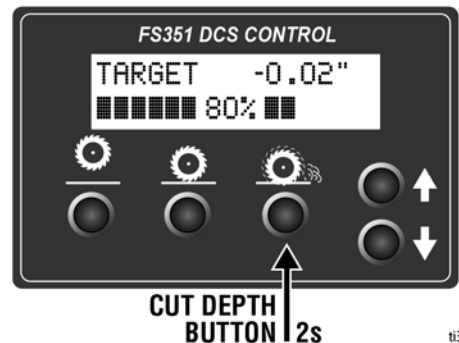

The DCS Control is now ready to grind/scarify.

NOTE: The Zero Point and Cut Depth are referenced from the Home position. Recalibrate your DCS Control periodically by pressing the Home button.

NOTE: Pressing any button while the drum is moving to Zero or Cut Depth will stop the command and halt the drum from moving any further up or down until another button is pressed.

Manual Height Adjustment

If the DCS Control is not usable (dead battery, etc.), the drum height can be adjusted using the Manual Height Adjustment feature.

1. Remove fuse from fuse holder near positive battery terminal. This will protect the battery from damage.

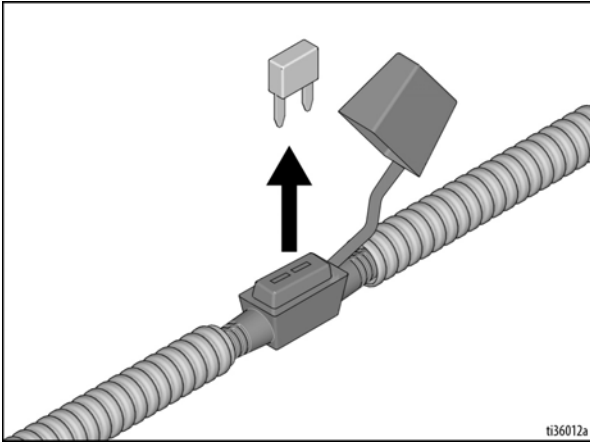

2. Use a 6mm hex key to remove the screw plug on the top of the linear actuator.

3. Insert 6mm hex key into the port the screw plug was removed from.
 - One revolution of the hex key results in 1/16" (1.6 mm, 62.5 mil) of adjustment at the cutter drum.
 - Rotate counterclockwise to raise the drum; rotate clockwise to lower the drum.

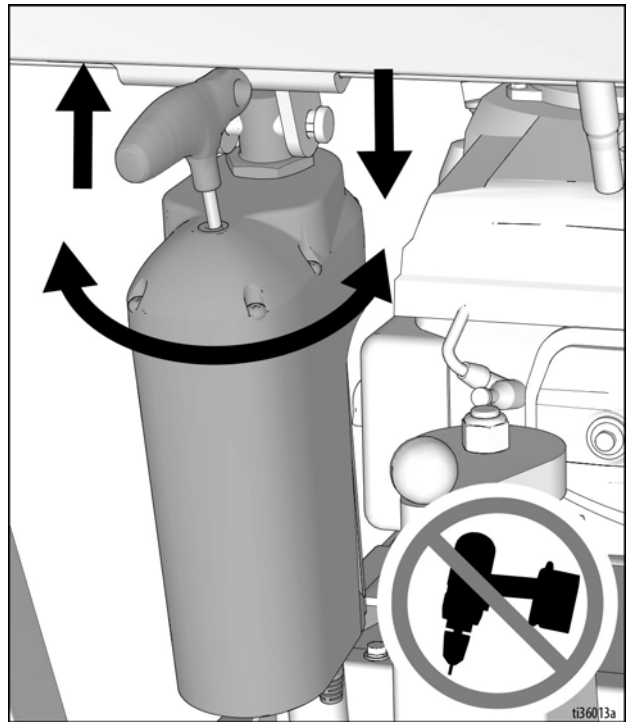

NOTICE

Max rotation speed is one revolution per second. Do not use power tools in the Manual Height Adjustment port. Doing so will cause damage to the actuator.



4. Once the desired depth is achieved, replace the screw plug in order to keep water and dust out.

Repair

				
---	---	---	--	--

Gas/Propane: To avoid injury from unexpected start up, disable engine as follows: 1) Turn DCS Power Switch OFF. 2) Turn ignition OFF. 3) Disconnect spark plug wires. 4) Disconnect negative (-) battery cable from battery.

Electric: To avoid injury from unexpected start up, disconnect power plug before you service your machine.

Electric: To avoid injury from unexpected movement, ensure Power Switch is in the OFF position before connecting or disconnecting the power cord.

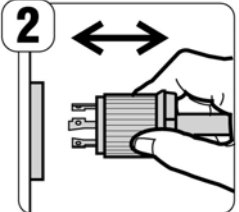
i38311a

Drive Belt Replacement

Normal wear will require periodic belt tensioning and replacement. Time of replacement will vary according to usage and belt load factors.

Tools needed:

- 9/16" socket or wrench
- 1-1/8" open box wrench
- Straight edge or ruler

1. Wait until the FS351 cools off if it has been running.
2. Make sure the Removable Side Plate is installed. This ensures the drive ends are in proper position for servicing.

3. Clean the exterior of the machine so you can locate all of the appropriate parts.
4. Using a 9/16" socket or wrench, remove the four hex bolts attaching the belt cover to the side of the machine. Remove the cover and set aside.

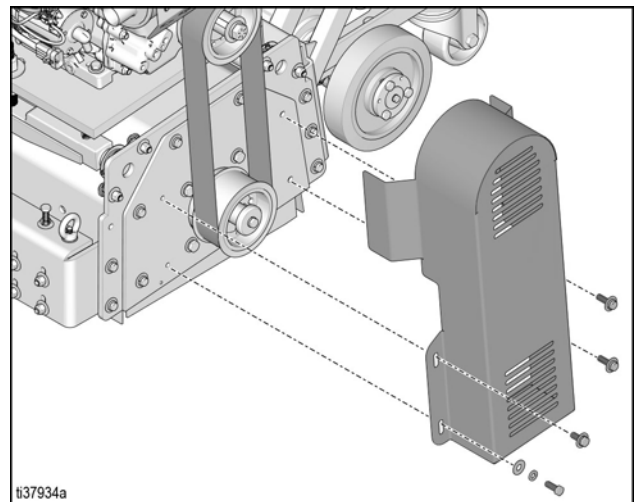

5. Turn the lower base plate pivot nuts clockwise with the 1-1/8" wrench to lower the engine/motor base plate. Use 9/16" wrench to lower the two bolts on either side and loosen the drive belt. Remove or replace the belt as needed.

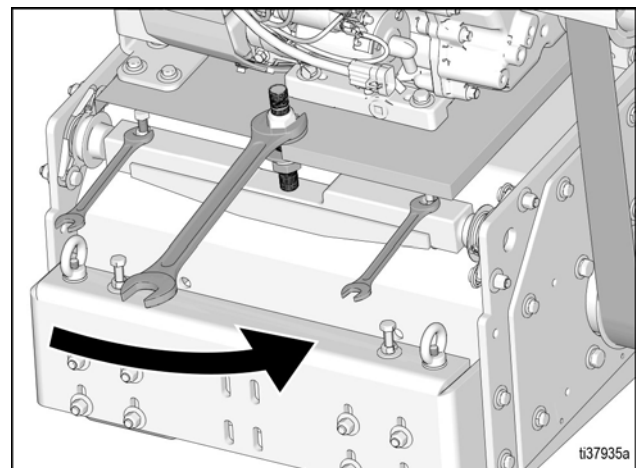

6. To tension the belt, turn the base plate pivot nut with the 1-1/8" wrench. This will raise the engine/motor base plate. Use a 9/16" wrench to raise bolts into place, locking jam nut when complete.

NOTICE

Ensure belts are aligned using straight edge or ruler prior to operation. Do not over-tighten the belt as this will cause premature wear to the belt.

- Put the belt cover back in place and secure the four hex nuts with the 9/16" socket or wrench.

Unit	Deflection Force	Deflection Distance
Electric	11 lbs	1/4"
Gas	16 lbs	1/4"
Propane	12 lbs	1/4"

Hydraulic Belt Replacement (Electric Models only)

Normal wear will require periodic belt tensioning and replacement. Time of replacement will vary according to usage and load factors.

Tools needed:

- 9/16" socket or wrench
- Straight edge or ruler

- Wait until the FS351 cools off if it has been running.
- Follow instructions on previous page to remove belt cover, drive belt, and drive pulley,
- With the guard cover off, use the 9/16" socket or wrench to release tension to the belt by loosening (do not remove) the two hex bolts holding the hydraulic pump support bracket. Replace the belt as needed.

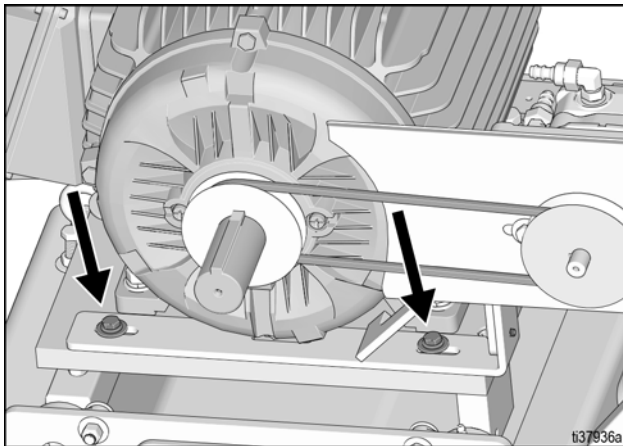

- To tighten the belt, slide the bracket up and lightly tighten the hex bolts. To ensure alignment of the pulleys, use a ruler or a straight edge and place it on the faces of both pulleys and adjust the bracket accordingly. Verify alignment from the front of the machine. Once properly aligned, tighten the bolts.

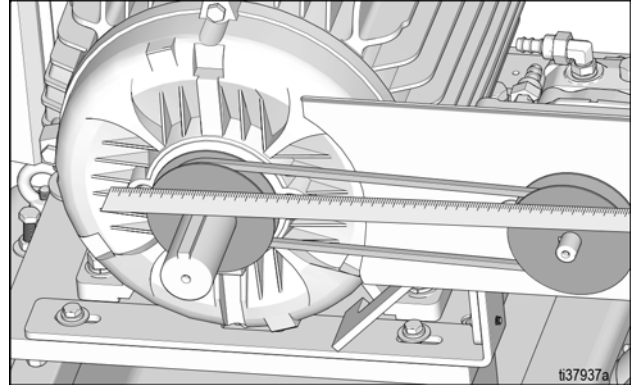

- Follow instructions on previous page to attach belt cover, drive belt, and drive pulley.

Bearing Housing Replacement

Tools needed:

- 17mm socket or wrench
- 9/16" socket or wrench
- Adjustable wrench up to 1.5"
- 7/32" hex key
- Retaining ring pliers

1. Follow **Drum Installation/Replacement**, page 12, to remove the drum.
2. Follow **Drive Belt Replacement**, page 21, to remove the drive belt from the machine.
3. Wait until the FS351 cools off if it has been running.
4. With the Side Plate off the machine, use a wrench to lock the rotation of the shaft. Using the 9/16" socket or wrench, remove the screw that holds the bushing to the shaft.

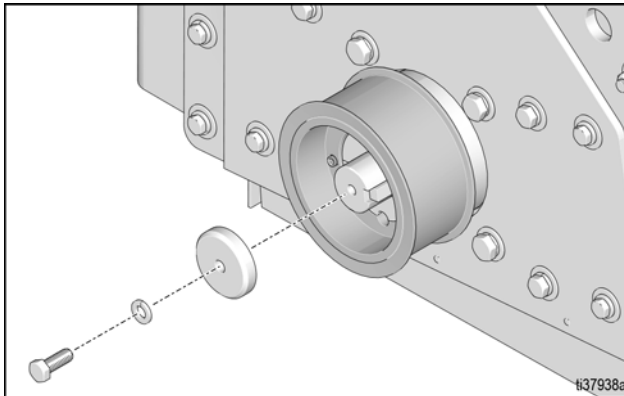

5. With the shaft rotation locked, use the 7/32" hex key to remove the two set screws on the drive pulley. Once removed, insert one of the set screws into the hole directly above the keyway to back out the bushing. Remove the bushing and pulley.

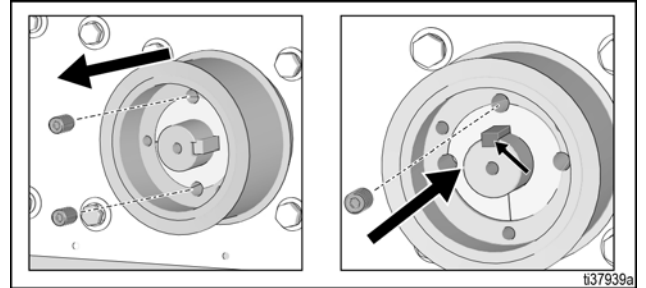

6. With the pulley removed, use retaining ring pliers to remove retaining ring on shaft. Use the 17mm socket or wrench to remove the bearing housing assemblies from the frame and from the Side Plate.

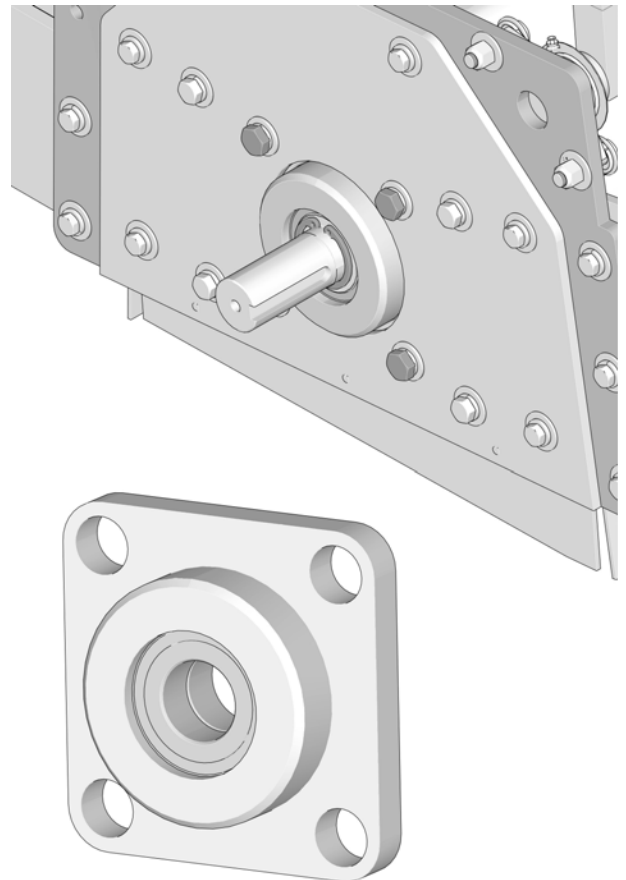



7. Reverse steps to reassemble bearing housing.
NOTE: Replace the rubber spring elements at this time.

Drive Pulley Replacement

The drive pulleys must be replaced to change between high speed and standard speed.

Before changing the drive pulleys, follow **Drive Belt Replacement** or **Hydraulic Belt Replacement (Electric Models only)**, page 22, to remove and replace the belt cover, drive belt, and drive pulleys from the machine.



				
Flail drums must be used only on standard speed machines. Using flail drums on high speed machines will damage the drum and may cause serious injury.				

Gas/Propane Models

Standard Speed: Use the 28-tooth pulley on the engine shaft and the 56-tooth pulley on the drum shaft. Use the 1120 mm belt.

High Speed: Use the 48-tooth pulley on the engine shaft and the 48-tooth pulley on the drum shaft. Use the 1160 mm belt.

For parts diagrams, see **Parts - Pulley Assemblies (Gas)**, page 48, and **Parts - Pulley Assemblies (Propane)**, page 56.

	28T 56T	CARBIDE/ ✓ STEEL FLAIL	PCD/ ✗ DIAMOND
	48T 48T	CARBIDE/ ✗ STEEL FLAIL	PCD/ ✓ DIAMOND



19B331C

Electric Models

Standard Speed: Use the 48-tooth pulley on the motor shaft and the 56-tooth pulley on the drum shaft with the 1200 mm belt.

High Speed: Use the 64-tooth pulley on the motor shaft and the 34-tooth pulley on the drum shaft with the 1160 mm belt.

For parts diagrams, see **Parts - Pulley Assemblies (Electric - 480V & 380V)**, page 66.

	56T 48T	CARBIDE/ ✓ STEEL FLAIL	PCD/ ✗ DIAMOND
	64T 34T	CARBIDE/ ✗ STEEL FLAIL	PCD/ ✓ DIAMOND

19B325B

Maintenance Checklist



Gas/Propane: To avoid injury from unexpected start up, disable engine as follows: 1) Turn DCS Power Switch OFF. 2) Turn ignition OFF. 3) Disconnect spark plug wires. 4) Disconnect negative (-) battery cable from battery.

Electric: To avoid injury from unexpected start up, disconnect power plug before you service your machine.

Electric: To avoid injury from unexpected movement, ensure Power Switch is in the OFF position before connecting or disconnecting the power cord.

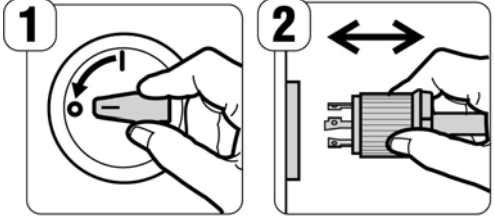

Gas/Propane Models only

- Check heavy-duty air cleaner element.

Gas Models

- **Weekly:** Check filter minder.
- ***Every 150 Hours:** Check heavy-duty air cleaner element.
- **Every 300 Hours:** Replace heavy-duty air cleaner element and check inner element.
- **Every 600 Hours:** Replace heavy-duty inner air cleaner element.

Propane Models

- ***Every 150 Hours:** Check heavy-duty filter minder. Inspect heavy-duty air filter paper element and inlet screen area.
- ***Every 300 Hours:** Replace heavy-duty air cleaner element and check inner element.
- ***Every 600 Hours or Yearly:** Replace heavy-duty inner air cleaner element.

* Perform these procedures more frequently under severe, dusty, dirty conditions.

- Maintain proper engine oil and crankcase levels. Change every 25-50 hours (see Kohler manual).
- Clean spark plugs regularly, and set the proper gap (see Kohler manual).

All Models

- Keep a coating of grease on the drive shaft and threads for easy installation or removal, and for longer hex bushing life.
- During oil changes or routine maintenance, check all fasteners and re-tighten, since the machine will vibrate the fasteners loose if they are not secured. Use medium strength thread locking compound.
- Check the Drive and Hydraulic belts for wear, and adjust tension (page 22) or replace as needed. After replacing belts, check for proper tension.
- Check to ensure the pulleys are aligned properly to ensure the Drive and Hydraulic belts are running true.
- The inside housing must be clean. Remove build-up from inside the cage so cutters and drum rotate freely.
- Inspect and change drum bushings and shafts every 40 hours, or when worn.
- Ensure hydraulic fluid level reservoir is filled to the proper level and inspect fittings for leaks. Tighten as necessary. For accurate level readings, take readings when fluid is cold.

The hydraulic fluid for the hydraulic drive pump should be chemically stable and incorporate rust and oxidation inhibitors.

Specific fluid type meeting these requirements: ISO 68 Synthetic Oil or 15W50 Synthetic Oil.

Purge Procedures

Due to the effects air has on efficiency in hydrostatic drive applications, it is critical that air is removed or purged from the system.

NOTE: These procedures must be performed anytime a hydrostatic system has been opened for maintenance or repair, or if any additional hydraulic fluid has been added to the system.

Air creates inefficiency because it has compression and expansion rates that are higher than that of hydraulic fluid. Air trapped in the hydraulic fluid may cause the following symptoms:

1. Noisy operation.
2. Lack of power or drive after short-term operation.
3. High operation temperature and excessive expansion of hydraulic fluid.

Before starting purge procedure, make sure the reservoir is at the proper oil level. If it is not, fill to top of tank baffle.

The following procedures should be performed with the drive wheels off the ground, then repeated under normal operating conditions.

1. With the bypass valve open and the engine/motor running, slowly move the directional control in both forward and reverse directions 5 to 6 times. As air is purged from the unit, the hydraulic fluid level in the reservoir will drop.

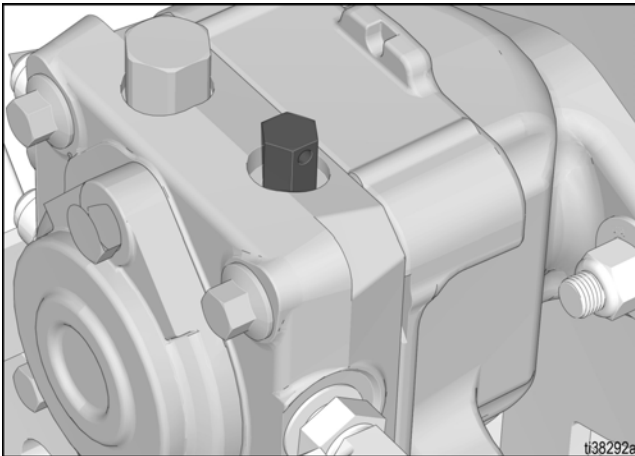

2. With the bypass valve closed and the engine/motor running, slowly move the directional control in both forward and reverse directions 5 to 6 times. Check the oil level, and add hydraulic fluid as required after stopping engine/motor.
3. It may be necessary to repeat steps 1 and 2 until all the air is completely purged from the system. When the drive wheels move forward and reverse at normal speed, and the reservoir hydraulic fluid remains at a constant level, purging is complete.

Front Wheel Adjustment

The front wheels can be adjusted independently.

1. Loosen, but do not remove the four nuts holding the wheel to be adjusted.

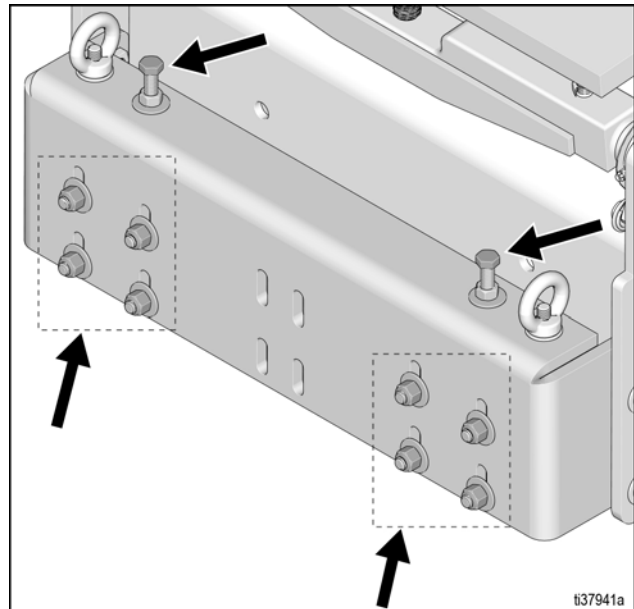

2. Adjust wheel height as needed using height adjustment bolt.
3. Tighten all nuts to secure wheel into position. Torque to 23-27 ft-lbs (31.2-36.6 N•m).

Recycling and Disposal

Rechargeable Battery Disposal

Do not place batteries in the trash. Recycle batteries according to local regulations. In the USA and Canada, call 1-800-822-8837 to find recycling location or go to www.call2recycle.org.

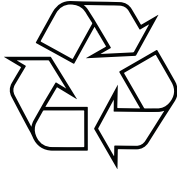





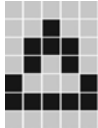
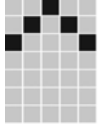
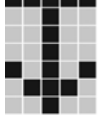
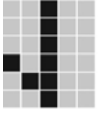
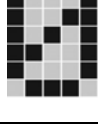

End of Product Life

At the end of the product's useful life, dismantle and recycle it in a responsible manner.

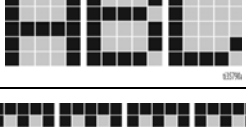
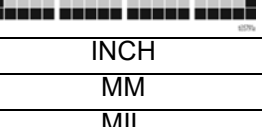

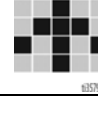
- Drain and dispose of fluids according to applicable regulations. Refer to the material manufacturer's Safety Data Sheet.
- Remove motors, batteries, circuit boards, LCDs (liquid crystal displays), and other electronic components. Recycle according to applicable regulations.
- Do not dispose of electronic components with household or commercial waste. 
- Deliver remaining product to a recycling facility.

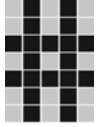
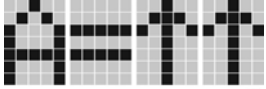
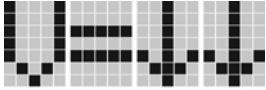
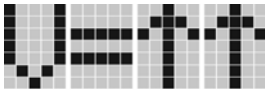
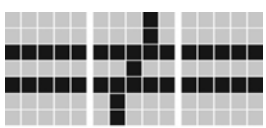
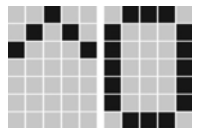
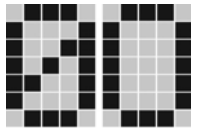
DCS Control Translations

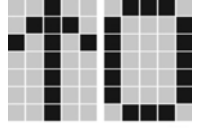
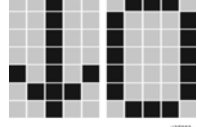
English	Español	Français	Deutsche	International
FINDING HOME	ENCONTRANDO INICIO	TROUVER LE DÉBUT	START FINDEN	
HOME	INICIO	DÉBUT	START	
DEPTH	ALTURA	HAUTEUR	TIEFE	
TARGET	OBJETIVO	OBJECTIF	ZIEL	
ZERO	CERO	ZÉRO	NULL	
SEL MODEL	MODELO	MODELE	MODELL	
LANGUAGE	IDIOMA	LA LANGUE	SPRACHE	
UNITS	UNIDAD DE MEDIDA	UNITÉ DE MESURE	MAßEINHEIT	
INCHES	PULGADAS	POUCES	ZOLL	INCH
MILLIMETERS	MILIMETROS	MILLIMETRES	MILLIMETER	MM
MILS	MILS	MILS	MILS	MIL
SOFTWARE REV	SOFTWARE REV	REVUE SOFTWARE	SOFTWARE REV	
ERROR	ERROR	ERREUR	FEHLER	

English	Español	Français	Deutsche	International
FREQUENCY	FRECUENCIA	FRÉQUENCE	ANZHAL	 63579a
HIGH CURRENT	ALTA CORRIENTE	COURANT ÉLEVÉ	HOHER STROM	 63579a
LOW VOLTAGE	BAJO VOLTAJE	BASSE TENSION	NIEDERSPANNUNG	 63579a
HIGH VOLTAGE	ALTO VOLTAJE	HAUTE TENSION	HOCHSPANNUNG	 63579a
HALL SENSORS	SENSORES DE HALL	CAPTEURS DE HALL	HALL-SENSOREN	 63579a
HOME BUTTON	BOTÓN DE INICIO	BOUTON DE DÉBUT	START KNOPF	 63579a
ZERO BUTTON	BOTÓN CERO	BOUTON ZÉRO	NULLTASTE	 63580a
CUT BUTTON	BOTÓN DE CORTAR	BOUTON DE COUPE	SCHNITT TASTE	 63580a
UP BUTTON	BOTÓN ARRIBA	BOUTON HAUT	NACH OBEN TASTE	 63580a
DOWN BUTTON	BOTÓN DE ABAJO	BOUTON BAS	NACH UNTEN TASTE	 63580a

Troubleshooting

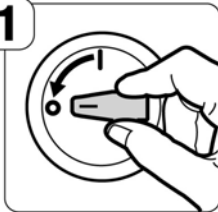
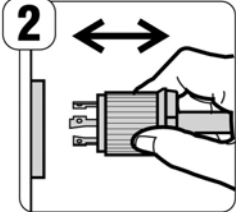
			
<p>Gas/Propane: To avoid injury from unexpected start up, disable engine as follows: 1) Turn ignition OFF. 2) Disconnect spark plug wires. 3) Disconnect negative (-) battery cable from battery.</p> <p>Electric: To avoid injury from unexpected start up, disconnect power plug before you service your machine.</p> <p>Electric: To avoid injury from unexpected movement, ensure power switch is in the OFF position before connecting or disconnecting the power cord. In the event of a power failure or interruption, ensure Power Switch is in the OFF position before restoring power.</p>			
<div style="display: flex; justify-content: space-around; align-items: center;"> <div style="text-align: center;"> <p>1</p>  </div> <div style="text-align: center;"> <p>2</p>  </div> </div> <p style="text-align: right; font-size: small;">038311a</p>			

Problem	Cause	Solution
Cutters wearing unevenly/prematurely	Cutter head is too low	Raise the cutter head
	Material build up	Clean the cutters
	Bearings may be worn	Replace bearings
	Wrong cutters for application	Contact Tech Services
Cutters Shaft Breakage unevenly/prematurely	Cutter head is too low	Raise the cutter head
	Over 40 hours service life	Replace shafts
Drum wearing prematurely or cracking	Drum hitting work surface	Raise the drum
	Shafts and bushings not replaced within 40 hours	Replace shafts and bushings
Excess Vibration	Bearings may be worn	Replace bearings
	Drive shaft worn	Replace drive shaft
	Improper cutter set-up	Contact Tech Services
	Spindle contacting the work surface	Raise the cutter head
	Wheels worn out	Replace the wheels
Machine jumps erratically	RPM is too low	Turn engine throttle or speed control to highest setting
	Work surface is severely uneven	Move to smoother work surface

Problem	Cause	Solution
Drive belt wearing prematurely	Pulley is misaligned	Re-align pulley
	Wrong belt	Order new belt
Machine will not move in forward or reverse	Hydraulic fluid level may be low	Ensure hydraulic fluid level reservoir is filled to the proper level
	V-belt to hydraulic pump is slipping or damaged	Check V-belt, replace if damaged
	Lifting carriage too low / drive wheels not on work surface	Check lifting carriage is in upright position and drive wheels are in contact with work surface
DCS Control not turning on	Blown fuse on DCS Power wire.	Replace fuse on DCS Power wire.
	Power Switch is OFF or damaged.	Turn Power Switch ON. Replace Power Switch if danged.
	Battery is dead.	Charge Battery.
	DCS Control Board is damaged.	Replace DCS Control Board.
DCS Control runs for short time, then turns off	Engine is not charging the battery. Battery voltage is 14.0-15.0 VDC when engine is full throttle and charging correctly.	Check engine charging coil, voltage rectifier/regulator and fuse inside engine ignition box. Replace or repair if needed.
DCS Control is on, but actuator and/or drum housing does not move	Actuator is disconnected from DCS Control.	Check all connections.
	A DCS Control Switch is pressed or defective.	Ensure all switches are not stuck. Replace switches if defective.
	Actuator rod is stuck.	Manually move the actuator rod using the Manual Height Adjustment feature. Remove screw plug on top of the actuator, then use 6mm hex key to move the rod.
	Actuator or DCS Control Board is damaged.	See flow chart, page 33.
	Battery is low.	Charge battery.
DCS display does not match Cut Depth.	DCS Control needs to recalibrate its position.	Restart the DCS Control.
	Zero Position is not set to the work surface.	Reprogram the Zero Position. See DCS Instructions , page 19.
	The wrong FS351 model is selected on the DCS Control.	Select the correct model on DCS Control. See Menu Screens , page 15.
DCS Control Buttons work, but display is blank	The display is unplugged or damaged.	Check that the display ribbon cable and red/white wire are connected inside Control Box. Replace if damaged.

DCS Error Codes

To clear an error code on the DCS Control:

1. Turn DCS Power Switch to OFF.
2. Address/Fix the issue.
3. Turn DCS Power Switch to ON.

Error	Cause	Solution
E04: High Voltage (20VDC or greater, measured across battery posts)	Battery is damaged.	Replace battery.
	Engine voltage rectifier/regulator is damaged.	Replace engine voltage rectifier/regulator.
E05: High Motor Current (15 Amps or greater, measured on blue or brown actuator wire)	Actuator rod is stuck.	Manually move the actuator rod using the Manual Height Adjustment feature.
	Too high of load.	Ensure there is no binding anywhere on the unit when the actuator is moving.
E08: Low Voltage (7VDC or lower, measured across battery posts)	Battery is low/dead.	Charge battery.
	Engine is not charging the battery.	Check the engine charging coil and voltage rectifier/regulator. Replace or repair if needed.
E09: Hall Sensor Error	Actuator Signal Cable is disconnected from DCS Control or is damaged.	Check all connections. Repair or replace if needed.
	Actuator or DCS Control Board is damaged.	See flow chart, page 33.
E12: High Current (short circuit, 60 amps or greater, measured on red or black wire between battery and DCS Control)	A wire or board component has shorted.	Check all wires for shorts. If all wires are okay, the DCS Control board may be damaged and need to be replaced.
E31: Home Button Error	The Home Button is stuck or shorted.	Check to see if Home Button is stuck. If not stuck, replace the Home Button switch.
E32: Zero Button Error	The Zero Button is stuck or shorted.	Check to see if Zero Button is stuck. If not stuck, replace the Zero Button switch.
E33: Cut Depth Button Error	The Cut Depth Button Error is stuck or shorted.	Check to see if Cut Depth Button is stuck. If not stuck, replace the Cut Depth Button switch.
E34: Up Button Error	The Up Button is stuck or shorted.	Clear the error code. If the error code reappears 30 seconds after turning the Power Switch back ON, the problem is the Up Button on the DCS Control. Check to see if the Up Button is stuck. If not stuck, replace the Up Button Switch.
E35: Down Button Error	The Down Button is stuck or shorted.	Clear the error code. If the error code reappears 30 seconds after turning the Power Switch back ON, the problem is the Down Button on the DCS Control. Check to see if the Down Button is stuck. If not stuck, replace the Down Button Switch.

DCS Actuator Rod Does Not Move

Use this flow chart if the DCS Actuator Rod does not move or if the DCS displays error code E09 (Hall Sensor Error). Reference **Wiring Diagram**, page 68.

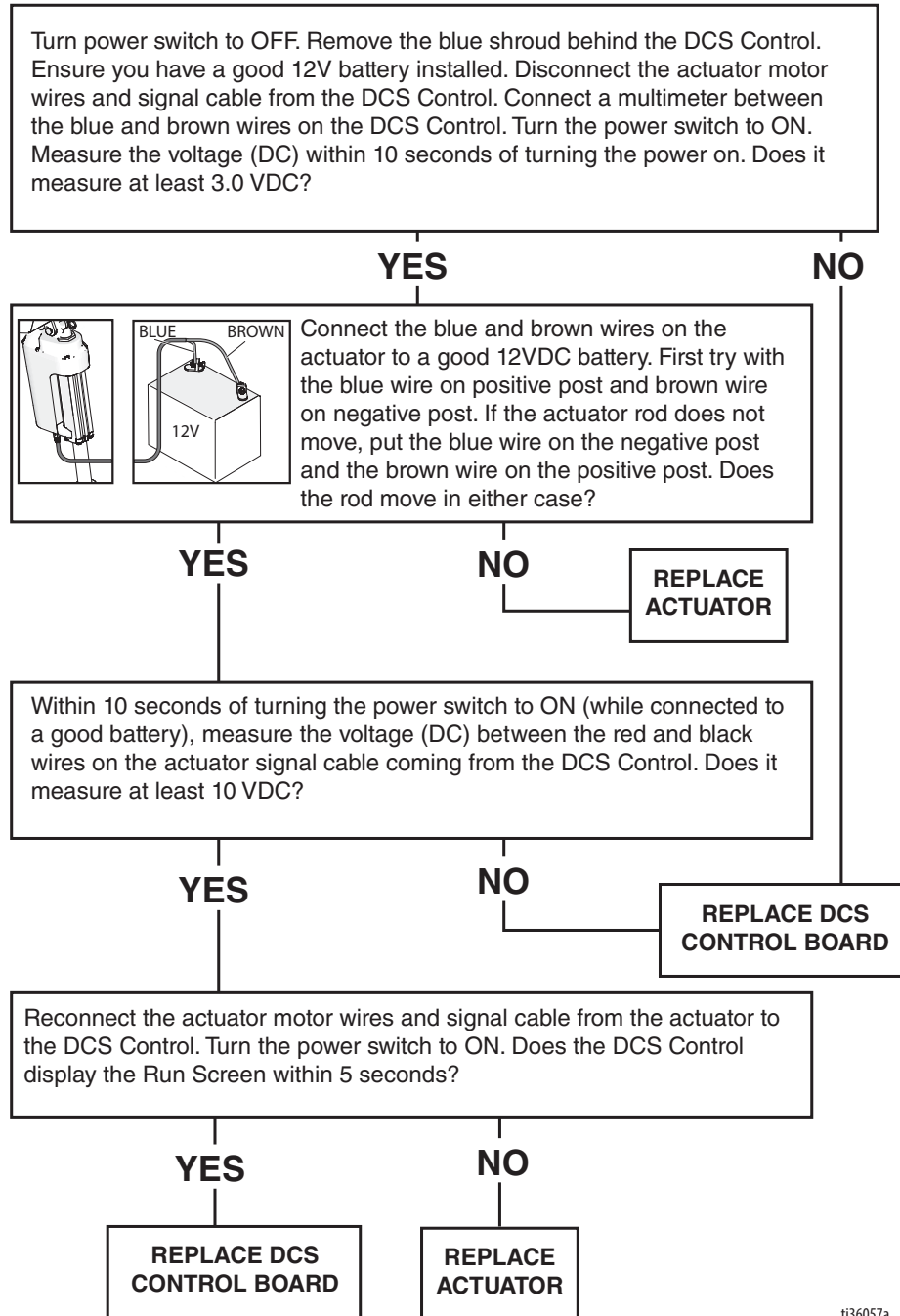

ti36057a

Parts - Main Housing Assembly (All Models)

 Torque to 23-27 ft-lbs
(31.2-36.6N·m)

 Torque to 40 ft-lbs
(54.2 N·m)

 Torque to 90-110 in-lbs
(10.2-12.4 N·m)

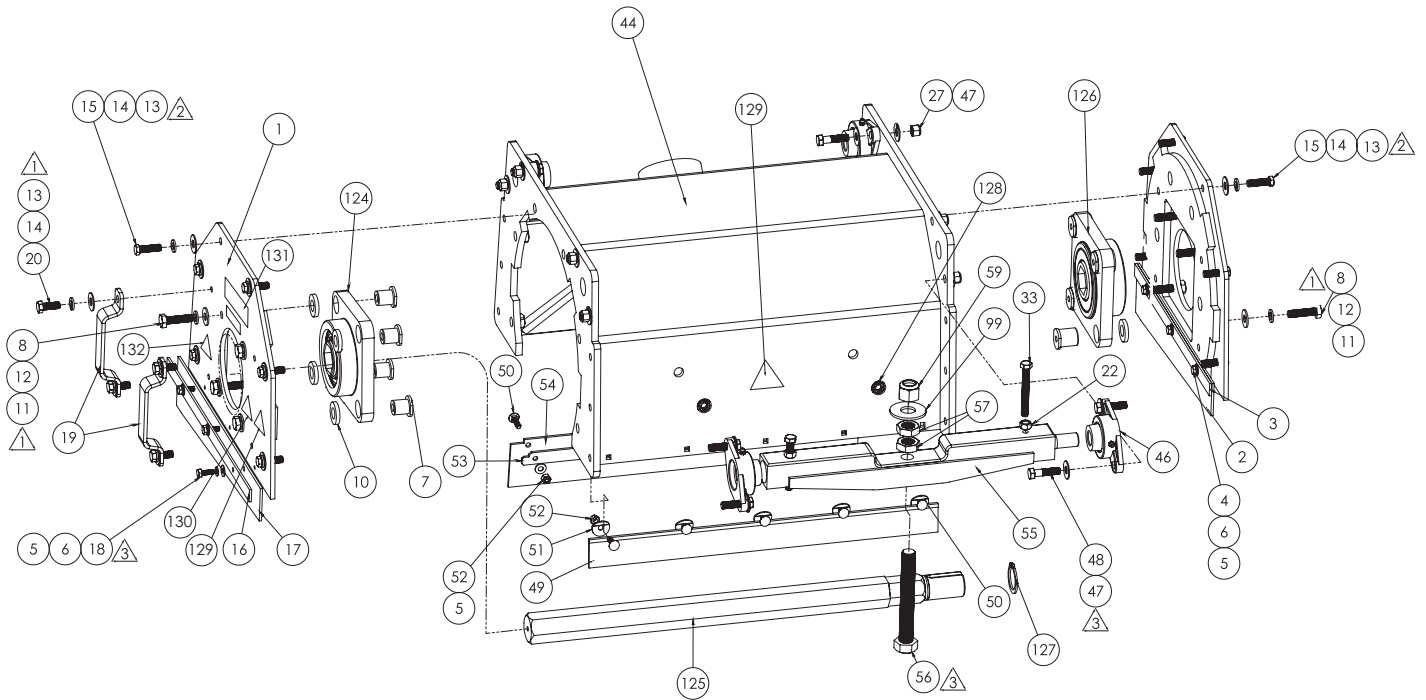

ti38091a

Parts List - Main Housing Assembly (All Models)

Ref	Part	Description	Qty	Ref	Part	Description	Qty
1	19B493	PLATE, side	2	48	HX-CS.375-16X1.5	SCREW, hex, cap, 3/8"-16 x 1.5"	8
2	18B345	SKIRT, fixed, left side	1	49	18B352	STRIPS, front, brush	1
3	18B370	PLATE, retaining, left skirt	1	50	CB.25-20X1	BOLT, carriage, 1/4"-20x1"	10
4	HX-CS.25-20X1	SCREW, hex, cap, 1/4"-20 x 1"	3	51	17W021	WASHER, fender, bend, 1/4 x 1"	5
5	FLW.25	WASHER, flat, 1/4"	11	52	NHN.25-20	NUT, nylock, 1/4"-20	14
6	SLW.25	WASHER, lock, 1/4"	6	53	18B369	PLATE, retaining, rear skirt	1
7	25U398	SLEEVE, clamping, M10-1.5	8	54	18B364	SKIRT, rear	1
8	HX-CS.M10-1.5X40mm	BOLT, hex, M10-1.5 x 40mm	8	55	18B367	PLATE, base, motor	1
10	25U399	SPACER	8	56	HX-CS.75-16X5.5	SCREW, hex, cap, 3/4"-16 x 5.5"	1
11	FLW.M10	WASHER, flat, M10	8	57	JHN.75-16	NUT, jam, 3/4"-16	2
12	SLW.M10	WASHER, lock, M10	8	59	NHN.75-16	NUT, nylock, 3/4"-16	1
13	FLW.375	WASHER, flat, 3/8"	16	99	FLW.75-2.0	WASHER, fender, 3/4"	1
14	SLW.375	WASHER, lock, 3/8"	16	124	19B365	BEARING, side, housing assy.	1
15	HX-CS.375-16x1.25	BOLT, hex, head, 3/8"-16 x 1.25"	12	125	19B374	SHAFT, hex	1
16	18B371	PLATE, retaining, right skirt	1	126	19B416	BEARING, side, housing, assy.	1
17	18B347	SKIRT, removable, right side	1	127	19B419	RING, retaining	1
18	HX-CS.25-20X.75	SCREW, hex, cap, 1/4"-20 x .75"	4	128	19B498	PLUG, inlet	1
19	18B346	HANDLES, side, plate	2	129▲	16C393	LABEL, warning, foot cut	2
20	HX-CS.375-16X1	SCREW, hex cap, 3/8"-16 x 1"	4	130▲	16D646	LABEL, warning, hot surface	1
22	HN.375-16	NUT, hex, 3/8"-16	4	131	19B331	LABEL, instructions (Gas and Propane Models)	1
27	NHN.375-16	NUT, nylock, 3/8"-16	4		19B325	LABEL, instructions (Electric Models)	1
33	HX-CS.375-16X3.FT	SCREW, hex, cap, 3/8-16 x 3"	2				
44	19B495	HOUSING, main	1	132▲	16C394	LABEL, warning, entanglement	1
46	18B465	BEARING, flange	4				
47	FLW.375G9	WASHER, flat, 3/8"	16				

▲Replacement warning, safety labels, tags, and cards are available at no cost.

Parts - Front Wheel / Wheel Carrier Assemblies (All Models)

 Torque to 40 ft-lbs
(54.2 N·m)

 Torque to 34 ft-lbs
(46.1 N·m)

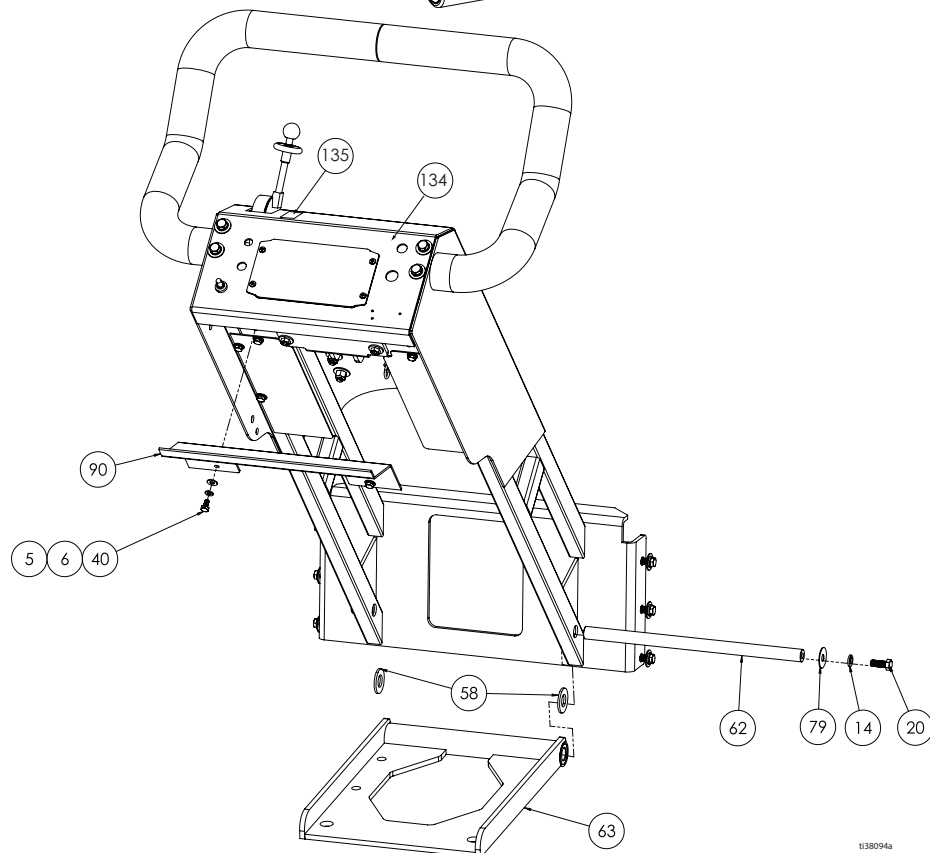
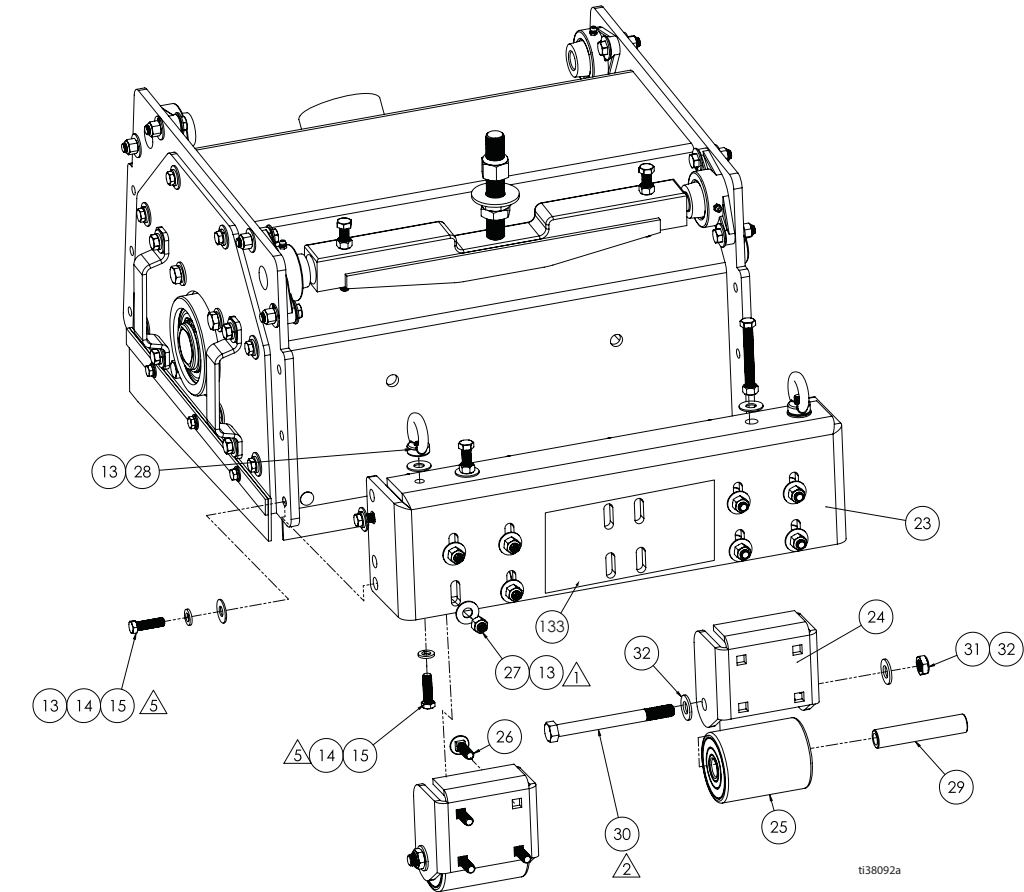

Parts List - Front Wheel / Wheel Carrier Assemblies (All Models)

Ref	Part	Description	Qty	Ref	Part	Description	Qty
5	HX-CS.25-20X1	WASHER, flat, 1/4"	1	32	FLW.50	WASHER, flat, 1/2"	2
6	SLW.25	WASHER, lock, 1/4"	1	40	HX-CS.25-20X.5	SCREW, hex, cap, 1/4"-20 x .5"	1
13	FLW.375	WASHER, flat, 3/8"	11	58	FLW.75	WASHER, flat, 3/4"	2
14	SLW.375	WASHER, lock, 3/8"	3	62	18B380	AXLE, wheel	1
15	HX-CS.375-16x1.25	BOLT, hex, 3/8"-16 x 1.25"	2	63	18B466	WHEEL, balance, assy.	1
20	HX-CS.375-16X1	SCREW, hex cap, 3/8"-16 x 1"	2	79	FNW.375-1.25	WASHER, fender, 3/8 x 1.25"	2
23	19B494	MOUNT, wheel	1	90	18B232	GUARD, rear	1
24	18B385	BRACKET, wheel	2	133	18B549	LABEL, brand, FS351 gas	1
25	18B382	ROLLER, front	2	134▲	18B548	LABEL, warning, multiple (gas and propane)	1
26	CB.375-16X1.25	BOLT, carriage, 3/8"-16 x 1.25"	8		18B554	LABEL, warning, multiple (electric)	1
27	NHN.375-16	NUT, nylock, 3/8"-16	8	135▲	19B215	LABEL, instruction, forward/reverse	1
28	18B117	NUT, eye, 3/8-16	2				
29	18B381	BUSHING, roller	2				
30	HX-CS.50-13X5.25	SCREW, hex, cap, 1/2-13 x 5.25"	2				
31	NJN.50-13	NUT, jam, nylock, 1/2-20	2				

▲Replacement warning, safety labels, tags, and cards are available at no cost.