



Express Potable Water Wagon

Operation & Parts Manual



3-16-21 21-001R0

Printed In The USA — Specifications & Design Subject To Change Without Notice!



A Message To The Owner And Operator

This equipment was carefully designed and manufactured to give you dependable service. To insure efficient operation of this equipment, please read this operator's manual carefully. Check each item and acquaint yourself with the adjustments required to maintain optimum performance and operation. ***Remember, this equipment's performance depends on how you operate and care for it!***

At the end of each use, thoroughly clean and inspect your equipment. Preventive maintenance saves time and pays dividends. Your nearest Wylie Spray Center has original equipment parts which assure proper fit and best performance. Record your equipment's model and serial numbers and the date you purchased this equipment in the space below. Have this information available when you order parts or attachments.

Model Number: _____

Serial Number: _____

Date Purchased: _____

Limited Warranty

This is a limited warranty. It covers products manufactured by WYLIE Mfg. Co. The Warrantor is **WYLIE Mfg. Co., 702 E. 40th St., Lubbock, Texas 79404 USA**. The duration of the warranty for WYLIE manufactured equipment and products (excluding polyethylene tanks) is for **one year from date of delivery to the carrier**. The Warrantor warrants to the Buyer that the product(s) sold hereunder are free from defects to material and workmanship, under normal use and service, in the hands of the original buyer.

If goods are defective, the defective goods will be replaced with identical goods. If identical goods are not available, the Buyer may elect to receive a refund of the purchase price for the defective goods, or the Buyer may order similar goods. **The damage for defective goods shall not exceed the purchase price of the defective goods. No allowance shall be made for labor or expense or repairing goods without prior approval in writing by the Warrantor.** The Buyer's remedy under this warranty does not include incidental or consequential damages.

For products not manufactured by the Warrantor, the Warrantor warrants these products to the extent of the warranties of their respective manufactures. **There are no warranties which extend beyond this limited warranty, including the implied warranty of merchantability.** Dealers or representatives shall not make any representation in regard to particular goods except as authorized by the Warrantor through a written warranty accompanying those particular goods.

Disclaimer of Warranty

WYLIE Mfg. Co., and its divisions, "Wylie Spray Centers," in each location, requires as a condition of sale and coverage by its LIMITED WARRANTY that all equipment sold by it be used in accordance with the instructions and specifications of the Warrantor. This requirement is in addition to the LIMITED WARRANTY.

Polyethylene and fiberglass tanks – These tanks are warranted for the storage and transport of water, herbicide solutions (on farm), liquid fertilizer and liquid feed. Such tanks should not be used for the storage of any bulk herbicide (undiluted). Any such use will render this warranty void.

In addition, the Warrantor makes no warranty with regard to bulkhead tank fittings used in connection with tanks containing bulk herbicides and the use of any such fittings sold by the Warrantor or any WYLIE dealer in connection with tanks containing bulk herbicides is improper.

Chemical Incompatibility – The Warrantor does not make any recommendations or warranties regarding chemical compatibility. WYLIE shall not be liable for any damages due to chemical incompatibility, and any Buyer or user should rely solely on written information furnished by the chemical manufacturer regarding chemical compatibility.

No employee of WYLIE Mfg. Co., or its representatives, agents or dealers, is authorized to vary the terms of this limited warranty.



Wylie Manufacturing Company
 702 E. 40th St.
 Lubbock, TX 79404
 Ph. 888-788-7753

Express Water Wagon or Skid

Date of Purchase		
Model Number	Type of Trailer:	
Frame Serial Number	<input type="checkbox"/> Express	<input type="checkbox"/> Arena
Tank Serial Number	<input type="checkbox"/> Fire Control	<input type="checkbox"/> Potable
Wylie Invoice Number	Trailer Capacity	
Owner's Name	<input type="checkbox"/> 500	<input type="checkbox"/> 1,025
Address	<input type="checkbox"/> 800	<input type="checkbox"/> 1,600
	Skid	
<input type="checkbox"/> 500		
City	State	Zip
Phone		
Email		
Dealer		

 Owner's Signature

Must be returned within 10 days to validate the warranty.

-- Or Register Online --
Go to: www.WylieSprayers.com



Express Potable Water Wagon

Table Of Contents

Safety Issues 2 - 3

Reporting Safety Defects..... 3

Safety Decals & Placement 4 - 5

Introduction 6

Inspection & Setup 7

Operation 8 - 9

Optional Hose Reel 10

Maintenance & Lubrication 11

Troubleshooting Guidelines 12

Tire Safety Information 13 - 23

Repair Parts..... 25 - 32

Spec Sheet..... 33



Be alert when you see the above symbol in the manual. It warns of a hazard which might lead to injury. It means: **Attention! Become alert! Your safety is Involved!**

Three (3) words (Danger, Warning, and Caution) are associated with this symbol.

DANGER – Indicates a hazardous situation, which, if not avoided, will result in death or serious injury. This signal word is to be limited to the most extreme situations.

WARNING – Indicates a hazardous situation, which, if not avoided, could result in death or serious injury.

CAUTION – Indicates a hazardous situation, which, if not avoided, may result in minor or moderate injury.

NOTICE – Indicates information considered important, but not hazard-related (e.g., messages relating to property damage).

SAFETY INSTRUCTIONS - Indicates a type of safety sign where specific safety-related instructions or procedures are described.

Before Use



Do not operate trailer until this manual has been read and understood!

- Thoroughly read and understand all instructions before operating this trailer. If you have questions, please contact **Wylie Manufacturing, 702 E. 40th St., Lubbock, TX 79404, (888) 788-7753**. You can also contact your nearest **Wylie Spray Center**.
- Make sure that the trailer is properly attached to the tow vehicle, including lights, safety chains, hitch and breakaway brake cable.
- Check lug bolts for tightness and tires for wear.
- Adjust hitch height as needed to assure that trailer is level when fully loaded.
- Always wear safety goggles, chemical resistant apron and rubber gloves when handling chemicals.
- Read and understand the chemical manufacturer's safety guidelines on handling, mixing and application.

During Use



- Do not allow anyone to ride on trailer during operation. Falling can cause injury or death.
- Reduce speed when crossing uneven or rough terrain.
- Always turn off tow vehicle engine before making adjustments or repairs to an attached trailer.
- Do not point the spray wand toward any person, animal or body part. The extreme pressure can cause severe bodily injury. (Pressure Washer model)



After Use



- Inspect trailer for wear or damage.
- Ensure that all fasteners and fittings are tight.
- Flush tank and pump with fresh water if chemicals are used. Dispose of flush water using appropriate means.
- Carry out maintenance and/or lubrication procedures as outlined in this manual.

Always



- Keep hands, feet and clothing away from moving parts and high pressure spray pattern.
- Wear protective clothing and gloves when working with chemicals.
- Assure that the hitch is attached to the proper size ball.
- Attach the safety chains and breakaway brake cable to the tow vehicle.
- Plug the lights into the tow vehicle.

Operator's Instructions



- When possible, avoid operating the tow vehicle near ditches, embankments and holes.
- Reduce speed when turning, crossing slopes and on rough, slick or muddy surfaces.
- Do not permit others to ride.
- Operate tow vehicle smoothly – no jerky turns, starts and stops.
- Hitch only to the hitch points recommended by the tow vehicle manufacturer.
- When tow vehicle is idle, engage brakes and park lock securely.
- Tighten lug bolts before transporting the first time and maintain proper torque.
- Check lights and wiring daily. Service and replace to maintain proper operation.

Wylie Manufacturing, 702 E. 40th St., Lubbock, TX 79404

Reporting Safety Defects

If you believe that your vehicle has a defect which could cause a crash or could cause injury or death, you should immediately inform the National Highway Traffic Safety Administration (NHTSA) in addition to notifying Wylie Manufacturing.

If NHTSA receives similar complaints, it may open an investigation, and if it finds that a safety defect exists in a group of vehicles, it may order a recall and remedy campaign. However, NHTSA cannot become involved in individual problems between you, your dealer, or Wylie Manufacturing.

To contact NHTSA you may either call the Auto Safety Hotline toll-free at 1-888-327-4236 (TTY: 1-800-424-9153); go to <http://www.safercar.gov>; or write to:

**NHTSA
U. S. Department of Transportation
12000 New Jersey SE
Washington, DC 20590**

You can also obtain other information about motor vehicle safety from the <http://www.safercar.gov>.



Safety Decals & Placement EXP-500L-SPW-NSF

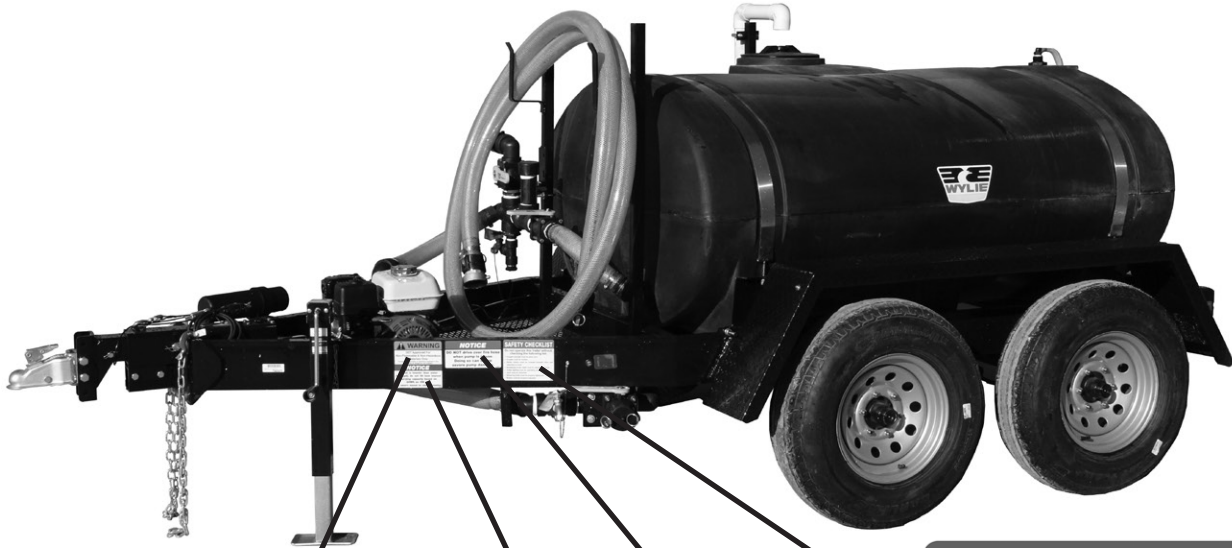

SAFETY CHECKLIST

Do not operate this trailer without checking the following list.

- ✓ Coupler and ball must be same size.
- ✓ Coupler must be locked.
- ✓ Safety chains must be crossed beneath hitch and attached to truck.
- ✓ Breakaway brake cable must be attached to truck.
- ✓ Trailer lighting must be operating properly.
- ✓ Jack must be retracted.
- ✓ Wheel lug bolts must be properly tightened.
- ✓ Brakes must be properly adjusted.

V9029

Decal #V9029

WARNING

DOT Approved For
Non-Flammable & Non-Hazardous
Materials Only

Transporting flammable or hazardous materials in this trailer may be dangerous and unlawful.

Decal #V9020

NOTICE

If fluid is heavier than water
(8 lb/gal), do not fill tank beyond
carrying capacity based on
GVWR on VIN tag.

See owner's manual for more information.
V9056

Decal #V9056

NOTICE

DO NOT drive over fire hose
when pump is in use.
Doing so can cause
severe pump damage.

V9070

Decal #V9070

Contact us at mail@wyliesprayers.com or 888-788-7753 to order safety decal or manual replacements.



Safety Decals & Placement EXP-500L-SPW-G3

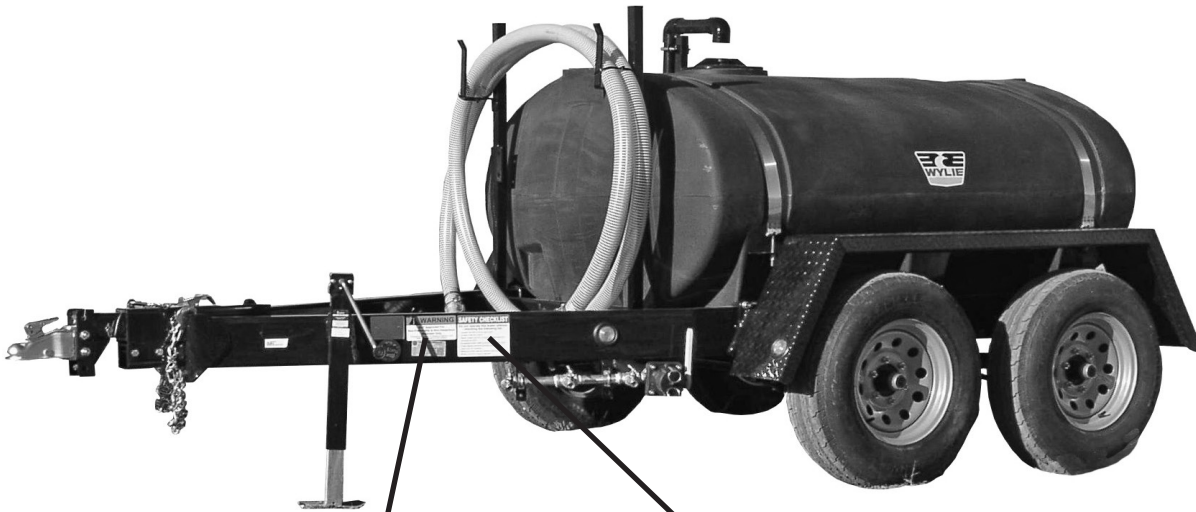

 **WARNING**

**DOT Approved For
Non-Flammable & Non-Hazardous
Materials Only**

Transporting flammable or hazardous materials in this trailer may be dangerous and unlawful.

Decal #V9020

SAFETY CHECKLIST

Do not operate this trailer without checking the following list.

- ✓ Coupler and ball must be same size.
- ✓ Coupler must be locked.
- ✓ Safety chains must be crossed beneath hitch and attached to truck.
- ✓ Breakaway brake cable must be attached to truck.
- ✓ Trailer lighting must be operating properly.
- ✓ Jack must be retracted.
- ✓ Wheel lug bolts must be properly tightened.
- ✓ Brakes must be properly adjusted.

V9029

Decal #V9029

Contact us at mail@wyliesprayers.com or 888-788-7753 to order safety decal or manual replacements.



500 Gallon Express Potable Water Wagon

Introduction

The Wylie Express Water Wagon is the result of years of testing and field proven experience. They are built of the finest materials and expert workmanship to provide you with years of reliable service.

The EXP-500L-SPW-NSF is a DOT approved trailer with a 500, 800, 1,025, or 1,600 gal. tank. All components are compatible with potable drinking water, including an NSF/ANSI 61 & 372 certified stainless steel transfer pump powered by a Honda engine, pressured 2" discharge, as well as 1 pressured and 1 gravity flow garden hose spigot, as well as 2" anti-siphon fill with food grade 20' hose.

This trailer also offers an optional hose reel with 50' of 1" hose, as well as a rear spray bar with 2 spray nozzles.

The EXP-500L-SPW-G3 is a DOT approved trailer with a 500, 800, 1,025, or 1,600 gal. tank. All components are compatible with potable drinking water, including 3 gravity flow garden hose spigots and a 2" gravity flow discharge, as well as 2" anti-siphon fill with food grade 20' hose.

The Express Potable Water Wagon has many uses, but is designed for transportation and distribution of clean, potable drinking water. This manual explains where and how to make necessary adjustments to your trailer for safe and proper operation. Thoroughly read and understand the contents of this manual before operating your sprayer. If you have questions or do not understand particular items, contact your nearest Wylie Spray Center or call Wylie Manufacturing at (888) 788-7753. Please keep this manual handy to answer questions you may have as they arise.

Pay Particular Attention To All Safety Suggestions – Their purpose is to assure safe operation of the trailer and prevent injury or damage to yourself or the unit.



Inspection & Setup

Your Express Potable Water Wagon is delivered ready for operation. However, it is suggested that you check fasteners for tightness such as lug nuts. Check the motor to assure that it has the proper oil level (see the motor operator's manual for details). Make a visual inspection to assure that nothing was damaged in shipping. Report any problems to your dealer or to Wylie Mfg.

The Express Water Wagon is equipped with a height adjustable hitch. Remove the bolts and move the hitch so that the trailer will travel level when the tank is full.

The bolted hitch can be removed to help prevent theft of the trailer.

Hitching To Pickup Truck

⚠ WARNING ⚠

Check to make sure that the ball and hitch are the same size. Attaching a 2 5/16" hitch to a 2" ball could allow the trailer to become unhitched during transport resulting in serious bodily injury.

The 500 gallon trailer is equipped with a 2" hitch while the 800, 1,025, and 1,600 gallon trailers are equipped with a 2 5/16" hitch. Make sure that the pickup or tractor has the proper ball. Engage the locking trigger and rotate the hitch lock to open the hitch. Lower the hitch on the ball. Close the hitch by rotating the hitch lock until it locks in place.

Attach the safety chains and plug in the lights. **DOT regulations require that the safety chains cross as they are attached.** Surge and electric brake trailers have an emergency brake cable that activates the trailer brakes if the trailer becomes unhitched from the pickup while travelling. Hook the brake cable to the safety chain eyelet.

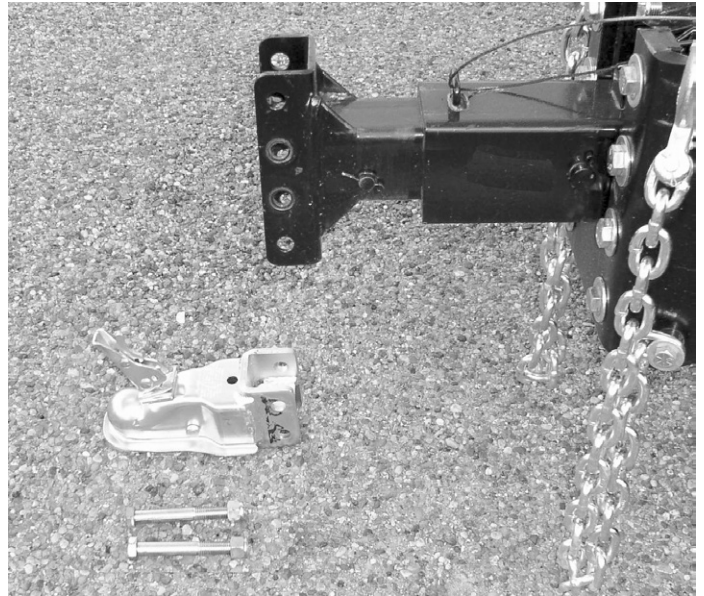

Figure A2

Remove Hitch To Prevent Theft

Pintle Hitch

Your Express Water Wagon may be equipped with a 3" ID pintle ring hitch. Lower the pintle ring on to the pintle hitch. Close and latch the pintle hitch.



Figure A1

Hitching Express Water Wagon To Pickup

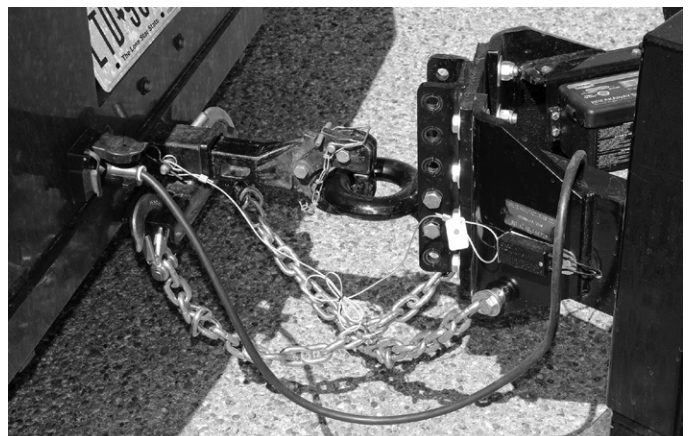

Figure A3

Hitching Express Water Wagon With Pintle



Operation - EXP-500L-SPW-NSF

This Express Potable Water Wagon features a suction and discharge manifold. The suction manifold contains the valves and fittings for filling the tank, supplying the pump and a gravity feed faucet. The discharge manifold has valves controlling the bypass, fire hose, pressure hose and spray bar.

Note: Open the ball valves by turning the handle parallel to the flow. Close the valve by turning the handle perpendicular to the flow.



Figure B1
Water Wagon Plumbing

Filling The Tank

The water tank on the Express Water Wagon can be filled by three means: (1) through the anti-siphon fill tube (2) drawing water through the pump (3) through the quick-fill fitting.

To fill the tank through the anti-siphon fill, remove the tank lid, couple the fill hose to the anti-siphon coupler and turn the water source on as shown in Figure B2. A fire hydrant adapter is provided that couples to the end of the fill hose.

If the tank is to be filled through the quick-fill fitting, couple the hose to the quick-fill coupler, and open both tank valves, then open the water source.

In order to fill the tank with the transfer pump as shown in Figure B3, close the main tank valve and attach the fill hose to the suction manifold quick-fill coupler. Open the bypass valve on the discharge manifold. Set the end of the fill hose in the pond, tank or other water source with the suction screen coupled to the end of the hose. Be sure that the suction hose

bibb is closed. A partially open hose bibb will let air into the suction manifold, causing cavitation in the pump and not build pressure.

Start the engine to pump water from the water source to the tank. If this is the first time to use the pump, it may be necessary to pour water in the top of the pump to prime it. Once the pump has water in it, it is self-priming thereafter.



Figure B2
Filling Tank Through Anti-Siphon Fill



Figure B3
Filling Trailer From Tank



The Express Potable Water Wagon features a suction and discharge manifold. The suction manifold contains the valves and fittings for filling the tank, supplying the pump and a gravity feed faucet. The discharge manifold has valves controlling the pressurized hoses, as well as any optional accessories.



Figure B4
Water Wagon Plumbing

Use of Gravity Flow Spigot

The garden hose spigot that is located on the suction manifold is useful for gravity feeding water for low volume applications. With the engine turned off, attach a garden hose to the gravity spigot. Open the main tank valve and the gravity spigot. The outlet of the hose must be lower than the level of the water in the tank for the water to gravity flow through the hose.

This option allows for many applications, without the need for high water pressure, including, but not limited to: oilfield, agriculture, remote personal property, municipal, military and commercial.



Figure B5
Use of Pressurized Hose

Use of Pressurized Hoses

The EXP-500L-SPW-NSF can be equipped with a rubber hose and nozzle for pressurized applications. Attach the rubber hose to the pressure bibb and open the main tank valve. Start the engine and run a full throttle, and open the pressure bibb.

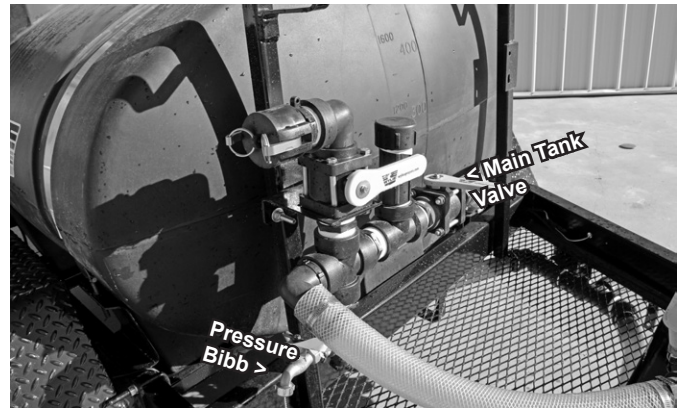

Figure B6
Water Wagon Plumbing

Stainless Steel Pump

The option for pressurized water is a feature that separates the EXP-500L-SPW-NSF from the competition. Pacer Pumps, a Division of ASM Industries, has earned certification to NSF/ANSI 61 & 372, the American National Standard for Drinking Water System Components. This certification comes from the global public health organization NSF International. The IPW Series pump on this Express Potable Water Wagon is a self-priming centrifugal pump with a vertical suction lift of 20 feet and a maximum flow rate of 180 gallons per minute. It is ideal for transferring and delivery of bulk potable (drinking) water. Pump construction features stainless steel casing, FDA grade polypropylene internal components and FDA grade elastomers. The operation and parts manual for the Pacer Pump and Honda Engine are included separately in the manual canister.

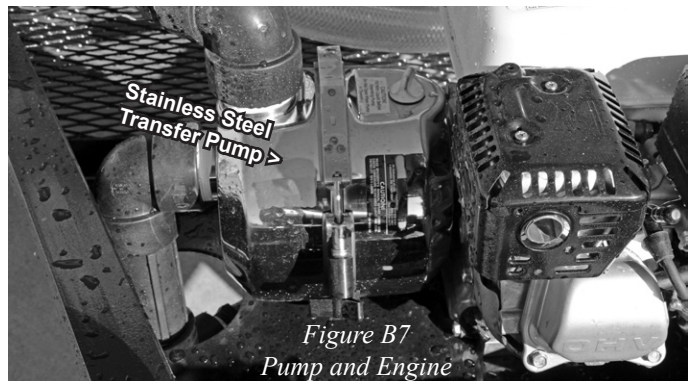

Figure B7
Pump and Engine



Optional Hose Reel

Optional Hose Reel

The Express Water Wagon can be fitted at the factory or as an aftermarket option with a hose reel for a 50', 1" hose and fire nozzle.

Aftermarket Set-up

Loosely attach the crossmember to the frame just below the hose hangers. Set the A-frame on the trailer frame and under the swivel frame. Attach the A-frame with U-bolts. Mark holes through the A-frame mount brackets. Drill 1/2" holes through the trailer frame. Secure the A-frame mount brackets with the 1/2"x1" bolts. Tighten all mounting bolts.

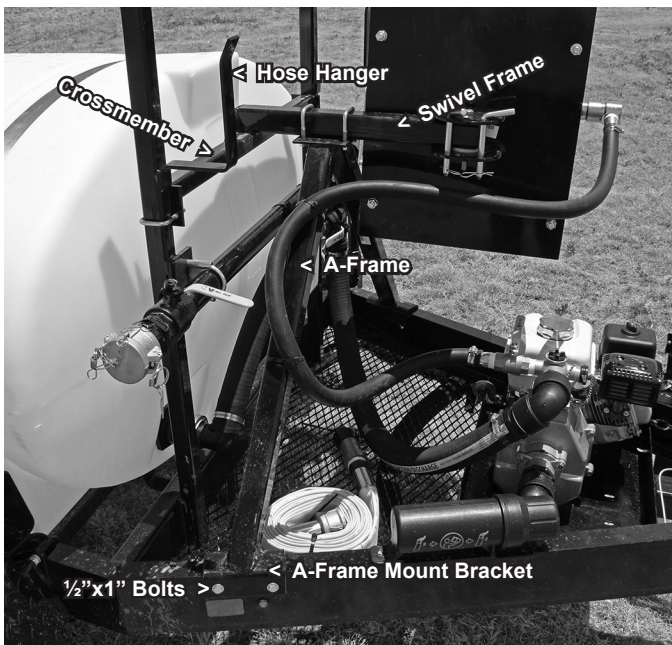

Figure C1

Hose Reel Frame Mounting

Set the hose reel mounting plate in the swivel bracket with a nylon washer above and below the swivel frame. Secure with the 1/2"x4 1/2" bolt.

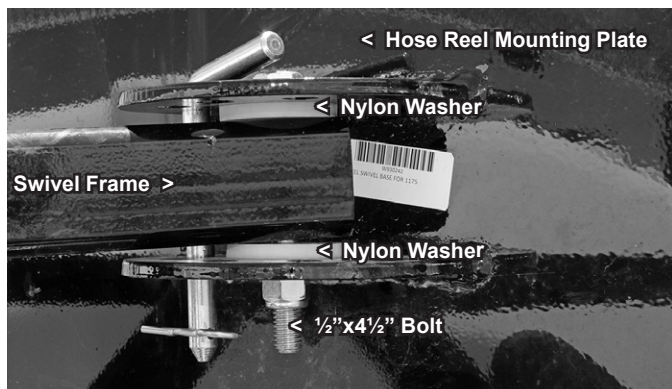

Figure C2

Hose Reel Mounting Plate

Bolt the hose reel to the mounting plate with 1/2"x1" bolts. Insert the bent pull pins in the swivel bracket.



Figure C3

Hose Reel Attached to Mounting Plate

Bolt the handle to the reel arm. Apply thread sealant to the hose threads and screw into the hose reel fitting. Roll the hose onto the hose reel. Attach the fire nozzle. Lock the hose reel in position with the spring loaded lock pin.

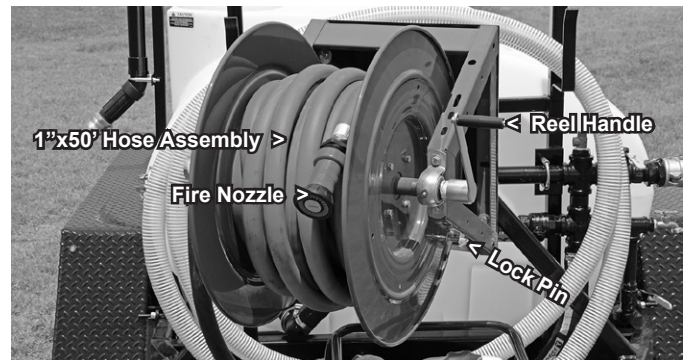

Figure C4

Rolling Hose on Hose Reel

Hose Reel Operation

Remove the bent pull pins and swivel the hose reel to the desired direction. Rotate the reel lock pin to the unlock position. Unroll the hose to the desired length. Open the Main Valve, then open the Hose Reel Valve. Start the engine and rotate the fire hose nozzle to open the nozzle to the desired pattern; from wide fan to straight stream.



Maintenance

The Express Water Wagon is a low maintenance machine, but will operate much longer if due care is taken on a regular basis. Several times each season it should be examined for worn hoses, loose fasteners, worn tires, and leaks. Refer to the engine and pump owner’s manual for information regarding maintenance on these components.

From time to time it may be necessary to drain the main tank such as during cold weather. Remove the quick-fill cap, open the main tank valve, then open the quick fill valve to drain the tank. Follow instructions for draining the pump, located in pump manual.

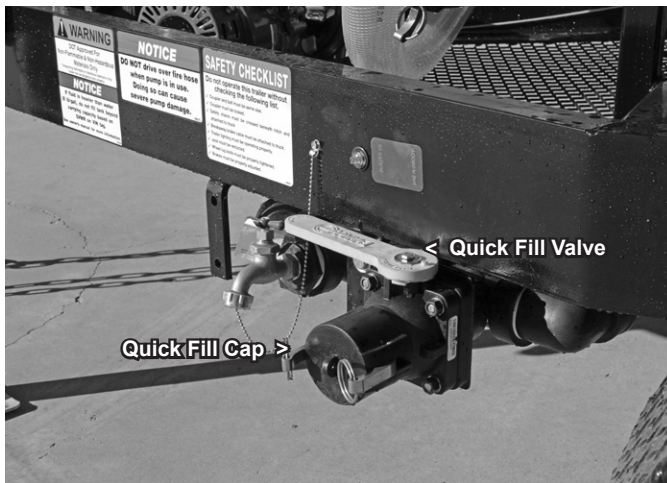

Figure D1
Main Tank Drain

This trailer’s parts and components are made of food grade materials, and are not intended for anything other than potable water. Adding chemicals to the tank and/or plumbing system will not only void the warranty, but could cause damage to the system. In addition, contaminating the tank and plumbing with harmful chemicals could result in serious injury or death.

⚠ WARNING ⚠

This trailer is designed for potable water only. Consumption of harmful chemicals could result in serious injury or death.

Lubrication

Check the engine owner’s manual for the proper oil to add to the engine.

Some models are equipped with Accu-Lube hubs. If your trailer is equipped with the Accu-Lube system remove the rubber plug and place grease gun (no air powered grease guns) onto the zerk. Pump in new grease until you see the old grease flowing back out of the cap. Wipe off old grease with a towel. Be sure to re-install rubber plug. Service every 12 months or 12,000 miles. Service more often in extremely dusty and/or wet conditions.

Standard hubs should be packed once a year or more often in severe conditions.



Figure D2
Wheel With Accu-Lube Hub



Troubleshooting Guidelines

Problem	Cause	Solution
Pump Will Not Operate	(1) Engine not starting or running properly	(1) Refer to engine owner's manual
Pump will not spray solution	(1) Spray tank empty (2) Main tank ball valve closed (3) Malfunctioning pump (4) Proper discharge valve not open	(1) Fill tank (2) Open ball valve (3) See pump owners manual or contact Wylie Spray Center (4) See operation section of manual
Pump output is very low; erratic	(1) Spray tank low; air getting in pump (2) Tank ball valve partially closed (3) Collapsed suction hose (4) Air leak in suction system (5) Malfunctioning pump (6) Engine speed too slow	(1) Fill tank (2) Open ball valve (3) Replace suction hose (4) Tighten fittings; Check for cracked or cut components; Apply thread sealant to pipe threads; Close suction manifold bibb. (5) See pump owners manual or contact Wylie Spray Center (6) Increase engine speed
Gun or nozzles do not operate	(1) Controlling ball valve not open	(1) Open appropriate ball valve
No output or insufficient pressure at spray tip(s)	(1) Air leak in suction side of system (2) Problem with pump (3) Ball valve malfunctioning (4) Bypass valve open	(1) See above (2) See above (3) Repair or replace ball valve (4) Close bypass valve
Spray pattern uneven at one tip	(1) Trash in tip orifice (2) Damaged tip orifice (3) Worn or damaged tip	(1) Clean tip (2), (3) Replace tip



Tire Safety Information

1. TIRE SAFETY INFORMATION

This portion of the User's Manual contains tire safety information as required by 49 CFR 575.6.

Section 2.1 contains "Steps for Determining Correct Load Limit - Trailer".

Section 2.2 contains "Steps for Determining Correct Load Limit – Tow Vehicle".

Section 2.3 contains a Glossary of Tire Terminology, including "cold inflation pressure", "maximum inflation pressure", "recommended inflation pressure", and other non-technical terms.

Section 2.4 contains information from the NHTSA brochure entitled "Tire Safety – Everything Rides On It". This brochure, as well as the preceding subsections, describes the following items;

- Tire labeling, including a description and explanation of each marking on the tires, and information about the DOT Tire Identification Number (TIN).
- Recommended tire inflation pressure, including a description and explanation of:
 - A. Cold inflation pressure.
 - B. Vehicle Placard and location on the vehicle.
 - C. Adverse safety consequences of under inflation (including tire failure).
 - D. Measuring and adjusting air pressure for proper inflation.
- Tire Care, including maintenance and safety practices.
- Vehicle load limits, including a description and explanation of the following items:
 - A. Locating and understanding the load limit information, total load capacity, and cargo capacity.
 - B. Calculating total and cargo capacities with varying seating configurations including quantitative examples showing / illustrating how the vehicles cargo and luggage capacity decreases as combined number and size of occupants' increases. This item is also discussed in Section 3.
 - C. Determining compatibility of tire and vehicle load capabilities.
 - D. Adverse safety consequences of overloading on handling and stopping on tires.

1.1. STEPS FOR DETERMINING CORRECT LOAD LIMIT – TRAILER

Determining the load limits of a trailer includes more than understanding the load limits of the tires alone. On all trailers there is a Federal certification/VIN label that is located on the forward half of the left (road) side of the unit. This certification/VIN label will indicate the trailer's Gross Vehicle Weight Rating (GVWR). This is the most weight the fully loaded trailer can weigh. It will also provide the Gross Axle Weight Rating (GAWR). This is the most a particular axle can weigh. If there are multiple axles, the GAWR of each axle will be provided.

If your trailer has a GVWR of 10,000 pounds or less, there is a vehicle placard located in the same location as the certification label described above. This placard provides tire and loading information. In addition, this placard will show a statement regarding maximum cargo capacity. Cargo can be added to the trailer, up to the maximum weight specified on the placard. The combined weight of the cargo is provided as a single number. In any case, remember: the total weight of a fully loaded trailer can not exceed the stated GVWR.

For trailers with living quarters installed, the weight of water and propane also need to be considered. The weight of fully filled propane containers is considered part of the weight of the trailer before it is loaded with cargo, and is not considered part of the disposable cargo load. Water however, is a disposable cargo weight and is treated as such. If there is a fresh water storage tank of 100 gallons, this tank when filled would weigh about 800 pounds. If more cargo is being transported, water can be off-loaded to keep the total amount of cargo added to the vehicle within the limits of the GVWR so as not to overload the vehicle. Understanding this flexibility will allow you, the owner, to make choices that fit your travel needs.

When loading your cargo, be sure it is distributed evenly to prevent overloading front to back and side to side. Heavy items should be placed low and as close to the axle positions as reasonable. Too many items on one side may overload a tire. The best way to know the actual weight of the vehicle is to weigh it at a public scale. Talk to your dealer to discuss the weighing methods needed to capture the various weights related to the trailer. This would include the weight empty or unloaded, weights per axle, wheel, hitch or king-pin, and total weight.



Tire Safety Information

Excessive loads and/or underinflation cause tire overloading and, as a result, abnormal tire flexing occurs. This situation can generate an excessive amount of heat within the tire. Excessive heat may lead to tire failure. It is the air pressure that enables a tire to support the load, so proper inflation is critical. The proper air pressure may be found on the certification/VIN label and/or on the Tire Placard. This value should never exceed the maximum cold inflation pressure stamped on the tire.

1.1.1. TRAILERS 10,000 POUNDS GVWR OR LESS

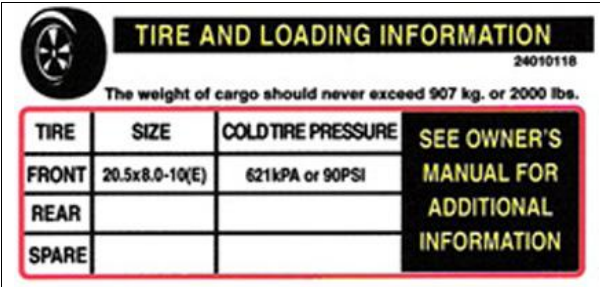

The weight of cargo should never exceed 907 kg. or 2000 lbs.

TIRE	SIZE	COLD TIRE PRESSURE	SEE OWNER'S MANUAL FOR ADDITIONAL INFORMATION
FRONT	20.5x8.0-10(E)	621kPA or 90PSI	
REAR			
SPARE			

Tire and Loading Information Placard – Figure 1-1

1. Locate the statement, “The weight of cargo should never exceed XXX kg or XXX lbs.,” on your vehicle’s placard. See figure 1-1.
2. This figure equals the available amount of cargo and luggage load capacity.
3. Determine the combined weight of luggage and cargo being loaded on the vehicle. That weight may not safely exceed the available cargo and luggage load capacity.

The trailer’s placard refers to the Tire Information Placard attached adjacent to or near the trailer’s VIN (Certification) label at the left front of the trailer.

1.1.2. TRAILERS OVER 10,000 POUNDS GVWR (NOTE: THESE TRAILERS ARE NOT REQUIRED TO HAVE A TIRE INFORMATION PLACARD ON THE VEHICLE)

1. Determine the empty weight of your trailer by weighing the trailer using a public scale or other means. This step does not have to be repeated.
2. Locate the GVWR (Gross Vehicle Weight Rating) of the trailer on your trailer’s VIN (Certification) label.
3. Subtract the empty weight of your trailer from the GVWR stated on the VIN label. That weight is the maximum available cargo capacity of the trailer and may not be safely exceeded.

1.2. STEPS FOR DETERMINING CORRECT LOAD LIMIT – TOW VEHICLE

1. Locate the statement, “The combined weight of occupants and cargo should never exceed XXX lbs.,” on your vehicle’s placard.
2. Determine the combined weight of the driver and passengers who will be riding in your vehicle.
3. Subtract the combined weight of the driver and passengers from XXX kilograms or XXX pounds.
4. The resulting figure equals the available amount of cargo and luggage capacity. For example, if the “XXX” amount equals 1400 lbs. and there will be five 150 lb. passengers in your vehicle, the amount of available cargo and luggage capacity is 650 lbs. (1400-750 (5 x 150) = 650 lbs.).
5. Determine the combined weight of luggage and cargo being loaded on the vehicle. That weight may not safely exceed the available cargo and luggage capacity calculated in Step # 4.
6. If your vehicle will be towing a trailer, load from your trailer will be transferred to your vehicle. Consult the tow vehicle’s manual to determine how this weight transfer reduces the available cargo and luggage capacity of your vehicle.

1.3. GLOSSARY OF TIRE TERMINOLOGY

Accessory weight

The combined weight (in excess of those standard items which may be replaced) of automatic transmission, power steering, power brakes, power windows, power seats, radio and heater, to the extent that these items are available as factory-installed equipment (whether installed or not).



Bead

The part of the tire that is made of steel wires, wrapped or reinforced by ply cords and that is shaped to fit the rim.

Bead separation

This is the breakdown of the bond between components in the bead.

Bias ply tire

A pneumatic tire in which the ply cords that extend to the beads are laid at alternate angles substantially less than 90 degrees to the centerline of the tread.

Carcass

The tire structure, except tread and sidewall rubber which, when inflated, bears the load.

Chunking

The breaking away of pieces of the tread or sidewall.

Cold inflation pressure

The pressure in the tire before you drive.

Cord

The strands forming the plies in the tire.

Cord separation

The parting of cords from adjacent rubber compounds.

Cracking

Any parting within the tread, sidewall, or inner liner of the tire extending to cord material.

CT

A pneumatic tire with an inverted flange tire and rim system in which the rim is designed with rim flanges pointed radially inward and the tire is designed to fit on the underside of the rim in a manner that encloses the rim flanges inside the air cavity of the tire.

Curb weight

The weight of a motor vehicle with standard equipment including the maximum capacity of fuel, oil, and coolant, and, if so equipped, air conditioning and additional weight optional engine.

Extra load tire

A tire designed to operate at higher loads and at higher inflation pressures than the corresponding standard tire.

Groove

The space between two adjacent tread ribs.

Gross Axle Weight Rating

The maximum weight that any axle can support, as published on the Certification / VIN label on the front left side of the trailer. Actual weight determined by weighing each axle on a public scale, with the trailer attached to the towing vehicle.

Gross Vehicle Weight Rating

The maximum weight of the fully loaded trailer, as published on the Certification / VIN label. Actual weight determined by weighing trailer on a public scale, without being attached to the towing vehicle.

Hitch Weight

The downward force exerted on the hitch ball by the trailer coupler.

Innerliner

The layer(s) forming the inside surface of a tubeless tire that contains the inflating medium within the tire.

Innerliner separation

The parting of the innerliner from cord material in the carcass.

**Intended outboard sidewall**

The sidewall that contains a white-wall, bears white lettering or bears manufacturer, brand, and/or model name molding that is higher or deeper than the same molding on the other sidewall of the tire or the outward facing sidewall of an asymmetrical tire that has a particular side that must always face outward when mounted on a vehicle.

Light truck (LT) tire

A tire designated by its manufacturer as primarily intended for use on lightweight trucks or multipurpose passenger vehicles.

Load rating

The maximum load that a tire is rated to carry for a given inflation pressure.

Maximum load rating

The load rating for a tire at the maximum permissible inflation pressure for that tire.

Maximum permissible inflation pressure

The maximum cold inflation pressure to which a tire may be inflated.

Maximum loaded vehicle weight

The sum of curb weight, accessory weight, vehicle capacity weight, and production options weight.

Measuring rim

The rim on which a tire is fitted for physical dimension requirements.

Pin Weight

The downward force applied to the 5th wheel or gooseneck ball, by the trailer kingpin or gooseneck coupler.

Non-pneumatic rim

A mechanical device which, when a non-pneumatic tire assembly incorporates a wheel, supports the tire, and attaches, either integrally or separably, to the wheel center member and upon which the tire is attached.

Non-pneumatic spare tire assembly

A non-pneumatic tire assembly intended for temporary use in place of one of the pneumatic tires and rims that are fitted to a passenger car in compliance with the requirements of this standard.

Non-pneumatic tire

A mechanical device which transmits, either directly or through a wheel or wheel center member, the vertical load and tractive forces from the roadway to the vehicle, generates the tractive forces that provide the directional control of the vehicle and does not rely on the containment of any gas or fluid for providing those functions.

Non-pneumatic tire assembly

A non-pneumatic tire, alone or in combination with a wheel or wheel center member, which can be mounted on a vehicle.

Normal occupant weight

This means 68 kilograms (150 lbs.) times the number of occupants specified in the second column of Table I of 49 CFR 571.110.

Occupant distribution

The distribution of occupants in a vehicle as specified in the third column of Table I of 49 CFR 571.110.

Open splice

Any parting at any junction of tread, sidewall, or innerliner that extends to cord material.

Outer diameter

The overall diameter of an inflated new tire.

Overall width



The linear distance between the exteriors of the sidewalls of an inflated tire, including elevations due to labeling, decorations, or protective bands or ribs.

Ply

A layer of rubber-coated parallel cords.

Ply separation

A parting of rubber compound between adjacent plies.

Pneumatic tire

A mechanical device made of rubber, chemicals, fabric and steel or other materials, that, when mounted on an automotive wheel, provides the traction and contains the gas or fluid that sustains the load.

Production options weight

The combined weight of those installed regular production options weighing over 2.3 kilograms (5 lbs.) in excess of those standard items which they replace, not previously considered in curb weight or accessory weight, including heavy duty brakes, ride levelers, roof rack, heavy duty battery, and special trim.

Radial ply tire

A pneumatic tire in which the ply cords that extend to the beads are laid at substantially 90 degrees to the centerline of the tread.

Recommended inflation pressure

This is the inflation pressure provided by the vehicle manufacturer on the Tire Information label and on the Certification / VIN tag.

Reinforced tire

A tire designed to operate at higher loads and at higher inflation pressures than the corresponding standard tire.

Rim

A metal support for a tire or a tire and tube assembly upon which the tire beads are seated.

Rim diameter

This means the nominal diameter of the bead seat.

Rim size designation

This means the rim diameter and width.

Rim type designation

This means the industry of manufacturer's designation for a rim by style or code.

Rim width

This means the nominal distance between rim flanges.

Section width

The linear distance between the exteriors of the sidewalls of an inflated tire, excluding elevations due to labeling, decoration, or protective bands.

Sidewall

That portion of a tire between the tread and bead.

Sidewall separation

The parting of the rubber compound from the cord material in the sidewall.

Special Trailer (ST) tire

The "ST" is an indication the tire is for trailer use only.

Test rim

The rim on which a tire is fitted for testing, and may be any rim listed as appropriate for use with that tire.

Tread



That portion of a tire that comes into contact with the road.

Tread rib

A tread section running circumferentially around a tire.

Tread separation

Pulling away of the tread from the tire carcass.

Treadwear indicators (TWI)

The projections within the principal grooves designed to give a visual indication of the degrees of wear of the tread.

Vehicle capacity weight

The rated cargo and luggage load plus 68 kilograms (150 lbs.) times the vehicle's designated seating capacity.

Vehicle maximum load on the tire

The load on an individual tire that is determined by distributing to each axle its share of the maximum loaded vehicle weight and dividing by two.

Vehicle normal load on the tire

The load on an individual tire that is determined by distributing to each axle its share of the curb weight, accessory weight, and normal occupant weight (distributed in accordance with Table I of CRF 49 571.110) and dividing by 2.

Weather side

The surface area of the rim not covered by the inflated tire.

Wheel center member

In the case of a non-pneumatic tire assembly incorporating a wheel, a mechanical device which attaches, either integrally or separably, to the non-pneumatic rim and provides the connection between the non-pneumatic rim and the vehicle; or, in the case of a non-pneumatic tire assembly not incorporating a wheel, a mechanical device which attaches, either integrally or separably, to the non-pneumatic tire and provides the connection between tire and the vehicle.

Wheel-holding fixture

The fixture used to hold the wheel and tire assembly securely during testing.

1.4. TIRE SAFETY - EVERYTHING RIDES ON IT

The National Traffic Safety Administration (NHTSA) has published a brochure (DOT HS 809 361) that discusses all aspects of Tire Safety, as required by CFR 575.6. This brochure is reproduced in part below. It can be obtained and downloaded from NHTSA, free of charge, from the following web site:

http://www.nhtsa.dot.gov/cars/rules/TireSafety/ridesonit/tires_index.html

Studies of tire safety show that maintaining proper tire pressure, observing tire and vehicle load limits (not carrying more weight in your vehicle than your tires or vehicle can safely handle), avoiding road hazards, and inspecting tires for cuts, slashes, and other irregularities are the most important things you can do to avoid tire failure, such as tread separation or blowout and flat tires. These actions, along with other care and maintenance activities, can also:

- Improve vehicle handling
- Help protect you and others from avoidable breakdowns and accidents
- Improve fuel economy
- Increase the life of your tires.

This booklet presents a comprehensive overview of tire safety, including information on the following topics:

- Basic tire maintenance
- Uniform Tire Quality Grading System
- Fundamental characteristics of tires



- Tire safety tips.

Use this information to make tire safety a regular part of your vehicle maintenance routine. Recognize that the time you spend is minimal compared with the inconvenience and safety consequences of a flat tire or other tire failure.

1.5. SAFETY FIRST—BASIC TIRE MAINTENANCE

Properly maintained tires improve the steering, stopping, traction, and load-carrying capability of your vehicle. Underinflated tires and overloaded vehicles are a major cause of tire failure. Therefore, as mentioned above, to avoid flat tires and other types of tire failure, you should maintain proper tire pressure, observe tire and vehicle load limits, avoid road hazards, and regularly inspect your tires.

1.5.1. FINDING YOUR VEHICLE'S RECOMMENDED TIRE PRESSURE AND LOAD LIMITS

Tire information placards and vehicle certification labels contain information on tires and load limits. These labels indicate the vehicle manufacturer's information including:

- Recommended tire size
- Recommended tire inflation pressure
- Vehicle capacity weight (VCW—the maximum occupant and cargo weight a vehicle is designed to carry)
- Front and rear gross axle weight ratings (GAWR—the maximum weight the axle systems are designed to carry).

Both placards and certification labels are permanently attached to the trailer near the left front.

1.5.2. UNDERSTANDING TIRE PRESSURE AND LOAD LIMITS

Tire inflation pressure is the level of air in the tire that provides it with load-carrying capacity and affects the overall performance of the vehicle. The tire inflation pressure is a number that indicates the amount of air pressure—measured in pounds per square inch (psi)—a tire requires to be properly inflated. (You will also find this number on the vehicle information placard expressed in kilopascals (kpa), which is the metric measure used internationally.)

Manufacturers of passenger vehicles and light trucks determine this number based on the vehicle's design load limit, that is, the greatest amount of weight a vehicle can safely carry and the vehicle's tire size. The proper tire pressure for your vehicle is referred to as the "recommended cold inflation pressure." (As you will read below, it is difficult to obtain the recommended tire pressure if your tires are not cold.) Because tires are designed to be used on more than one type of vehicle, tire manufacturers list the "maximum permissible inflation pressure" on the tire sidewall. This number is the greatest amount of air pressure that should ever be put in the tire under normal driving conditions.

1.5.3. CHECKING TIRE PRESSURE

It is important to check your vehicle's tire pressure at least once a month for the following reasons:

- Most tires may naturally lose air over time.
- Tires can lose air suddenly if you drive over a pothole or other object or if you strike the curb when parking.
- With radial tires, it is usually not possible to determine underinflation by visual inspection.

For convenience, purchase a tire pressure gauge to keep in your vehicle. Gauges can be purchased at tire dealerships, auto supply stores, and other retail outlets.

The recommended tire inflation pressure that vehicle manufacturers provide reflects the proper psi when a tire is cold. The term cold does not relate to the outside temperature. Rather, a cold tire is one that has not been driven on for at least three hours. When you drive, your tires get warmer, causing the air pressure within them to increase. Therefore, to get an accurate tire pressure reading, you must measure tire pressure when the tires are cold or compensate for the extra pressure in warm tires.



Tire Safety Information

1.5.4. STEPS FOR MAINTAINING PROPER TIRE PRESSURE

- Step 1: Locate the recommended tire pressure on the vehicle's tire information placard, certification label, or in the owner's manual.
- Step 2: Record the tire pressure of all tires.
- Step 3: If the tire pressure is too high in any of the tires, slowly release air by gently pressing on the tire valve stem with the edge of your tire gauge until you get to the correct pressure.
- Step 4: If the tire pressure is too low, note the difference between the measured tire pressure and the correct tire pressure. These "missing" pounds of pressure are what you will need to add.
- Step 5: At a service station, add the missing pounds of air pressure to each tire that is underinflated.
- Step 6: Check all the tires to make sure they have the same air pressure (except in cases in which the front and rear tires are supposed to have different amounts of pressure).

If you have been driving your vehicle and think that a tire is underinflated, fill it to the recommended cold inflation pressure indicated on your vehicle's tire information placard or certification label. While your tire may still be slightly underinflated due to the extra pounds of pressure in the warm tire, it is safer to drive with air pressure that is slightly lower than the vehicle manufacturer's recommended cold inflation pressure than to drive with a significantly underinflated tire. Since this is a temporary fix, don't forget to recheck and adjust the tire's pressure when you can obtain a cold reading.

1.5.5. TIRE SIZE

To maintain tire safety, purchase new tires that are the same size as the vehicle's original tires or another size recommended by the manufacturer. Look at the tire information placard, the owner's manual, or the sidewall of the tire you are replacing to find this information. If you have any doubt about the correct size to choose, consult with the tire dealer.

1.5.6. TIRE TREAD

The tire tread provides the gripping action and traction that prevent your vehicle from slipping or sliding, especially when the road is wet or icy. In general, tires are not safe and should be replaced when the tread is worn down to 1/16 of an inch. Tires have built-in treadwear indicators that let you know when it is time to replace your tires. These indicators are raised sections spaced intermittently in the bottom of the tread grooves. When they appear "even" with the outside of the tread, it is time to replace your tires. Another method for checking tread depth is to place a penny in the tread with Lincoln's head upside down and facing you. If you can see the top of Lincoln's head, you are ready for new tires.

1.5.7. TIRE BALANCE AND WHEEL ALIGNMENT

To avoid vibration or shaking of the vehicle when a tire rotates, the tire must be properly balanced. This balance is achieved by positioning weights on the wheel to counterbalance heavy spots on the wheel-and-tire assembly. A wheel alignment adjusts the angles of the wheels so that they are positioned correctly relative to the vehicle's frame. This adjustment maximizes the life of your tires. These adjustments require special equipment and should be performed by a qualified technician.

1.5.8. TIRE REPAIR

The proper repair of a punctured tire requires a plug for the hole and a patch for the area inside the tire that surrounds the puncture hole. Punctures through the tread can be repaired if they are not too large, but punctures to the sidewall should not be repaired. Tires must be removed from the rim to be properly inspected before being plugged and patched.

1.5.9. TIRE FUNDAMENTALS

Federal law requires tire manufacturers to place standardized information on the sidewall of all tires. This information identifies and describes the fundamental characteristics of the tire and also provides a tire identification number for safety standard certification and in case of a recall.



1.5.9.1. Information on Passenger Vehicle Tires

Please refer to the diagram below.

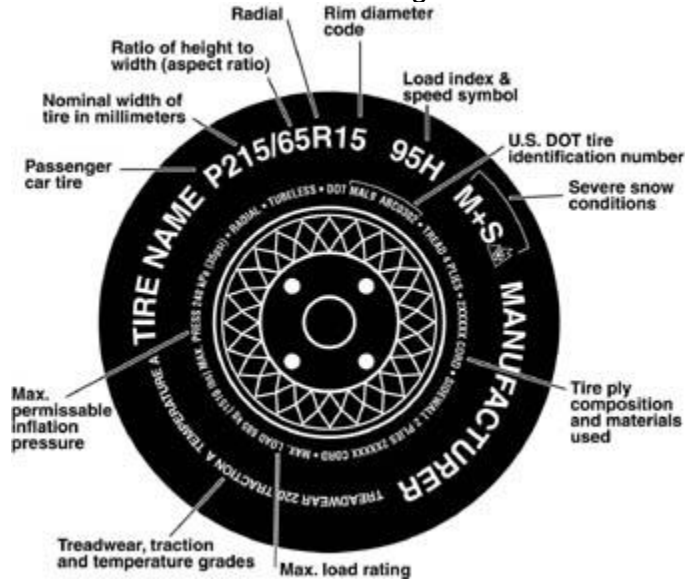

P

The "P" indicates the tire is for passenger vehicles.

Next number

This three-digit number gives the width in millimeters of the tire from sidewall edge to sidewall edge. In general, the larger the number, the wider the tire.

Next number

This two-digit number, known as the aspect ratio, gives the tire's ratio of height to width. Numbers of 70 or lower indicate a short sidewall for improved steering response and better overall handling on dry pavement.

R

The "R" stands for radial. Radial ply construction of tires has been the industry standard for the past 20 years.

Next number

This two-digit number is the wheel or rim diameter in inches. If you change your wheel size, you will have to purchase new tires to match the new wheel diameter.

Next number

This two- or three-digit number is the tire's load index. It is a measurement of how much weight each tire can support. You may find this information in your owner's manual. If not, contact a local tire dealer. Note: You may not find this information on all tires because it is not required by law.

M+S

The "M+S" or "M/S" indicates that the tire has some mud and snow capability. Most radial tires have these markings; hence, they have some mud and snow capability.

Speed Rating

The speed rating denotes the speed at which a tire is designed to be driven for extended periods of time. The ratings range from 99 miles per hour (mph) to 186 mph. These ratings are listed below. Note: You may not find this information on all tires because it is not required by law.



Tire Safety Information

Letter Rating	Speed Rating
Q	99 mph
R	106 mph
S	112 mph
T	118 mph
U	124 mph
H	130 mph
V	149 mph
W	168* mph
Y	186* mph

* For tires with a maximum speed capability over 149 mph, tire manufacturers sometimes use the letters ZR. For those with a maximum speed capability over 186 mph, tire manufacturers always use the letters ZR.

U.S. DOT Tire Identification Number

This begins with the letters "DOT" and indicates that the tire meets all federal standards. The next two numbers or letters are the plant code where it was manufactured, and the last four numbers represent the week and year the tire was built. For example, the numbers 3197 means the 31st week of 1997. The other numbers are marketing codes used at the manufacturer's discretion. This information is used to contact consumers if a tire defect requires a recall.

Tire Ply Composition and Materials Used

The number of plies indicates the number of layers of rubber-coated fabric in the tire. In general, the greater the number of plies, the more weight a tire can support. Tire manufacturers also must indicate the materials in the tire, which include steel, nylon, polyester, and others.

Maximum Load Rating

This number indicates the maximum load in kilograms and pounds that can be carried by the tire.

Maximum Permissible Inflation Pressure

This number is the greatest amount of air pressure that should ever be put in the tire under normal driving conditions.

1.5.9.2. UTQGS Information

Treadwear Number

This number indicates the tire's wear rate. The higher the treadwear number is, the longer it should take for the tread to wear down. For example, a tire graded 400 should last twice as long as a tire graded 200.

Traction Letter

This letter indicates a tire's ability to stop on wet pavement. A higher graded tire should allow you to stop your car on wet roads in a shorter distance than a tire with a lower grade. Traction is graded from highest to lowest as "AA", "A", "B", and "C".

Temperature Letter

This letter indicates a tire's resistance to heat. The temperature grade is for a tire that is inflated properly and not overloaded. Excessive speed, underinflation or excessive loading, either separately or in combination, can cause heat build-up and possible tire failure. From highest to lowest, a tire's resistance to heat is graded as "A", "B", or "C".



1.5.9.3. Additional Information on Light Truck Tires

Please refer to the following diagram.

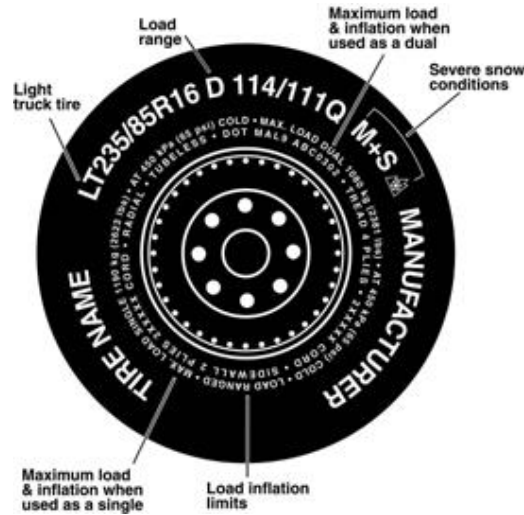

Tires for light trucks have other markings besides those found on the sidewalls of passenger tires.

LT

The "LT" indicates the tire is for light trucks or trailers.

ST

An "ST" is an indication the tire is for trailer use only.

Max. Load Dual kg (lbs) at kPa (psi) Cold

This information indicates the maximum load and tire pressure when the tire is used as a dual, that is, when four tires are put on each rear axle (a total of six or more tires on the vehicle).

Max. Load Single kg (lbs) at kPa (psi) Cold

This information indicates the maximum load and tire pressure when the tire is used as a single.

Load Range

This information identifies the tire's load-carrying capabilities and its inflation limits.

1.6. TIRE SAFETY TIPS

Preventing Tire Damage

- Slow down if you have to go over a pothole or other object in the road.
- Do not run over curbs or other foreign objects in the roadway, and try not to strike the curb when parking.

Tire Safety Checklist

- Check tire pressure regularly (at least once a month), including the spare.
- Inspect tires for uneven wear patterns on the tread, cracks, foreign objects, or other signs of wear or trauma.
- Remove bits of glass and foreign objects wedged in the tread.
- Make sure your tire valves have valve caps.
- Check tire pressure before going on a long trip.
- Do not overload your vehicle. Check the Tire Information and Loading Placard or User's Manual for the maximum recommended load for the vehicle.





Express Potable Water Wagon

Repair Parts

Trailer Frame	26
Axles & Hubs	27
DOT Trailer Lighting	28
Pump & Plumbing	29 - 30
Accessories	31 - 32
Spec Sheet	33



W1245S3

500 Gallon w/Surge Brakes

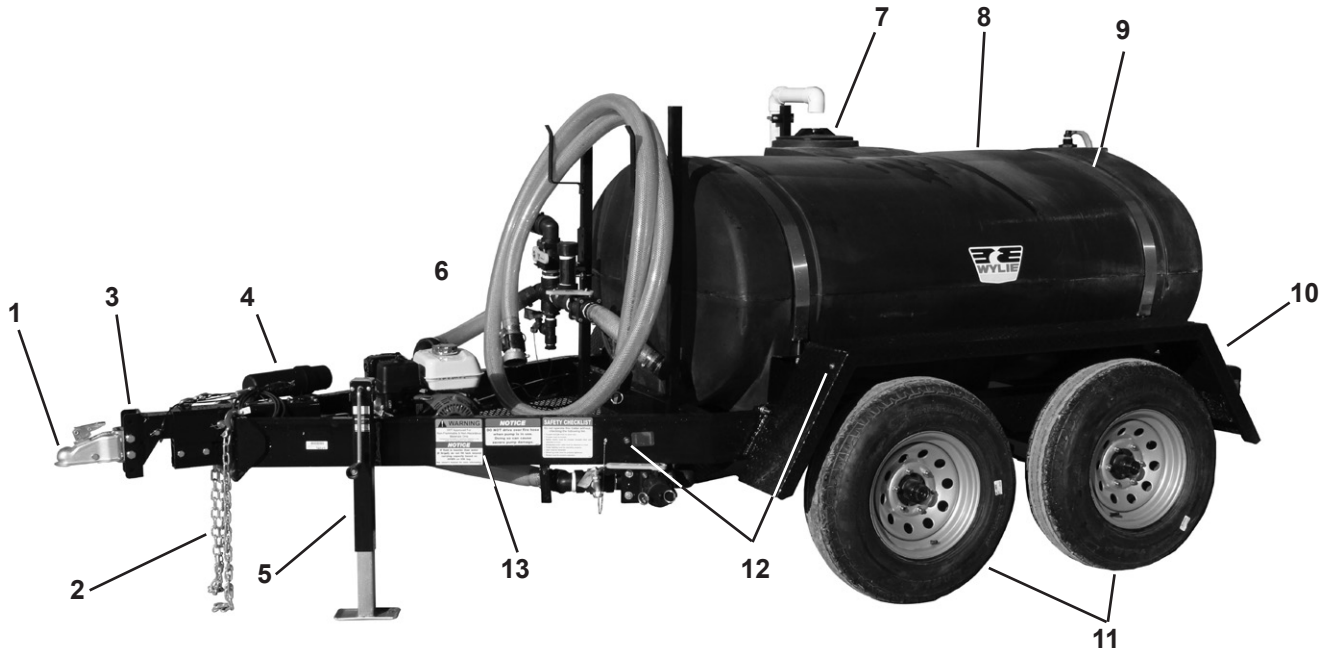

No.	Part No.	Description	No.	Part No.	Description
1	09430-95	2" Ball Hitch	7	TLVA10	10" Tank Lid
2	SC43-49	Safety Chain Kit	8	T500HELBK	500 Gal. Ellip. Leg Tank w/lid
3	8759138	DA91 Surge Brake Actuator	9	W720109	#12-T-2" x 92" (88") Tank Band
	W930233	Breakaway Box Mt Bkt (Elec) (NS)	10	W124547	LH Fender
	50-85-315	Breakaway Elec. Brake System w/Charger (NS)	11	34774	ST225/75D15 Wheel & Tire
4	67670-K	Operator Manual Canister	12	534BAK2B	¾" LED Amber Clearance Marker
5	HD500-SWL-TMR-PZ-M	Side Wind Jack	13	W124546	Frame
6	W124548	RH Fender (NS)	14	W124570	Water Tank Lid Lock (NS)



Axles & Hubs (tandem brake axles)

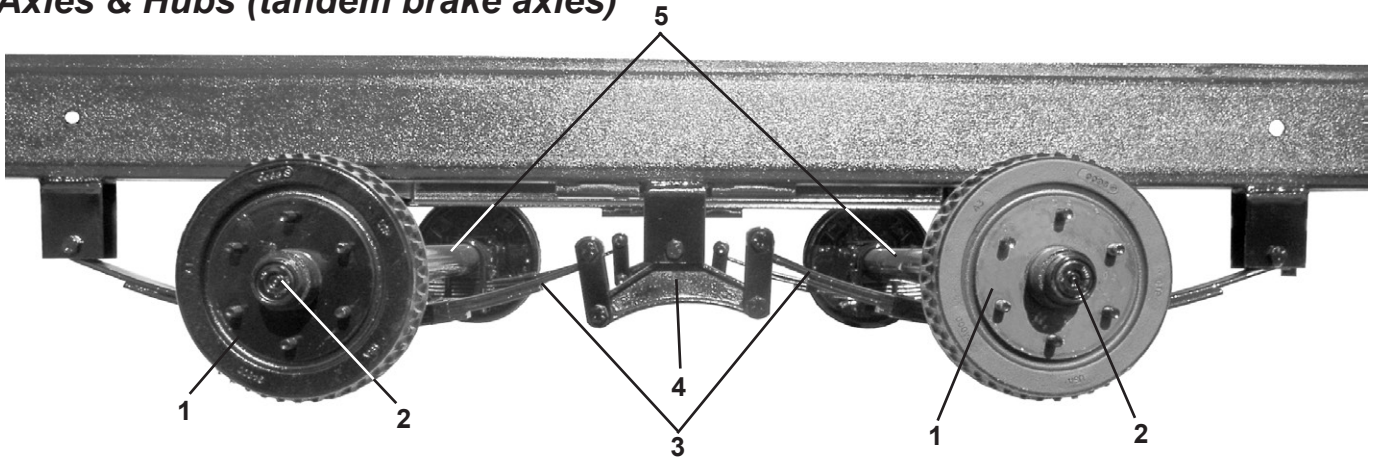

Axle & Hub Parts for 500 Gallon Trailer

No.	Part No.	Description	No.	Part No.	Description
1	4701-L	Electric Brake, 10"-2¼" LH	2F	L-44610	Outer Race, 1.98" OD
	4701-R	Electric Brake, 10"-2¼" RH	2G	L-44649	Outer Bearing, 1.0625" ID
	40716	Surge Brake, 10"-2¼" LH	2H	4753	Spindle Washer, 1"
	40715	Surge Brake, 10"-2¼" RH	2J	4754-Q	Spindle Nut, 1"-14
2	94655	Complete Brake Hub Ass'y.	2K	4755	Cotter Pin, 1/8"x2"
	94655-1	Brake hub w/ cups & studs	2L	RP-100	Rubber Plug, Accu-Lube Grease Cap
2B	4-12	Brake Flange	3	4342-17	Spring, Double Eye, 1700#
2C	171255TB	Grease Seal, single lip, 1.709"	4	4102-A	Tandem Hanger Kit
2D	L-68149	Inner Bearing, 1.375" ID	5	TS35705525655EBX	3,500# Elect. Brake Axle w/AccuLube hubs
2E	L-68111	Inner Race, 2.362" OD		TS35705525655FBX	3,500# Surge Brake Axle w/AccuLube hubs



Front

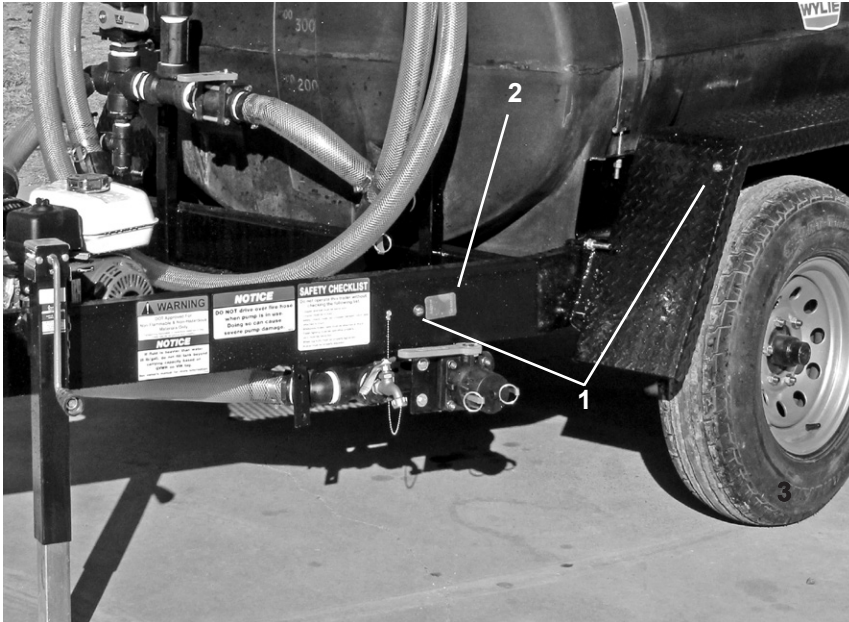

Rear

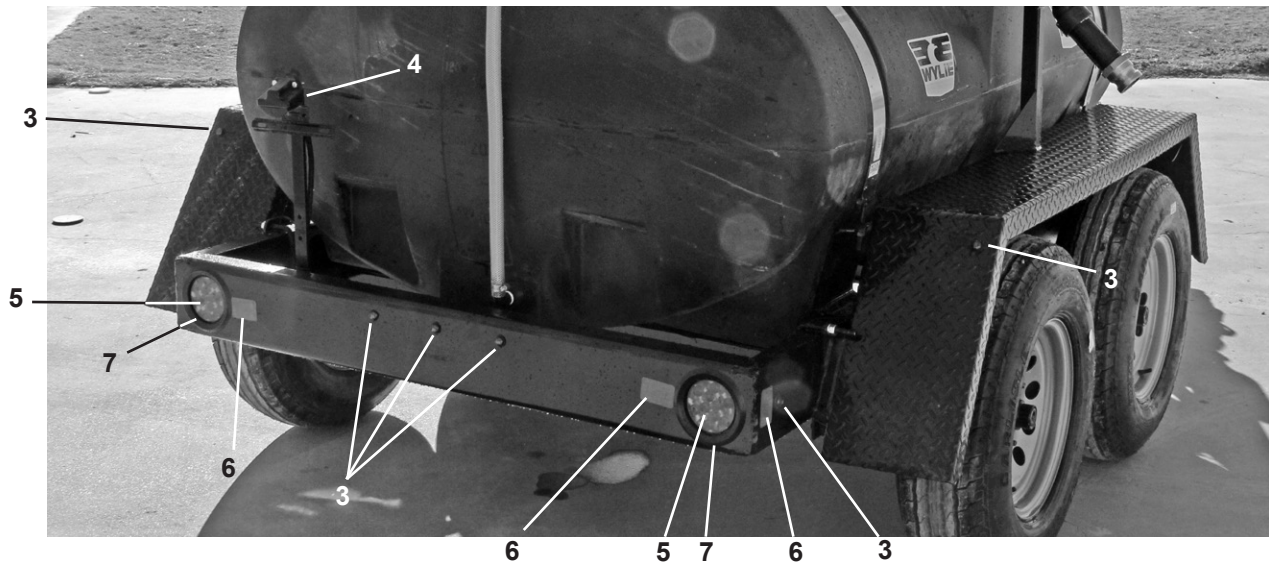

No.	Part No.	Description	No.	Part No.	Description
1	534BAK	¾" LED Amber Clearance	5	542BR	4" Round LED Stop Light
2	88BA	Amber Reflector	6	88BR	Red Reflector
3	534BRK	¾" LED Red Clearance	7	95227	4" Round Grommet
4	223210	License Plate Light Assy.			

Stainless Steel Pump w/ Honda Engine & Plumbing 81570NSF-PK

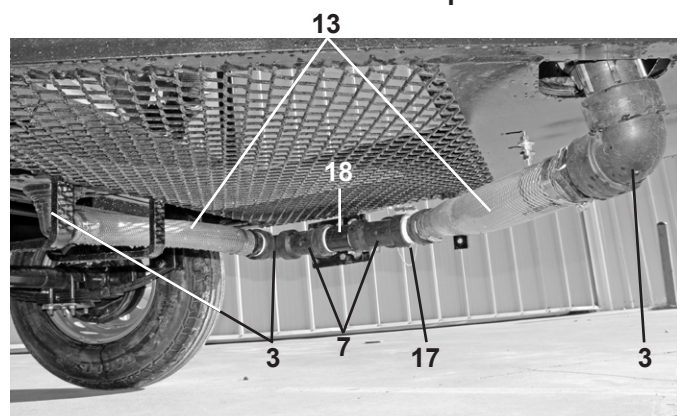
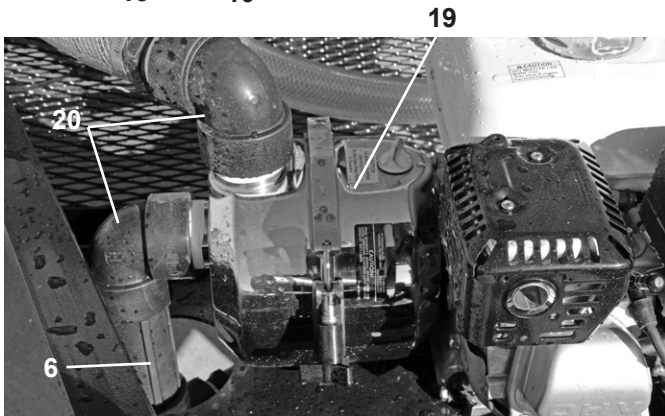
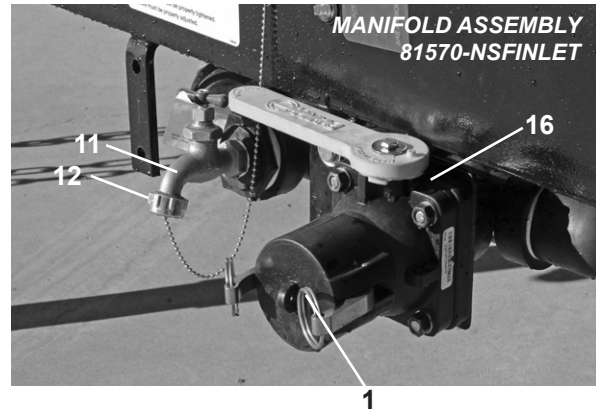
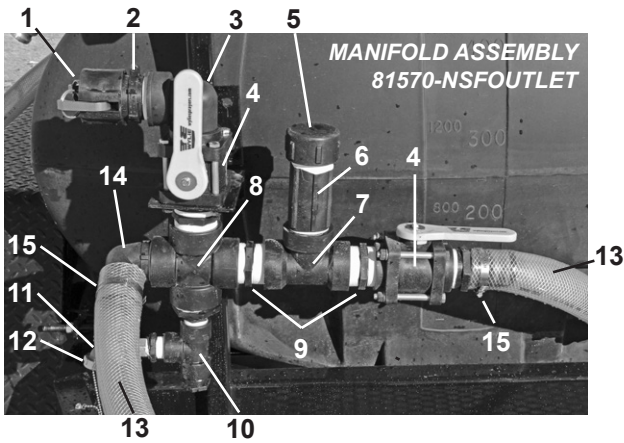

No.	Part No.	Description	No.	Part No.	Description
1	200-CAP-PP	2" POLY DUST CAP w/LEVERS	17	SL200-45	2" PP STREET ELBOW 45 DEGREE
2			18	NIP200-4	2" X 4" POLY PIPE NIPPLE
3	SL200-90	2" POLY PIPE STREET ELBOW	19	IPW2WLE5HCP	SS POTABLE WATER PUMP
4	V-200	2" BALL VALVE			
5	CAP200	2" POLY PIPE CAP			
6	NIP200-6	2" X 6" POLY PIPE NIPPLE			
7	TEE200	2" POLY PIPE TEE			
8	CR200	2" POLY CROSS			
9					
10	TEE100	1" POLY PIPE TEE			
11	0190166IL	3/4"HOSE BIB - LEAD FREE			
12	63745T94	GARDEN HOSE CAP w/CHAIN			
13	K3150-32X100	2" CLEAR FOOD GRADE HOSE			
14					
15	1036	2" STANDARD HOSE CLAMP			
16	VSFMT204FP	2" FP STUBBY VALVE			

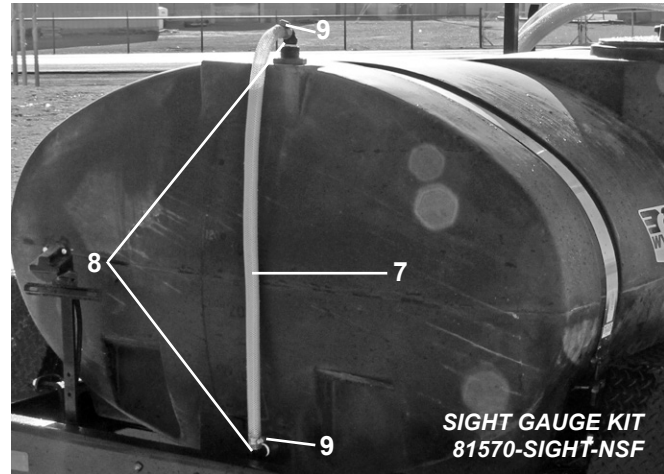
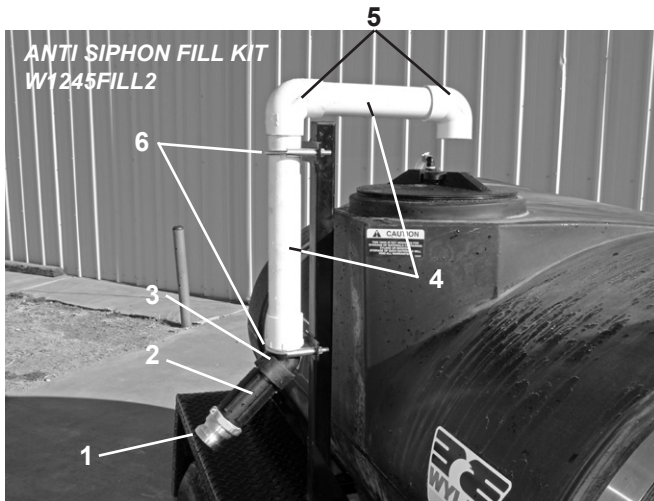

No.	Part No.	Description	No.	Part No.	Description
1	AL-A200	ALUMINUM PART A 2" MALE QC	6	W1245FILL-BK	BOLT KIT
2	NIP200-6	2" X 6" POLY PIPE NIPPLE	7	K3155-12	3/4" CLEAR BRAIDED TUBING
3	SL200-45	2" PP STREET ELBOW 45 DEG.	8	HB075-90	3/4" MALE THREAD X 3/4" HB
4	2"PVC PIPE	2" PVC PIPE, SCH 40	9	1008	1/2" STANDARD HOSE CLAMP
5	406-020	2" 90-DEGREE PVC ELBOW,SCH 40	10	W124570	EXP-500 POTABLE WTR TANK LOCK





SPRAYBAR-EXP-500R2

Spray Bar Kit (Optional)

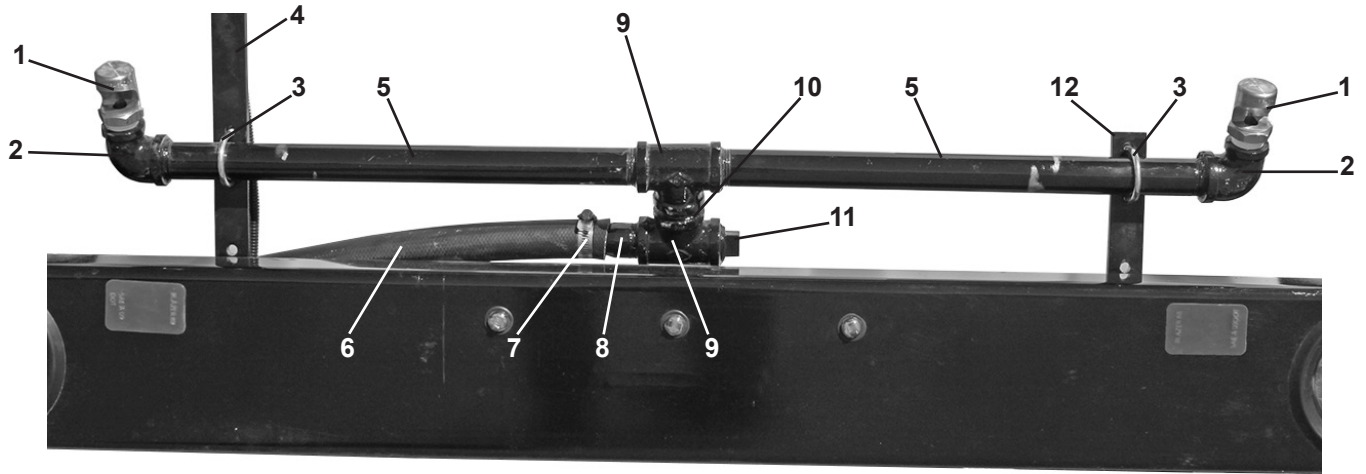

No.	Part No.	Description	No.	Part No.	Description
1	3/4FF484145	Brass Flood Nozzle	7	1028	1½" Hose Clamp
2	90L-10034G	1" x ¾" Elbow 90°, Galv.	8	SPN100	1" MPT x 1" HB
3	U1/4X11/2X23/4	U-Clamp 1½"	9	TEE-100G	1" Tee Galv.
4	W124541	License Plate Bracket	10	NP100-CLOSEG	1" Close Galv. Nipple
5	NP100-18G	1" x 18" Galv. Nipple	11	PLG1G	1" Galv. Plug
6	2-150-100	1" Rubber Hose	12	W124542	Spraybar Mount Bracket

EXP-500-FH

Hose Reel Kit (Optional)

No.	Part No.	Description
1	W124564	Hose Reel A-Frame Support
2	W124563	Hose Reel Mount
3	12-B	½"x3" Bent Pull Pin
4	V0169	2" UHMW Washer
5	W930242	Hose Reel Swivel Base
6	1"x50' RT Hose MC	1"x50' Hose Assembly
7	1175-6-100	Hose Reel
8	FN150	Fire Nozzle
9	901EBV-100	1" Brass Ball Valve
10	SPN100	1" MPT x 1" HB Nipple
11	1028	1½" Hose Clamp
12	2-150-100	1" Rubber Spray Hose

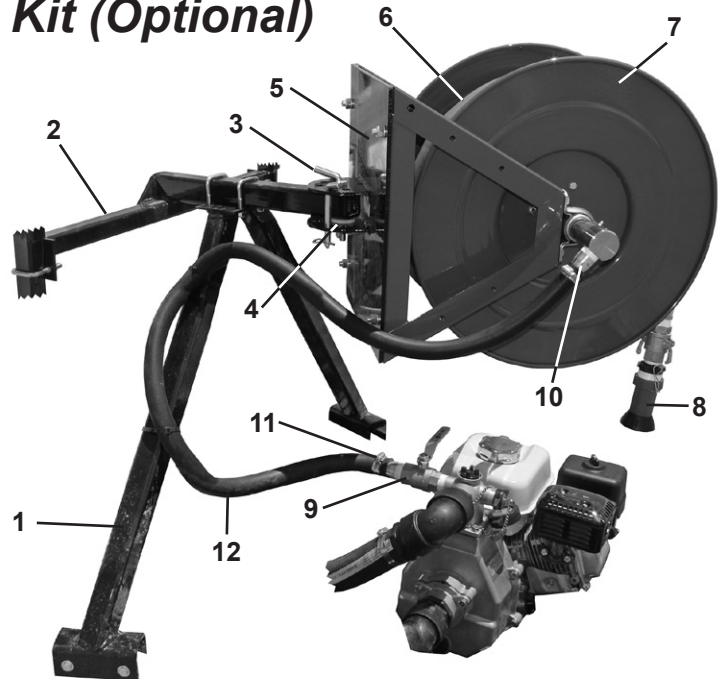



81570-FILL

Suction Kit

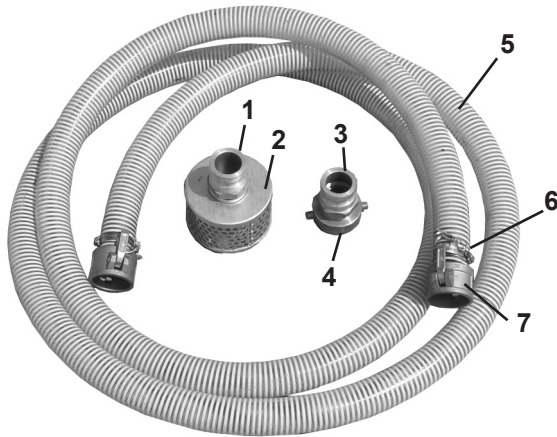

No.	Part No.	Description
1	AL-F200	2" AL Quick Coupler x 2" MPT
2	RHS200	2" Round Hole Strainer
3	AL-A200	2" AL Quick Coupler Adapter
4	09-130-9	Fire Hydrant Adapter
5	7-070-200	2" PVC Suction Hose
6	1036	2" Standard Hose Clamp
7	AL-C200	2" AL Quick Coupler x 2" HB

**Fire Hose Assembly
P/N: BMX25QC**



No.	Part No.	Description
1	AL-D200	2" AL Quick Coupler
2	FN150	1½" Fire Nozzle
3	BMX25QC	1½" Flat Fire Hose Ass'y.

**Side Watering Kit
W5307-FAN**



No.	Part No.	Description
1	AL-D200	2" AL Quick Coupler
2	W530702	2" Fan Spray Nozzle

84503

Garden Hose Kit

No.	Part No.	Description
1	573TF	Pistol Grip Hose Nozzle
2	98108797	5/8" x 25' Water Hose

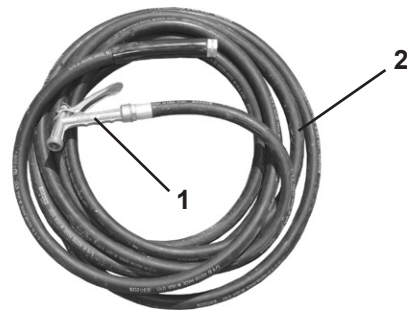



POTABLE DRINKING WATER TRAILER



DRINKING WATER WHERE YOU NEED IT, WHEN YOU NEED IT

Specifications	
Capacity	500 Gallons (FDA Approved & NSF/ANSI Certified Poly Tank w/lid lock)
Pump	2" Stainless Steel with Honda (NSF/ANSI 61 & 372 Certified)
Maximum Flow Rate	180 Gallons Per Minute
Hoses & Plumbing	All Hoses Are Certified Food Grade. All Plumbing Is Compatible With Potable Drinking Water.
Fill	2" Anti-Siphon with 20' of 2" Hose
Garden Hose Spigots	1 Gravity and 1 Pressure
Hitch	2" Ball or 3" Pintle
Trailer	DOT Approved with Surge Brakes
Axles/Brakes	Tandem Spring/Surge
Tires	ST225/75D15
GVWR	6,000 lb
Empty Weight	1,800 lb
Length X Width X Height	L 161" X W 79" X H 66"
Options	Hose Reel with 1" X 50' Hose
	Rear Spray Bar with 2 Spray Nozzles

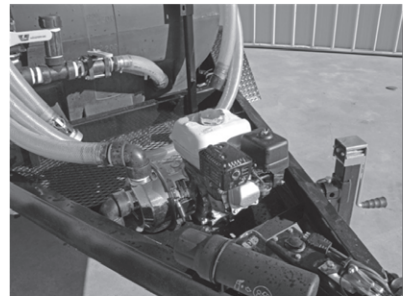

Visit www.WylieSprayers.com to find a location nearest you!

2021 – Wylie Manufacturing Company
Specifications Subject To Change Without Notice