



Express Combo Trailer Express Water Distribution Trailer Express Generator Trailer Repair Parts

Express Combo Trailer Parts

Combo Trailer	52
Fuel Tank	53
Pump Plumbing	54
Tank Plumbing	55
Lights and Brake System.....	56

Express Water Distribution Trailer Parts

Water Distribution Trailer	57
Pump Plumbing	58
Tank Plumbing	59
Freeze Protection Box.....	60
Lights and Brake System.....	61

Express Generator Trailer Parts

Generator Trailer	62
Pump Plumbing	63
Tank Plumbing	64
Electrical Connection Box.....	65
Fuel Tank	66
Lights and Brake System.....	67

All Trailers

Tires & Axles.....	68
7,000 lb Axle Assembly.....	69
Wiring Schematic.....	70



Combo Trailer

EXP-500/COMBO-SC

500 Gal. Combo Trailer

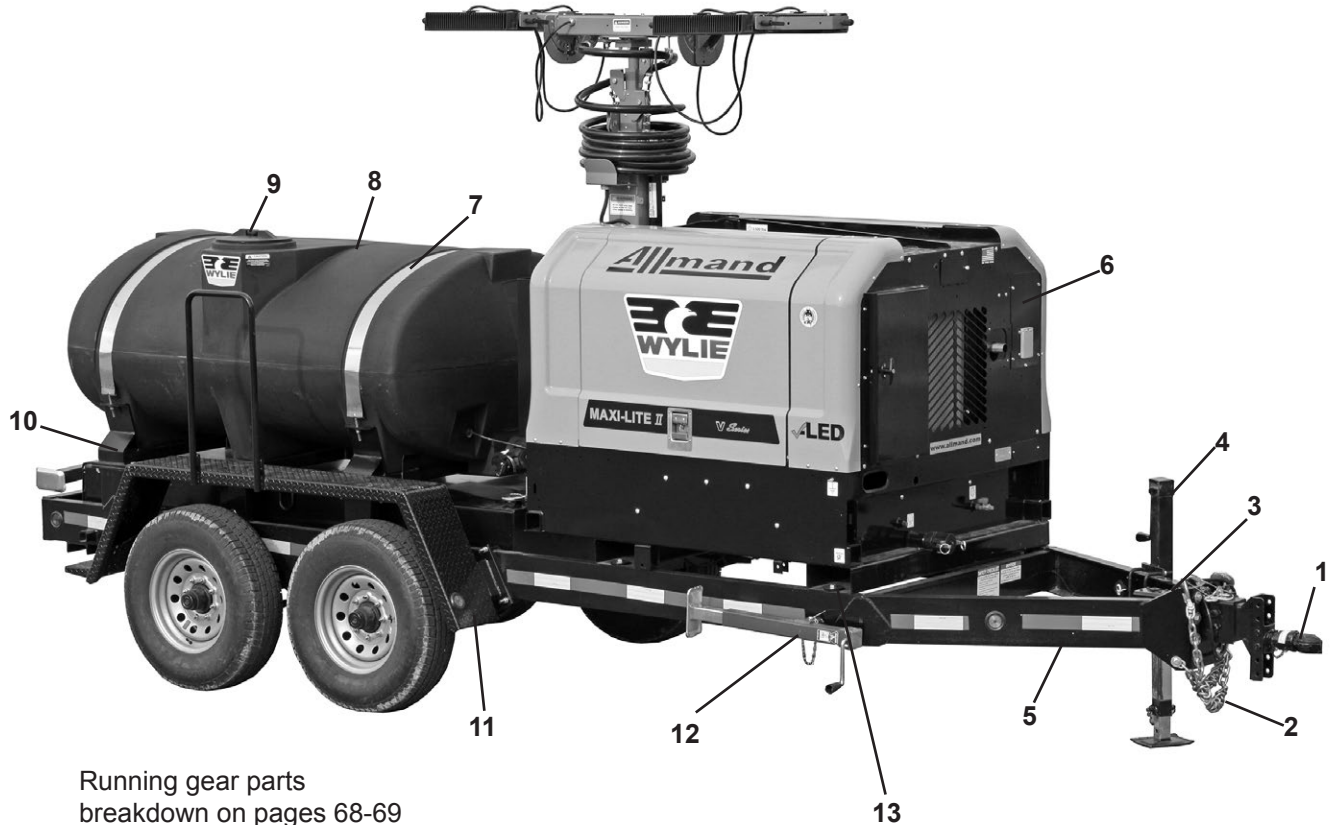

Running gear parts
breakdown on pages 68-69

No.	Part No.	Description	No.	Part No.	Description
1	W-028657	15K Coupler, 2 5/16"	8	T500HELBK	500 Gal. Poly Tank, Black
2	SC70-49	Safety Chain	9	TLV10R	10" Lid
3	W121121	20,000 lb Surge Brake Actuator	10	W144005	Water Tank Support Frame
4	W144006	Drop Leg Jack	11	W144002	Combo Trailer Fender
5	W144001	Trailer Frame	12	35SQ15F-00	3000# Sidewind Jack
6	MLSKIDLED1.5	ML II 13 Kw Generator w/ LED lights	13	W144008	Generator Pad Washer
7	W720145	#69-T-3"x94" Tank Band			

Fuel Tank - 500 Gal. Combo Trailer

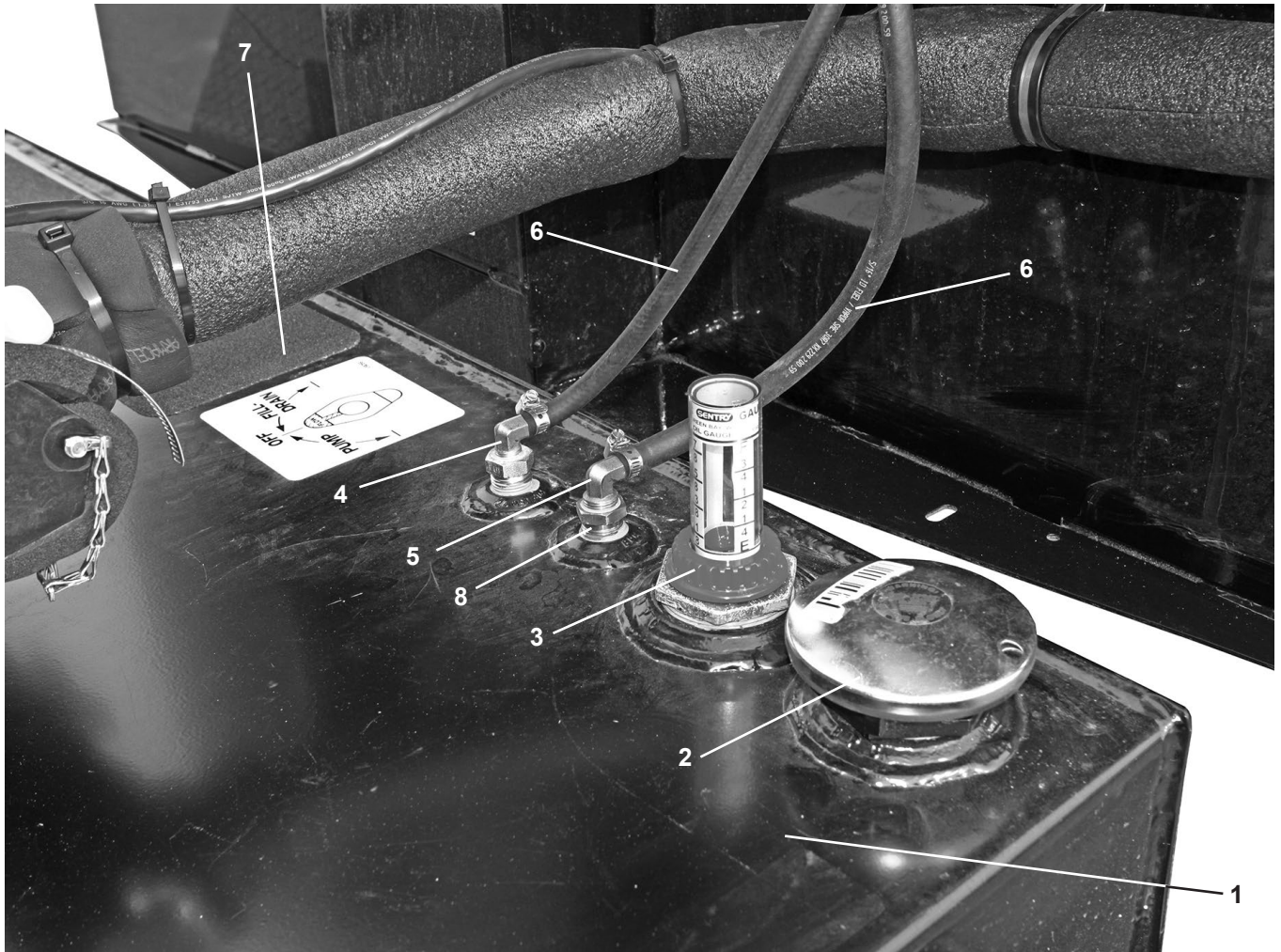

No.	Part No.	Description	No.	Part No.	Description
1	501001	240 Gal. Diesel Fuel Tank	5	32-310	5/16" HB x 3/8" MPT Brass Elbow
2	60001	Vented Fuel Cap	6	5/16-P2	5/16" Red Diesel Hose
3	D-2-13.5	Fuel Level Gauge	7	7781T35	Anti-slip 6"x24" Self-Adhesive
4	32-039	1/4" HB x 1/4" MPT Brass Elbow	8	FTA-DT-14.49	Standpipe, Brass



Pump Plumbing -- 500 Gal. Combo Trailer
For Trailers With Serial Numbers Above 051695 (inclusive)

(shown with optional freeze protection kit)

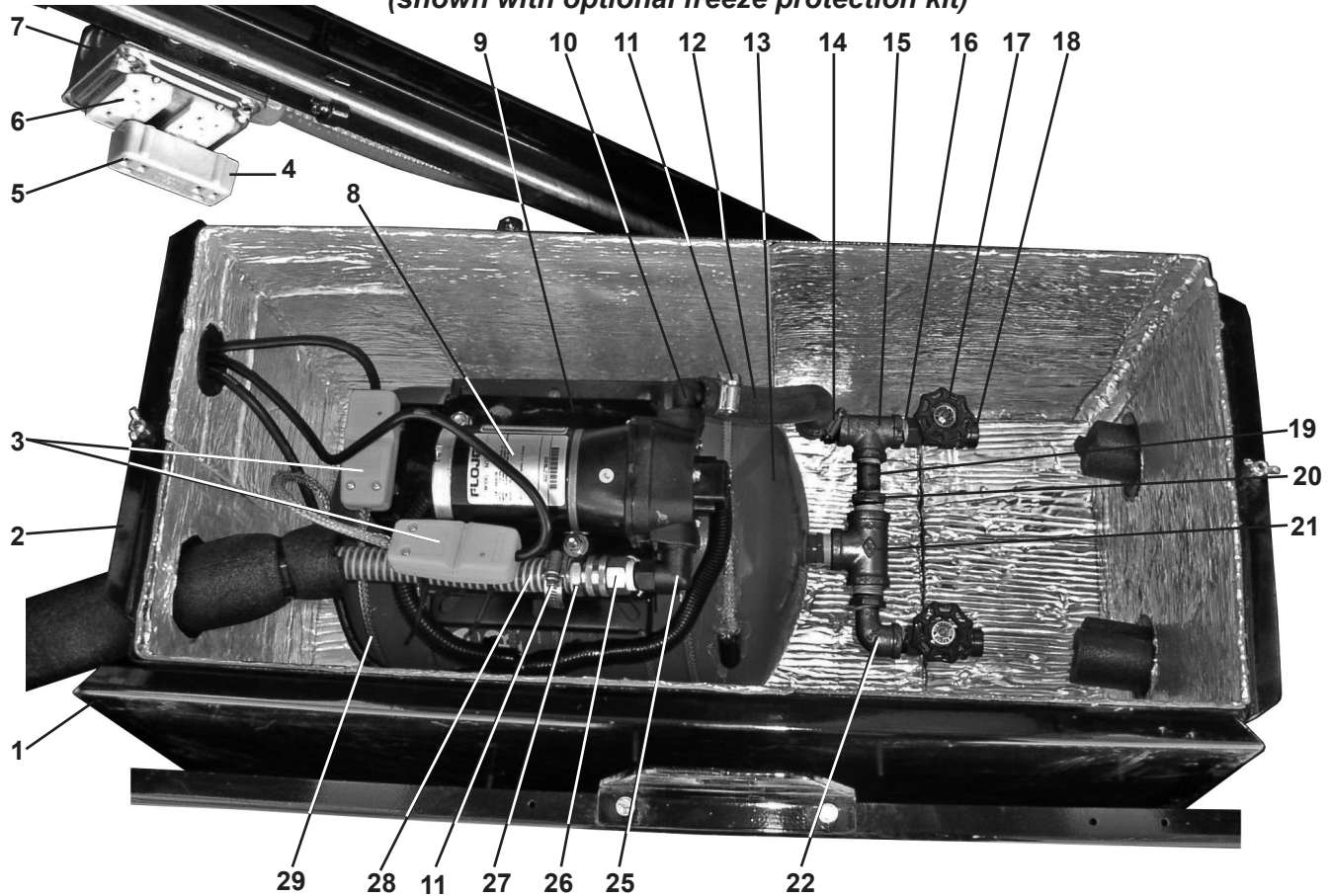

No.	Part No.	Description	No.	Part No.	Description
1	W140012	Pump Box Lid	14	HB050/075-90	½" MPT x ¾" HB, 90° Poly
2	W144011	Pump Box	15	TEE-12G	½" Tee Galv.
NS	W144013	Base Plate	16	NP12-CLOSEG	½" Close Nipple Galv.
3	MS5432	Easy Heat Connection Kit	17	BV-012	½" Brass Gate Valve
4	TC-3	Thermocube Outlet	18	E3412B	¾" MGHT x ½" MPT Adapter
5	2095-W	20 AMP GFCI Duplex Outlet	19	NP12-2G	½" x 2" Nipple Galv.
6	TP511	4SQ Cover F/2 GFCI	20	RB-3412G	¾" x ½" Reducer Bushing Galv.
7	TP403	4SQ 2-1/8D Box	21	TEE-34G	¾" Tee Galv.
8	4300-043A	115V Flojet Pump	22	90STL-12G	½" Street Elbow Galv.
9	W144009	Pump Mount Plate	25	20381-047	Port Kit, ½" MPT, 90°
10	20381-010	Port Kit, ¾" EL	26	S-1-BR	½" FPT Swivel x ¾" FGHT
11	1012	¾" Hose Clamp	NS	3800-0035	Garden Hose Screen
12	2-200-075	¾" Rubber Hose	27	D-3434-BR	¾" MGHT x ¾" Hosebarb
13	HT6HB	6 Gallon Pressure Tank	28	7-090-075	¾" PVC Suction Hose
			29	MS5490	Heat Cord

Tank Plumbing -- 500 Gal. Combo Trailer
For Trailers With Serial Numbers Above 051695 (inclusive)
(shown with optional freeze protection kit)

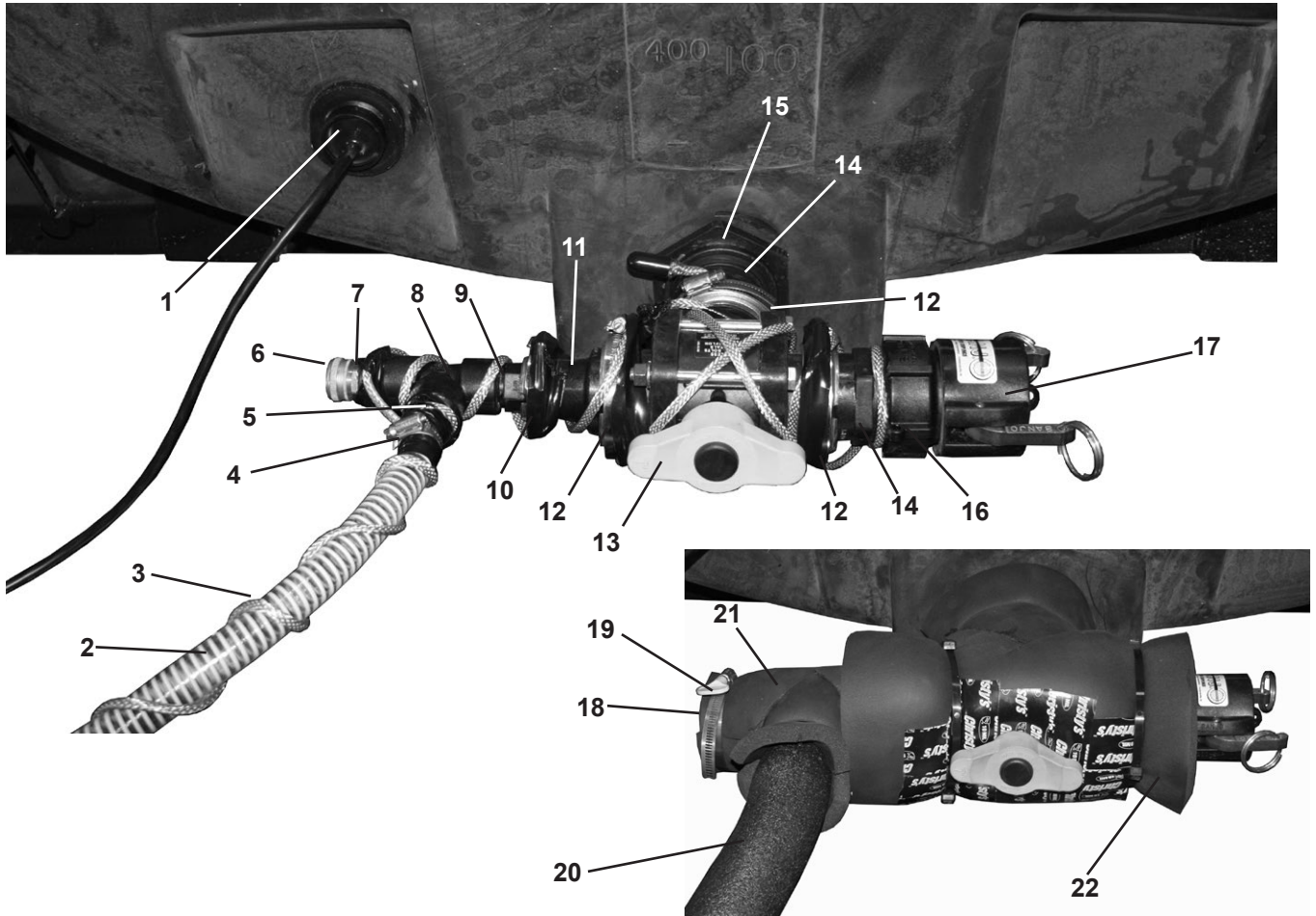

No.	Part No.	Description	No.	Part No.	Description
1	DPH-15	Tank Heater	12	FC200	2" Flange Clamp
2	7-090-075	3/4" PVC Suction Hose		150G	2" EPDM Gasket
3	MS5490	Heat Cord	13	MV200BL	2" 3-Way Bottom Load Valve
4	1012	3/4" Hose Clamp	14	M200MPT	2" Flange x 2" MPT
5	HB-075	3/4" Hose Barb	15	60405	2" Bulkhead Fitting
6	70136	Hose Cap, Brass	16	200-A-PP	2" QC Male Adapter, 2" FPT
7	E34B	3/4" MGHT x 3/4" MPT	17	200-CAP-PP	2" QC Cap
8	TEE075	3/4" Poly Tee	18	PLUG200	2" Poly Plug
9	M100075MPT	1" Flange x 3/4" MPT	19	5362K34	4" Thumbscrew Hoseclamp
10	FC100	1" Flange Clamp	20	IR6200	1 3/8" ID Foam Pipe Insulation
	M100G	1" EPDM Gasket	21	93715K121	Foam Insulation Tee
11	M200100CPG	2"x1" Flange Coupling	22	93715K128	Foam Insulation Tee



Combo Lights

Lights & Brake System - 500 Gal. Combo Trailer

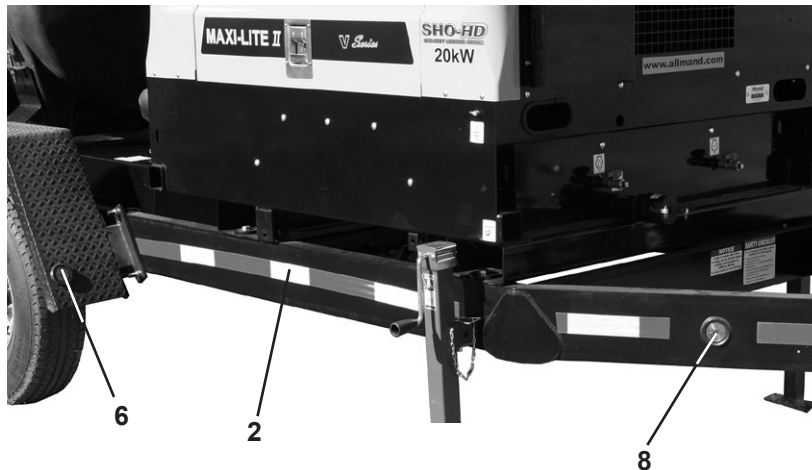
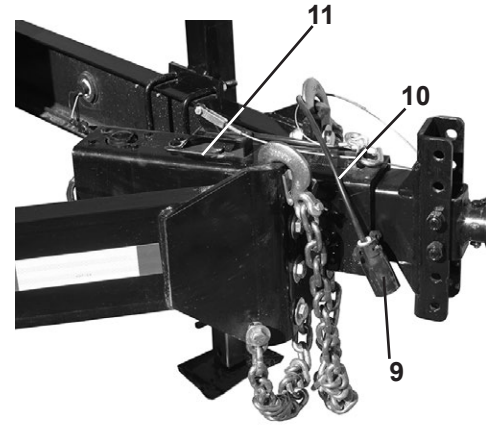
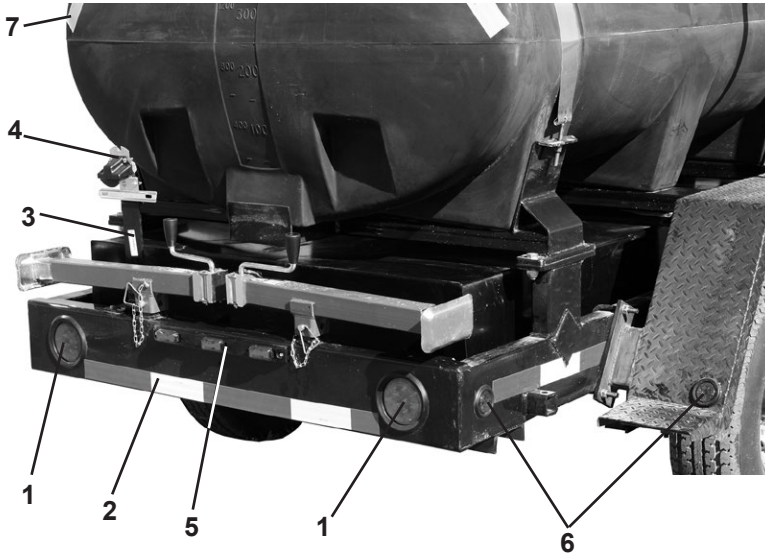

No.	Part No.	Description	No.	Part No.	Description
1	J-45-RK	4" LED Red Stop, Turn Light	7	TMP-W200-12	White Reflective Tape, 2"
2	TMP-3M-980-02	Red & White Reflective Tape	8	A203K	2" LED Amber Side Marker Light
3	W144007	License Plate Bracket	9	5077003	7 Pole Trailer Connector
4	223210	License Plate Light Ass'y.	10	91465	14 Ga. 6 Conductor Wire
5	CPL26R-3 BAR	LED 17" ID Light	11	W121121	20,000 lb Surge Brake Actuator
6	R203K	2" LED Red Side Marker Light			

EXP-1025-22GPM 1,025 Gal. Water Distribution Trailer

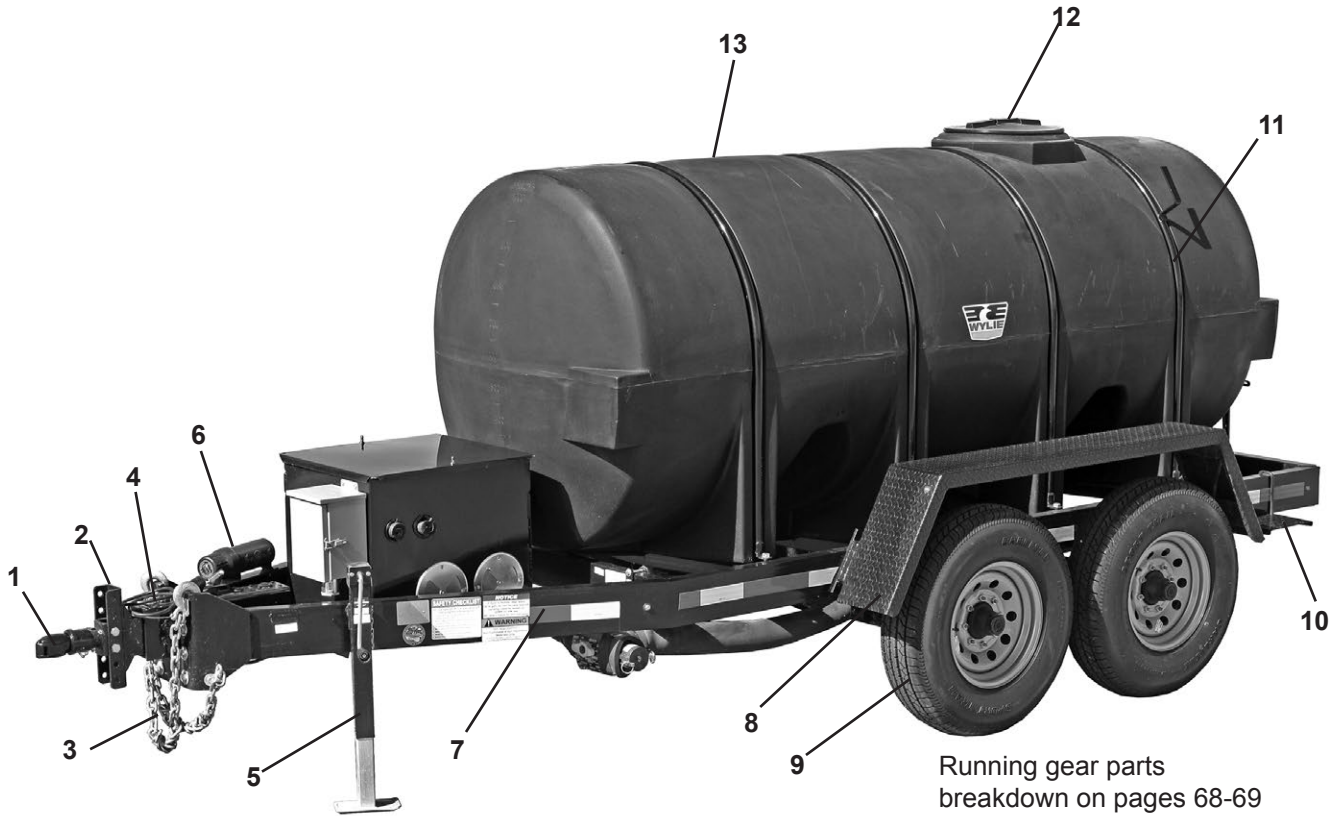

Running gear parts
breakdown on pages 68-69

No.	Part No.	Description	No.	Part No.	Description
1	W-028657	15K Channel Coupler, 2 5/16"	8	W124113	LH Fender
2	W930150	2" Coupling Bracket		W124114	RH Fender (not shown)
3	SC70-49	Safety Chain Kit	9	457861	ST225/90D16 Tires
4	W121121	20,000 lb Surge Brake Actuator	10	W1241-STEP	Bolt-on Step
5	HD500-SWL-TMR-PZ-M	5000# Sidewind Jack	11	W120511	Tank Hoop
6	67670	Operator's Manual Canister	12	352060	18" Tank Lid
7	W124111	Trailer Frame	13	T1025LSBK	1,025 Gal. Black Leg Tank



Pump Plumbing -- 1,025 Gal. Water Distribution Trailer

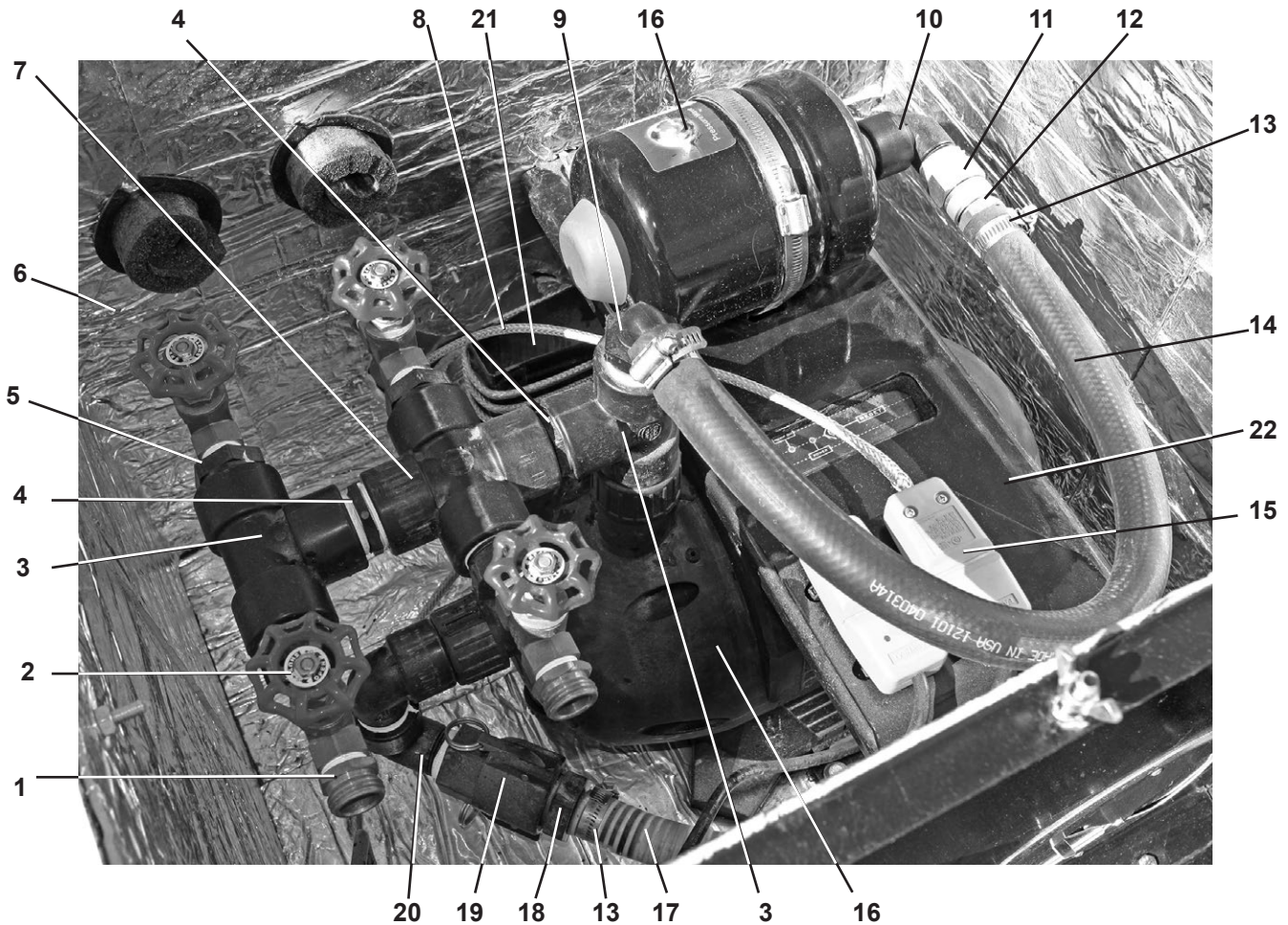

No.	Part No.	Description	No.	Part No.	Description
1	E3412B	3/4" MGHT x 1/2 " MPT Adapter	12	D-3434-BR	3/4" MGHT x 3/4" Hosebarb
2	BV-012	1/2" Brass Gate Valve	13	1016	7/8" Hose Clamp
3	TEE100	1" Poly Tee	14	2-200-075	3/4" Rubber Hose
4	NIP100-SH	1" Poly Short Nipple	15	MS5432	Freeze Free Connection Kit
5	RN100-050	1" x 1/2" Poly Reducer Nipple	16	BFDD2714858	22 GPM Pump & Pressure Tank
6	FV516	Foil and Foam Insulation	17	7-090-100	1" PVC Suction Hose
7	CR100	1" Poly Cross	18	100-E-PP	Male Adapter x 1" HB
8	MS5490	Heat Cord	19	100-D-PP	Female Adapter x 1" FPT
9	HB100/075-90	1" MPT x 3/4" HB, 90° Poly	20	SL100-90	1" Street "L" Poly
10	SL075-90	3/4" Street "L" Poly	21	W124121	Heat Cable Wrap
11	S-2-BR	3/4" FPT Swivel x 3/4" FGHT	22	W124120	Pump Hold Down Plate

Tank Plumbing -- 1,025 Gal. Water Distribution Trailer

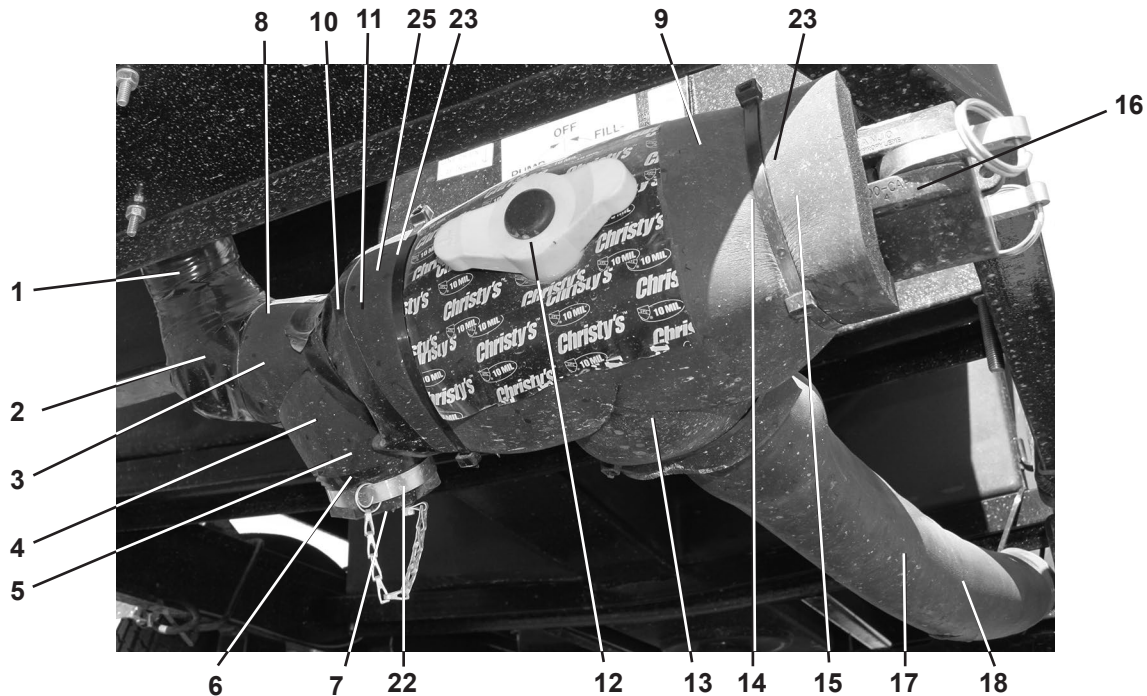

No.	Part No.	Description
1	7-090-100	1" PVC Suction Hose
2	HB100-90	1" MPT x 1" Hosebarb
3	TEE100	1" Poly Tee
4	RB100-050	1"x½" Reducer Bushing
5	E3412B	¾" MGHT x ½" MPT
6	70136	Hose Cap, Brass
7	PLUG200	2" Poly Plug
8	93715K121	Foam Insulation Tee
9	93715K128	Foam Insulation Tee
10	100MPT	1" Flange x 1" MPT
11	FC100	1" Flange Clamp
	M100G	1" EPDM Gasket
12	MV200BL	2" 3-Way Bottom Load Valve
13	M200BRB	2" Flange x 2" Hosebarb
14	M200MPT	2" Flange x 2" MPT
15	200-A-PP	2" QC Male Adapter, 2" FPT
16	200-CAP-PP	2" QC Cap
17	7-070-200	2" PVC Suction Hose
18	4463K144	Foam Pipe Insulation
19	M200CPG90	2" Flange Coupling, 90°
20	93715K19	Foam Insulation Elbow
21	60405	2" Bulkhead Fitting
22	5362K34	4" Thumbscrew Hoseclamp
23	FC200	2" Flange Clamp
	150G	EPDM 2" Flange Gasket
24	1036	2" Hose Clamp
25	M200100CPG	2"x1" Flange Coupling

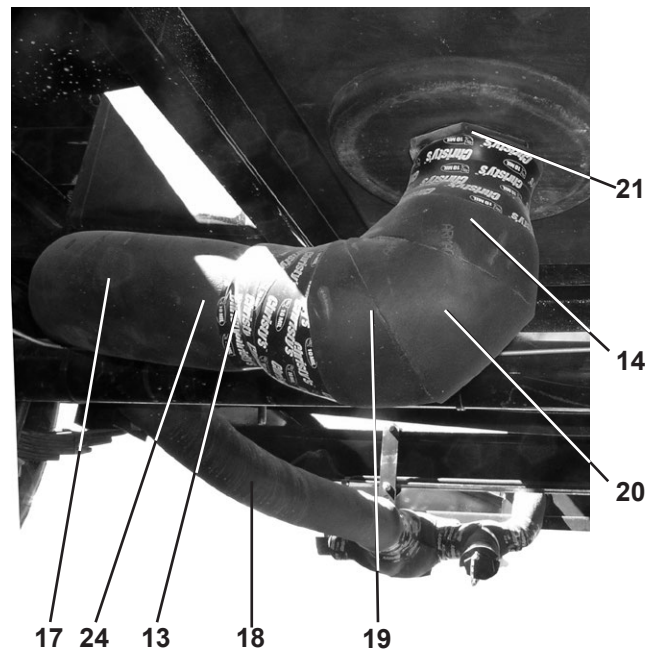

Freeze Protection Box - 1,025 Gal. Water Distribution Trailer

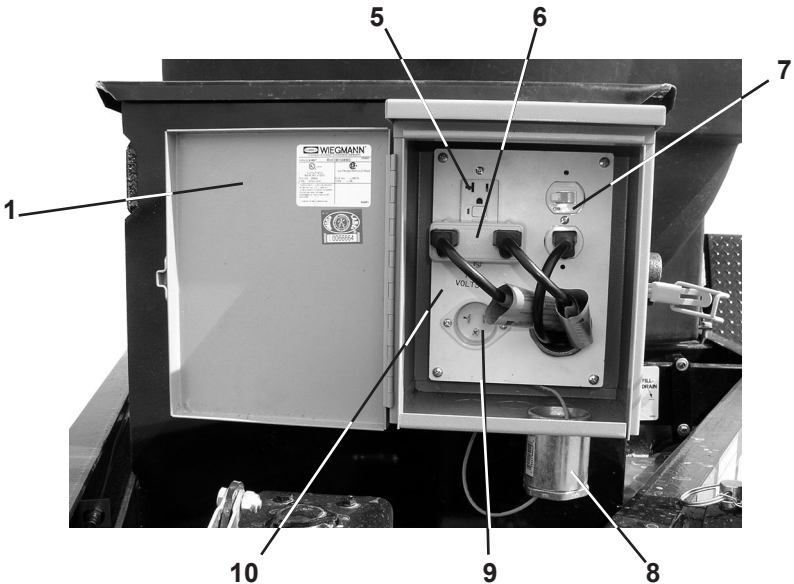
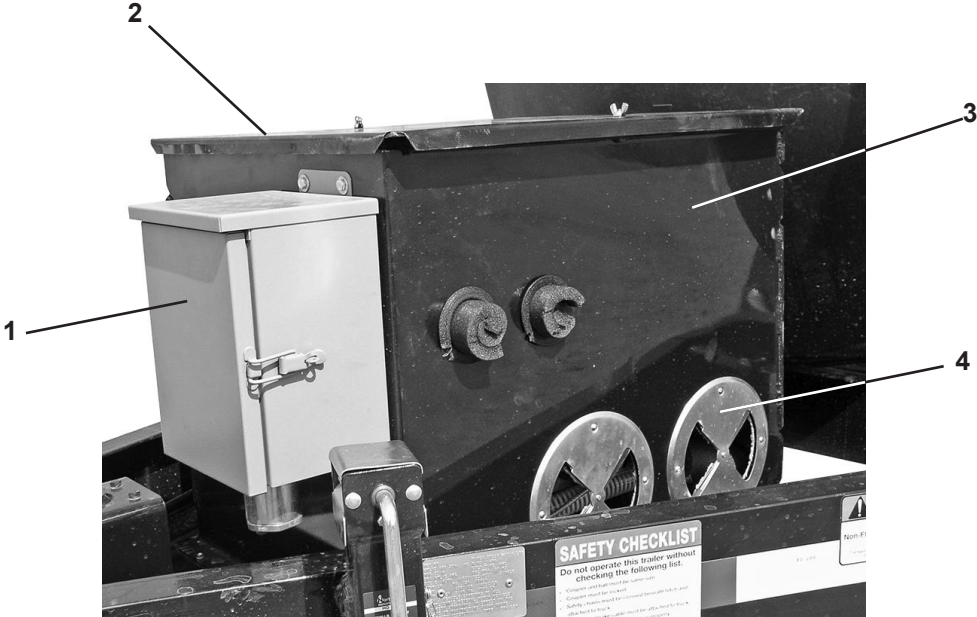

No.	Part No.	Description	No.	Part No.	Description
1	7649K45	Electrical Enclosure 10x8x6	6	TC-3	Thermocube Outlet
2	W124119	Pump Box Lid	7	691W	Switch & Single Plug Receptacle
3	W124118	Pump Enclosure	8	1 1/2-GALV-CPLG	1 1/2" Galv. Conduit Coupling
4	6501	Butterfly Vent	9	5278-SS	Flanged Inlet Plug, 15 Amp
5	2095-W	20 Amp GFCI Outlet	10	V0410	Electrical Enclosure Plate

Lights & Brake System - 1,025 Gal. Water Distribution Trailer

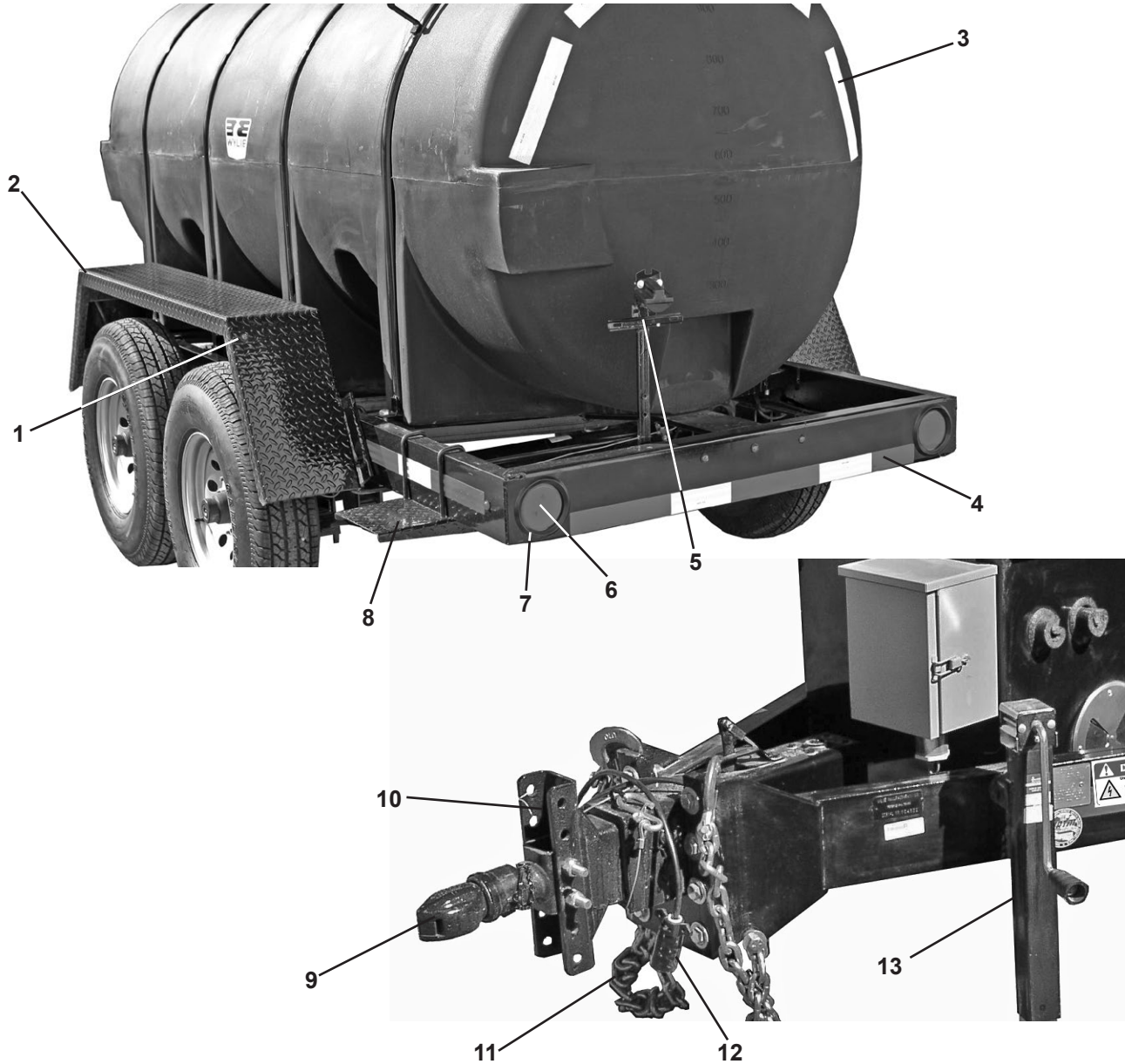

No.	Part No.	Description	No.	Part No.	Description
1	534BRK	¾" Red LED Light	8	W1241-STEP	Bolt-on Step
2	534BAK	¾" Amber LED Light	9	W-028657	15K Channel Coupler, 2 5/16"
3	TMP-W200-12	White Reflective Tape	10	W121121	20,000 lb Surge Brake Actuator
4	TMP-3M-980-02	White/Red Reflective Tape	11	SC70-49	Safety Chain Kit
5	223210	License Plate Light Assembly	12	5077003	7 Pole Connector Plug
6	542BR	4" Round LED Stop/Turn Light	13	HD500-SWL-TMR-PZ-M	5,000 lb Sidewind Jack
7	95227	4" Round Grommet			



Generator Trailer

EXP-500/COMBO-SG14 -- 500 Gal. Generator Trailer

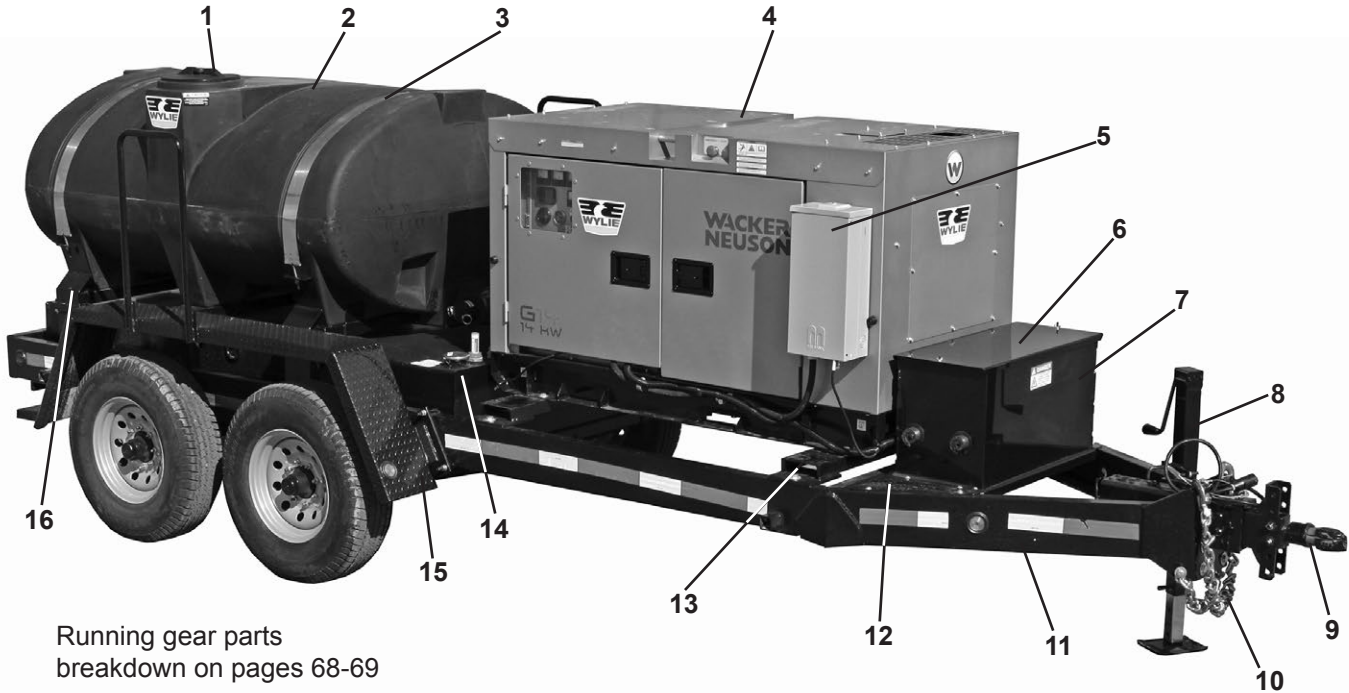

Running gear parts
breakdown on pages 68-69

No.	Part No.	Description	No.	Part No.	Description
1	TLV10R	10" Tank Lid	9	W-028657	15K Channel Coupler, 2 5/16"
2	T500HELBK	500 Gal. Black Poly Tank	10	SC70-49	Safety Chain Kit
3	W720145	#69-T-3"X94" (90") Tank Band	11	W144001	Trailer Frame
4	0620689	G-14 Wacker Neuson Generator	12	W144202	Pump Baseplate
5	U500-XL-75	Power Outlet, 50 Amp & 30 Amp	13	W144201	Generator Mount
6	W144012	Pump Box Lid	14	501001	240 Gal. Diesel Tank
7	W144011	Pump Box	15	W144002	Trailer Fender
8	W144006	Trailer Jack	16	W144005	Water Tank Support Frame

Pump Plumbing -- 500 Gal. Generator Trailer (shown with optional Freeze Protection System)

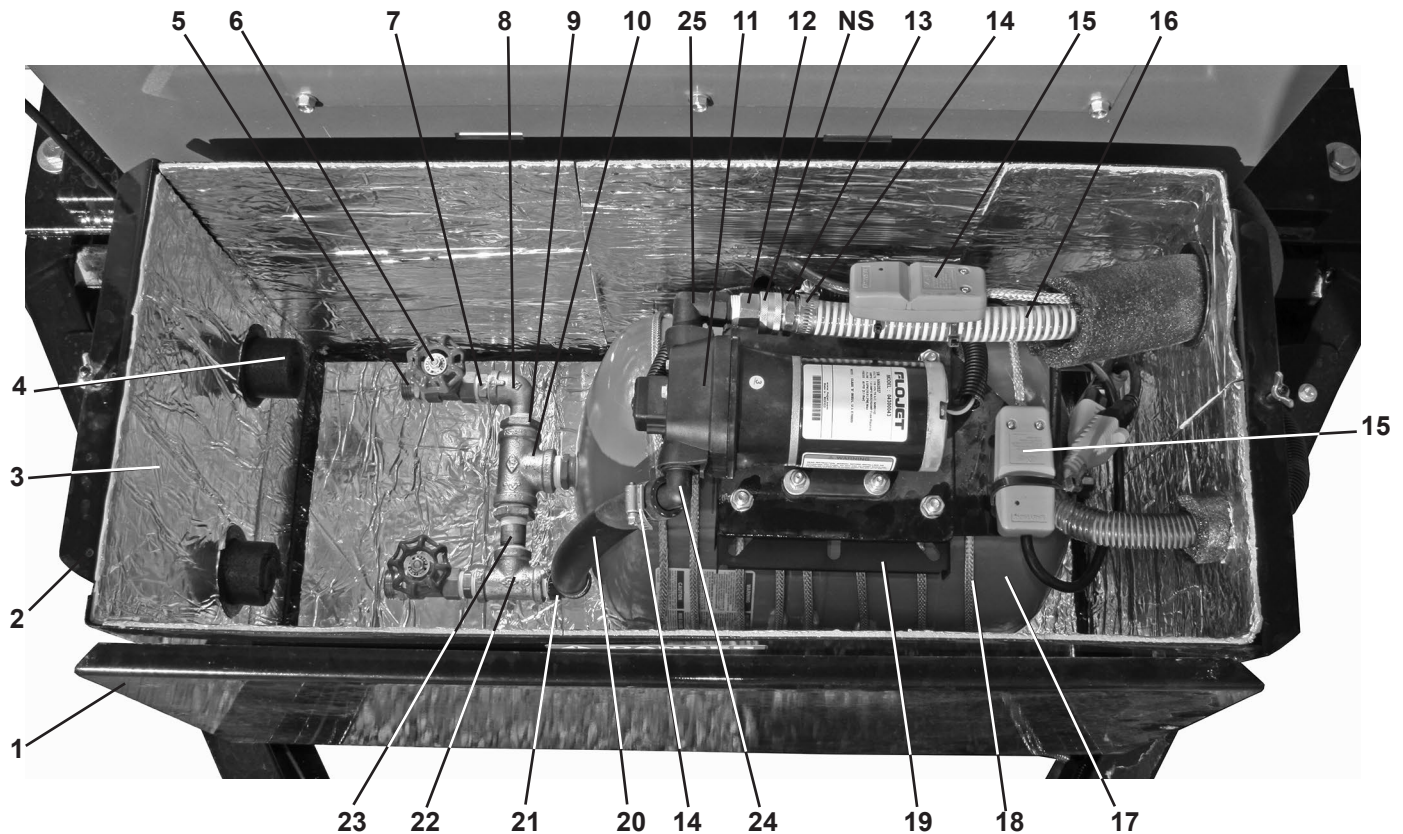

No.	Part No.	Description	No.	Part No.	Description
1	W140012	Pump Box Lid	13	D-3434-BR	3/4" MGHT x 3/4" Hosebarb
2	W144011	Pump Box	14	1012	3/4" Hose Clamp
3	FV516	Foil and Foam Insulation	15	MS5432	Easy Heat Connection Kit
4	IR6200	1 3/8" ID Foam Pipe Insulation	16	7-090-075	3/4" PVC Suction Hose
5	E3412B	3/4" MGHT x 1/2" MPT Adapter	17	HT6HB	6 Gallon Pressure Tank
6	BV-012	1/2" Brass Gate Valve	18	MS5490	Heat Cord
7	122A-D	1/2" Brass Hex Close Nipple	19	W144009	Pump Mount Plate
8	90STL-12G	1/2" Street Elbow Galv.	20	2-200-075	3/4" Rubber Hose
9	RB-3412G	3/4" x 1/2" Reducer Bushing Galv.	21	HB050/075-90	1/2" MPT x 3/4" HB, 90° Poly
10	TEE-34G	3/4" Tee Galv.	22	TEE-12G	1/2" Tee Galv.
11	4300-043A	115V Flojet Pump	23	NP12-2G	1/2" x 2" Nipple Galv.
12	S-1-BR	1/2" FPT Swivel x 3/4" FGHT	24	20381-010	Port Kit, 3/4" EL
NS	3800-0035	Garden Hose Screen	25	20381-047	Port Kit, 1/2" MPT, 90°



**Tank Plumbing -- 500 Gal. Generator Trailer
(shown with optional Freeze Protection System)**

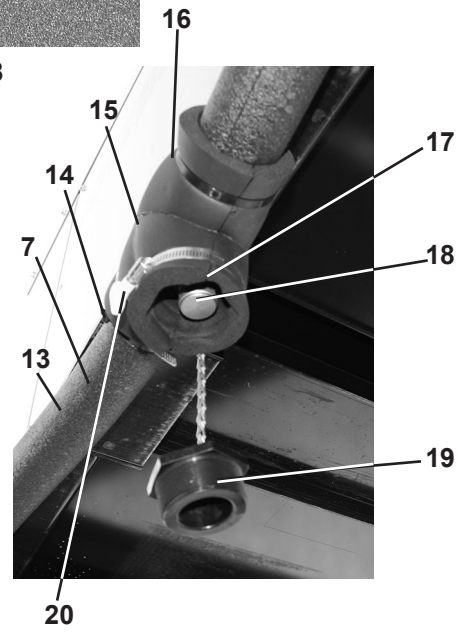
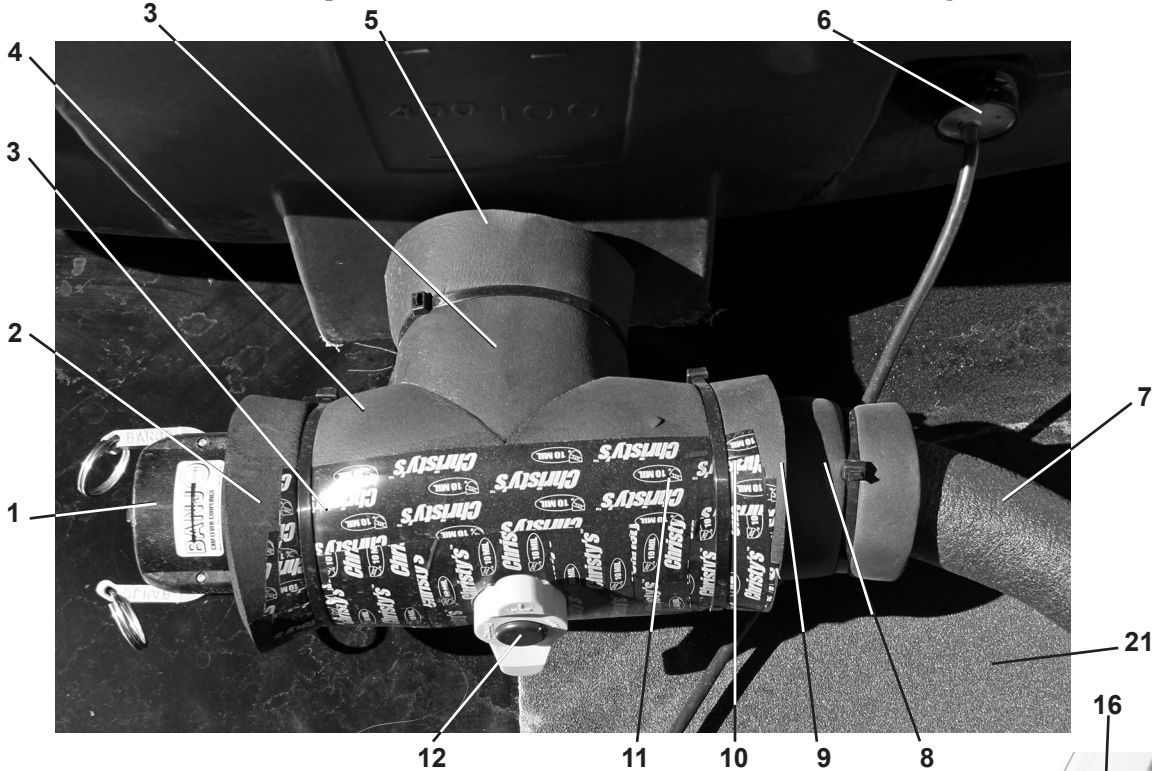

No.	Part No.	Description
1	200-CAP-PP	2" QC Cap
2	200-A-PP	2" QC Male Adapter, 2" FPT
3	M200MPT	2" Flange x 2" MPT
4	93715K128	Foam Insulation Tee
5	60405	2" Bulkhead Fitting
6	DPH-15	Tank Heater
7	7-090-075	3/4" PVC Suction Hose
8	M100075BRB	1" Flange x 3/4" HB
9	FC100	1" Flange Clamp
	M100G	1" EPDM Gasket
10	M200100CPG	2"x1" Flange Coupling
11	FC200	2" Flange Clamp
	150G	2" EPDM Gasket
12	MV200BL	2" 3-Way Bottom Load Valve
13	IR6200	1 3/8" ID Foam Pipe Insulation
14	HB-075	3/4" Hose Barb
15	TEE075	3/4" Poly Tee
16	93715K121	Foam Insulation Tee
17	E34B	3/4" MGHT x 3/4" MPT

No.	Part No.	Description
18	70136	Hose Cap, Brass
19	PLUG200	2" Poly Plug
20	5362K34	4" Thumbscrew Hoseclamp
21	7781T35	Antislip 6"x24"

Electrical Connection Box - 500 Gal. Generator Trailer

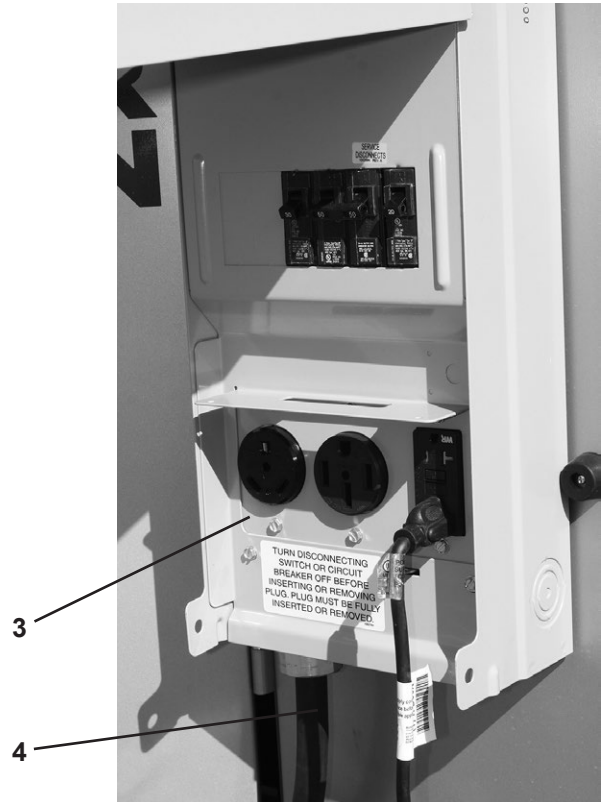
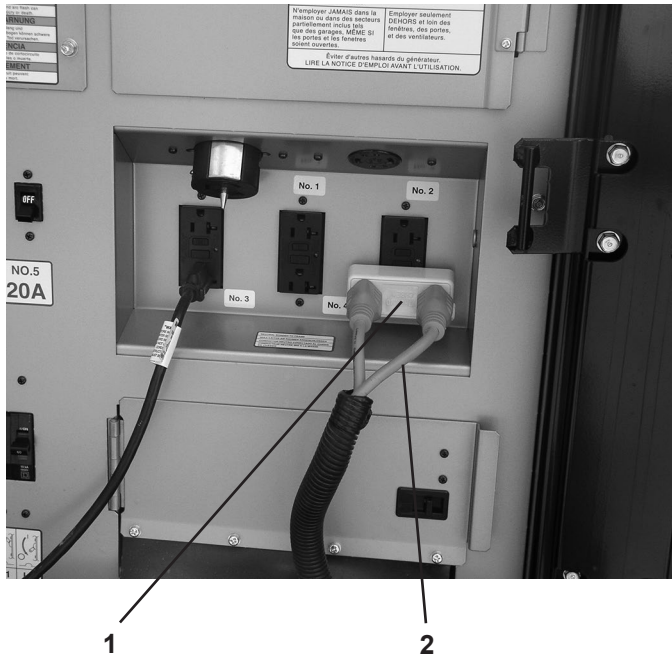

No.	Part No.	Description	No.	Part No.	Description
1	TC-3	Thermocube Outlet	3	U500-XL-75	Power Outlet, 50 Amp & 30 Amp
2	7438K31	Outdoor Ext. Cord, 16 AWG, 10'	4	SOOW-6/4-BLK-250R	4-Wire Conductor Cable



Generator Fuel Tank

Fuel Tank - 500 Gal. Generator Trailer

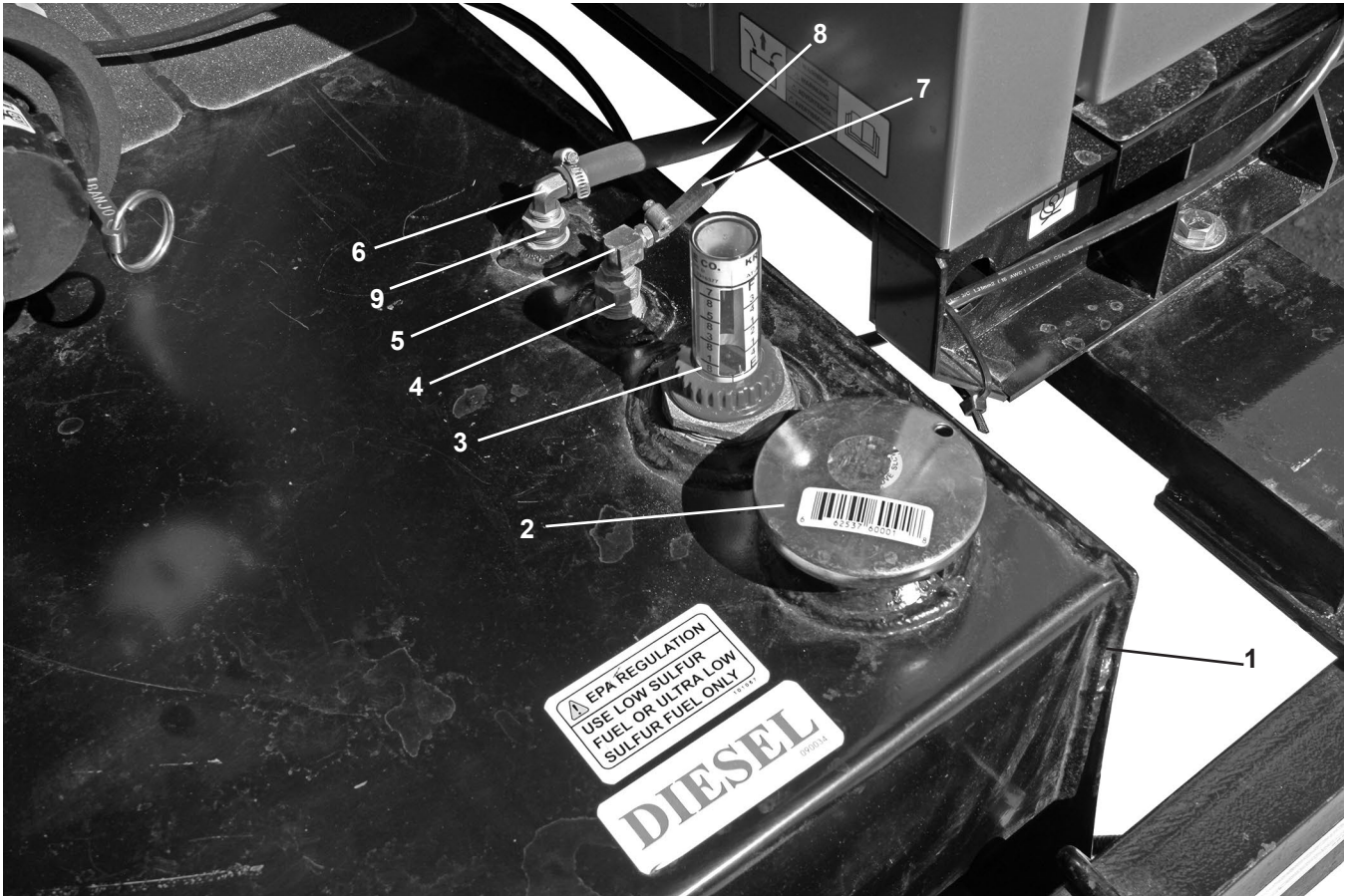

No.	Part No.	Description	No.	Part No.	Description
1	501001	240 Gal. Diesel Fuel Tank	5	4290-02-04	1/8" HB x 1/4" MPT Brass Elbow
2	60001	Vented Fuel Cap	6	32-310	5/16" HB x 3/8" MPT Brass Elbow
3	D-2-13.5	Fuel Level Gauge	7	27000	1/8" Diesel Return Hose
4	5406-8-4	1/2" x 1/4" Reducer Bushing	8	5/16-P2	5/16" Red Diesel Hose
			9	FTA-DT-14.49	Standpipe, Brass

Lights & Brake System - 500 Gal. Generator Trailer

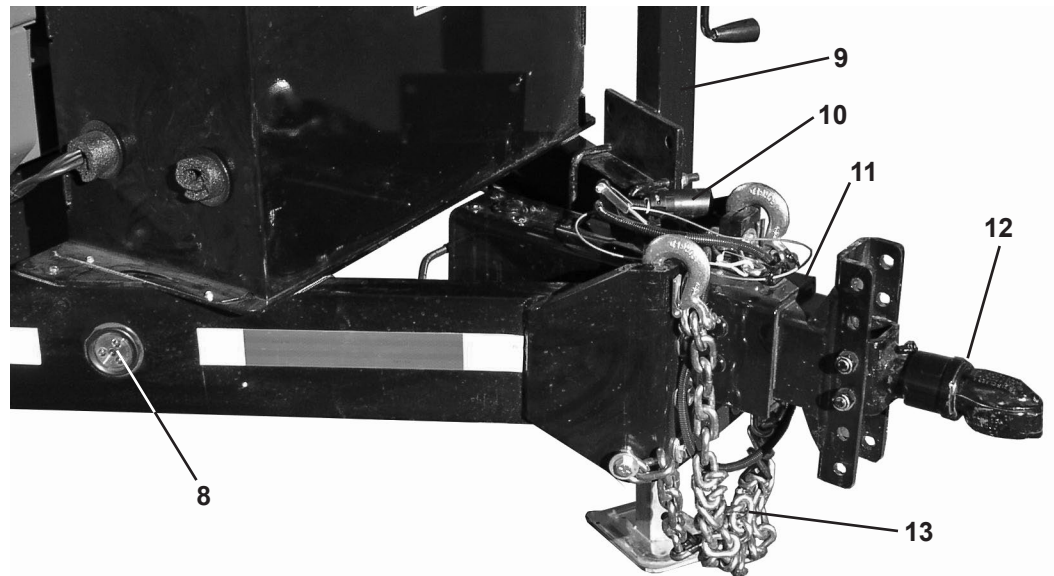
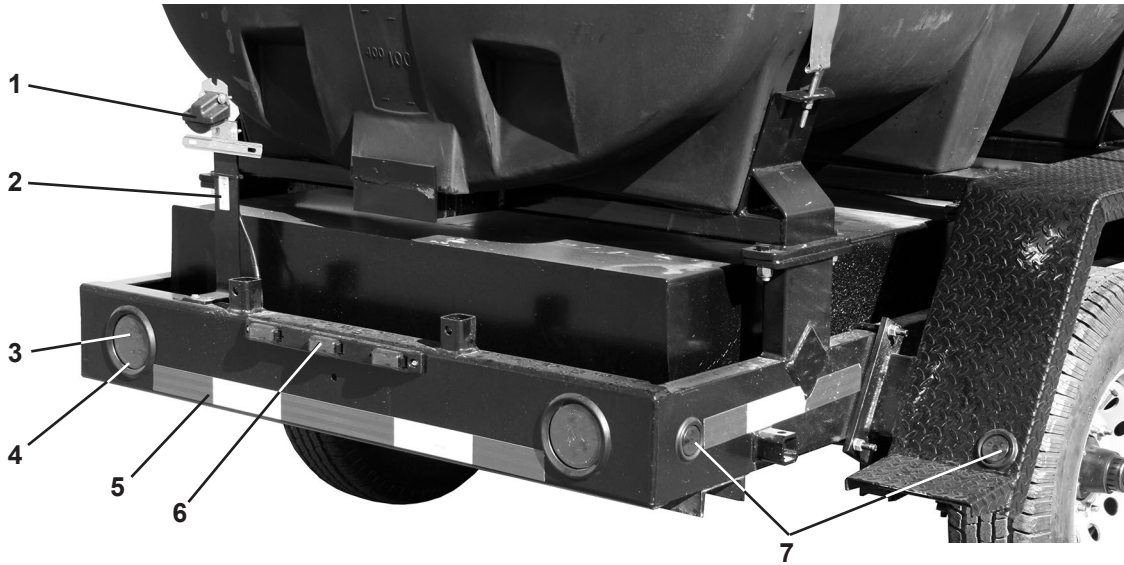

No.	Part No.	Description	No.	Part No.	Description
1	223210	License Plate Light Assembly	7	R203K	2" Red LED Light
2	W144007	License Plate Bracket	8	A203K	2" Amber LED Light
3	J-45-RK	4" LED Stop, Tail, Turn Light	9	W144006	Trailer Jack
4	95227	4" Round Grommet	10	5077003	7 Pole Connector Plug
5	TMP-3M-980-02	White/Red Reflective Tape	11	W121121	20,000 lb Surge Brake Actuator
6	CPL26R-3 BAR	LED 17" ID Lightbar	12	W-028657	15K Channel Coupler, 2 5/16"
			13	SC70-49	Safety Chain Kit



Tires & Axles

**Tire & Axles -- 500 Gal. Combo Trailer
1,025 Gal. Water Distribution Trailer
500 Gal. Generator Trailer**

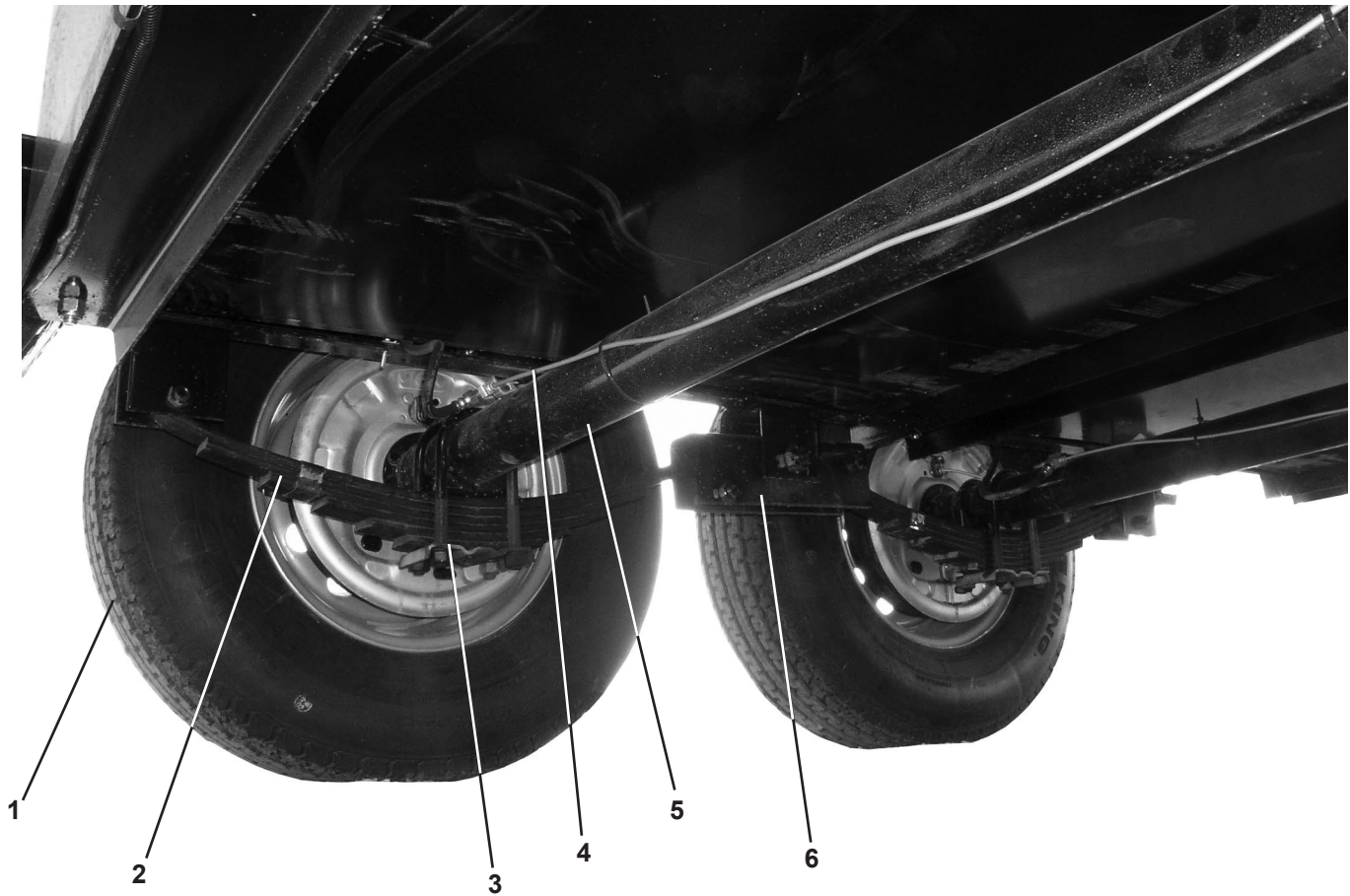

No.	Part No.	Description
1	660865831314115	3,520# Wheel/Tire Assembly ST235-80R16
2	4361-40	Slipper Spring, 2" 4K, 6 Leaf
3	4201	3" U-Bolt Kit
4	4781	Tandem Axle Hydraulic Line Kit
5	TS70705525865FBC	7K Brake Axle, Accu-Lube
6	4114-H	Hanger Kit

7,000 lb Axle Assemblies

TS70705525865FBC -- Axle Assembly

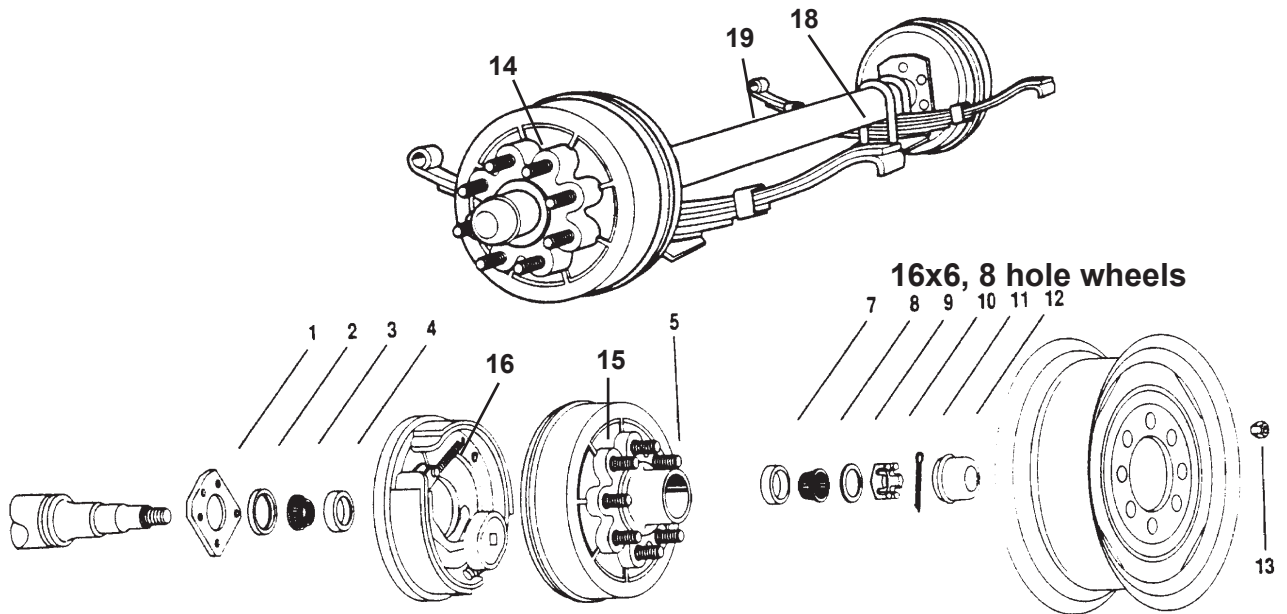

No.	Part No.	Description	No.	Part No.	Description
1	4-6T	Brake Flange	13	4756	Lug Nut
2	22333TBN	Grease Seal, double lip	14	92865A	Complete Brake Hub Ass'y.
3	25580	Inner Cone, 1.75 ID	15	92865A-1	Brake Hub, Bearings, Studs
4	25520	Inner Cup, 3.625" OD	16	4704-L	LH Electric Brake Ass'y, 12"x2¼"
5	4759-25-Z	Wheel Stud, ½" - 20x2.5"		4704-R	RH Electric Brake Ass'y, 12"x2¼"
7	14276	Outer Cup, 2.717" OD	17	4113-H	Triple Axle Slipper Spring Hanger Bracket (NS)
8	14125A	Outer Cone, 1.25" ID		4114-H	Tandem Axle Slipper Spring Hanger Bracket (NS)
9	4753	Spindle Washer, 1"	18	4201	3" U-Bolt Kit (1 per axle)
10	4754	Spindle Nut, 1" -14	19	4361-40	Slipper Leaf Springs, 2", 4K, 6 Leaf
11	4755	Cotter Pin, 1/8" x 2"		W120510	Equalizer Bar (Not Shown)
12	1605	Grease Cap			

**Wiring Schematic -- 500 Gal. Combo Trailer
1,025 Gal. Water Distribution Trailer
500 Gal. Generator Trailer**

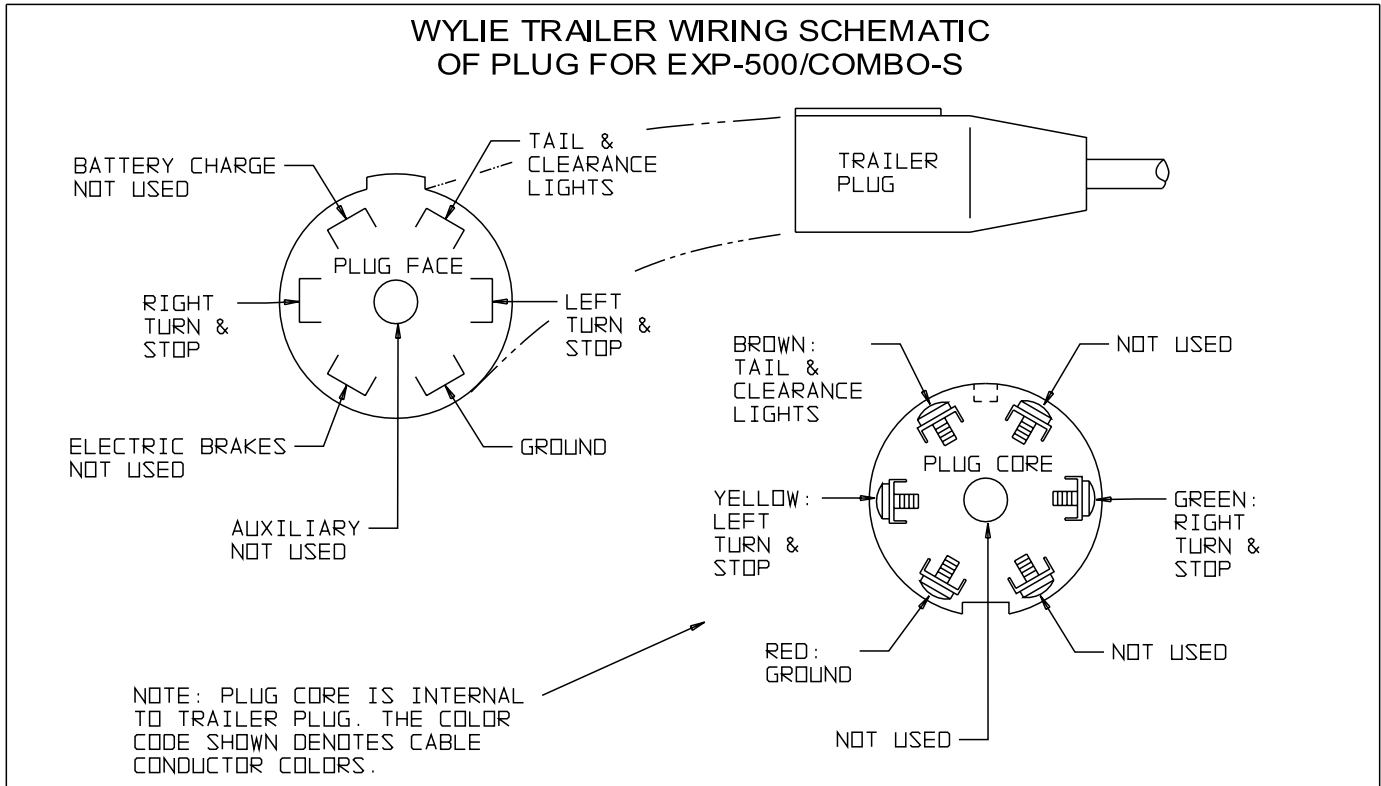

2015 – Wylie Manufacturing Company
Specifications Subject To Change Without Notice