

MANUAL TILTER 300

MODEL: MT21216LDC3S

This compact manual tilter boasts some of WPG's mightiest features and is CE compliant!

Intelli-Grip[®] Technology

This WPG-exclusive technology oversees power and vacuum systems, increasing productivity and improving safety.

Dual Vacuum System

Handles loads with the added safeguard of two independent air-line circuits.

2-Pad Design

Enables an operator to lift and tilt up to 300 lbs [135 kg].

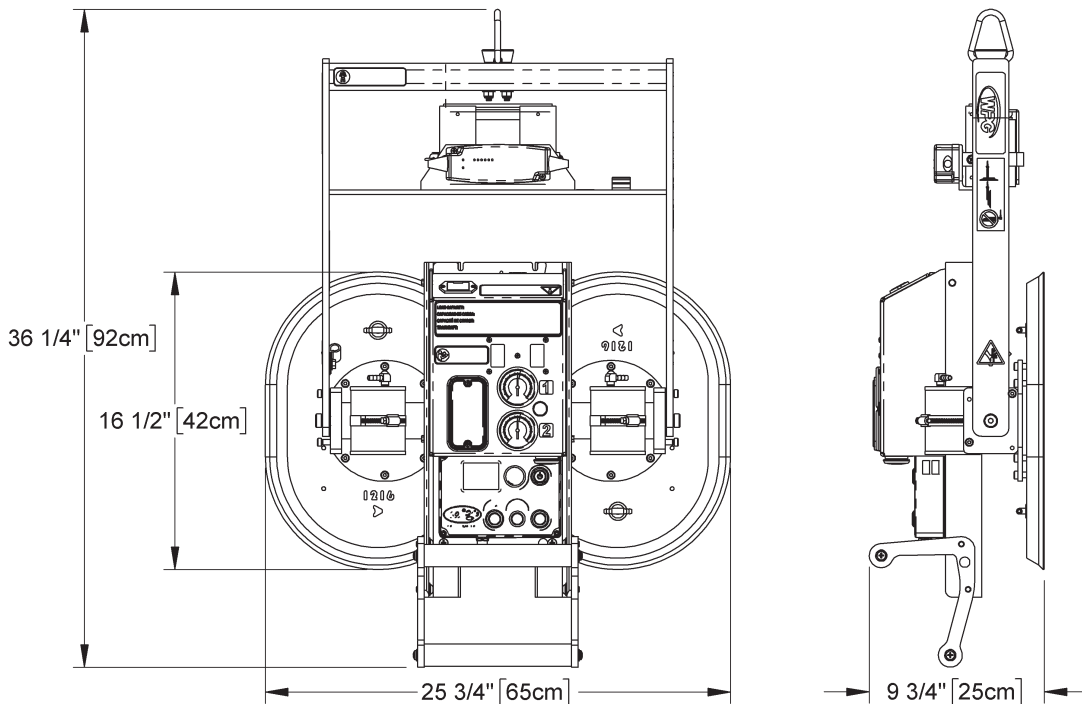

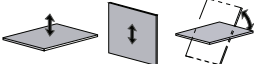
Model	MT21216LDC3S	
Maximum Load Capacity	300 lbs [135 kg]	
Standard Pad Spread	16-1/2" x 25-3/4" [42 cm x 65 cm]	
Number/Size of Pads	2 / 12" x 16" [30 cm x 41 cm] Oval - Flat/Lipped	
Load Movement	Manual tilt, 90° between upright and flat	
Apply/ Release Times	4 seconds/ 2 seconds (approximately)	
Standard Operating Power	12 volts DC, 5.5 amps	
Lifter Weight	65 lbs [29 kg]	

STANDARD FEATURES

Intelli-Grip® Technology

Available exclusively from Powr-Grip®! Actively monitors power and vacuum systems to increase safety and productivity, using LCD-screen messages, diagnostic codes and other features

Dual Vacuum System

Features two independent air-line circuits to reduce risk of workplace accidents

Battery and Charger

Provide independent, rechargeable power source for cord-free lifter operation in any location; on-board charger features status indicator and automatic shut-off

High-Flow Vacuum Pump

Enables a vacuum lifter to attach and release more rapidly, increasing productivity on the job

Battery Gauge

Shows energy level in real time, to help determine when charging is needed

Notification Buzzer and Strobe Light

Alert operator of problems with power or vacuum system, with various patterns of sound and light to indicate severity; back-up battery provides independent power for buzzer

Vacuum Gauges

Feature green and red zones, to clearly indicate whether vacuum level is sufficient for lifting

Vacuum Line Filters

Protect the vacuum generating system from contaminants

Vacuum Reserve Tanks

Increase battery run-time by reducing pump cycles needed to maintain vacuum

Green Lift Light

Provides visual assurance to know when vacuum is sufficient for lifting

Two-Action, Blow-Off Release

Uses two separate buttons to avoid accidental release, and reverses airflow to quickly release loads without after-stick

AVAILABLE OPTIONS

Air (Venturi) Power System (MT2HV11AIRS)

Enables lifter to operate using compressed air supply already available in many production facilities (Specifications may not be as listed. Please contact us for more information.)

Custom Pad Frame Sizes and Capacities

Accommodate customers' specific load weight and dimension requirements

DESIGN STANDARDS

ASME B30.20 (BTH-1 Design Category "B", Service Class "0"): Industry standards established by the American Society of Mechanical Engineers (ASME) and published by the American National Standards Institute (ANSI)

CE: Regulatory standards for health and safety required in the European Union

AS 4991: Regulatory standard required in Australia

Based on product information at time of publication. Environmental conditions can affect product performance and longevity; consult the product instructions on WPG.com or contact a Technical Sales Representative for more information.