



P1 CHANNEL LIFTER ORIGINAL EDITION

MODELS: P11104DC, P110C04DC,
P110T04DCO

A full range of load motion and a long-lasting battery make this lifter indispensable for installing glass at the job site or handling glass in multiple shop locations.

Channel Design

Gives operators the combination of tilt/rotation capabilities and an agile frame for installation in tight spaces.

Light Weight

Makes it an economical choice for loads up to 700 lbs.

Multiple Pad Choices

Capable of handling a variety of materials with appropriate vacuum pads installed.

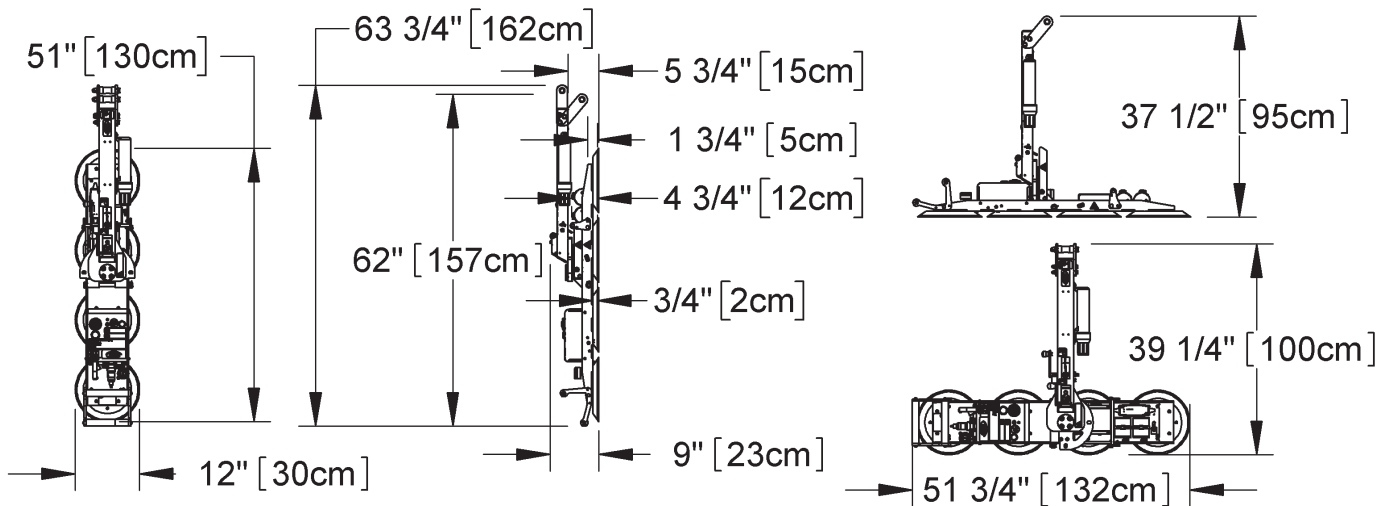

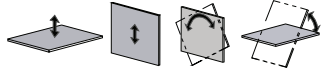
Models	P11104DC (For flat materials)	P110C04DC (For curved materials)	P110T04DCO (For textured materials)
Maximum Load Capacity	700 lbs [320 kg]	600 lbs [270 kg]	600 lbs [270 kg]
Standard Pad Spread	51" x 12" [130 cm x 30 cm]	49" x 10" [125 cm x 25 cm]	50¾" x 11¾" [129 cm x 30 cm]
Number/Size of Pads	4 / 11" [28 cm] diameter, lipped pads	4 / 10" [25 cm] dia. concave	4 / 10" [25 cm] dia. with replaceable sealing rings
Load Movement	Manual rotation, 180° edgewise, with locking at each 1/4 turn. Manual tilt, 90° between upright and flat, with automatic latching in upright position (in center rotation position, as shown on drawings). 		
Standard Operating Power	12 volts DC, 3.5 amps		
Lifter Weight	90 lbs [41 kg]		

STANDARD FEATURES

Adjustable-Position Lift Spool

Provides different lift points to optimize the lifter's hang angle, making repetitive material placement quicker and easier

Battery and Charger

Provide independent, rechargeable power source for cord-free lifter operation in any location; on-board charger features status indicator and automatic shut-off

Battery Gauge

Shows energy level in real time, to help determine when charging is needed

Low Vacuum Warning Light

Uses red light to warn operator when vacuum is not sufficient for lifting

Vacuum Gauge

Features green and red zones to clearly indicate whether vacuum levels are sufficient for lifting

Vacuum Line Filter

Prevent contaminants from damaging the vacuum generating system

Vacuum Reserve Tank

Increases battery run-time by reducing pump cycles needed to maintain vacuum

AVAILABLE OPTIONS

Dual Vacuum System (P1-04DC3)

Features two independent air-line circuits to reduce risk of workplace accidents

Air (Venturi) Power System (P1-04AIRS)

Enables lifter to operate using compressed air supply already available in many production facilities (Specifications may not be as listed. Please contact us for more information.)

Shipping Case (53005)

Provides protection for storing and shipping the lifter

Counterbalance Lifter (CB2DCS)

Adjusts the hang angle of the lifter or load as needed for each job, while also providing the ability to reach under eaves, gables and other overhanging obstacles; radio controls enable remote use

DESIGN STANDARDS

ASME B30.20 (BTH-1 Design Category "B", Service Class "0"): Industry standards established by the American Society of Mechanical Engineers (ASME) and published by the American National Standards Institute (ANSI)

AS 4991: Regulatory standard required in Australia

Channel Lifters are comprised of one or more Pad Channels and interchangeable Lift Frames for manually rotating and tilting materials. They may be ordered as complete units or as individual components to expand existing Channel Lifter systems. Lift Frames are available in single-channel or double-channel styles. Pad Channels can be switched from one frame to another in minutes.

COMPONENTS:

Pad Channels

Each channel features an independent, vacuum generating system, including vacuum pump, vacuum controls and standard features as listed on page 1.

PC1104DC: (for flat materials) 4 / 11" [28 cm] dia. lipped pads (94110, 94111, 94112)

PC10C04DCO: (for curved materials) 4 / 10" [25 cm] dia. concave pads (special order)

PC10T04DCO: (for textured materials) 4 / 10" [25 cm] dia. pads with replaceable sealing rings (special order)

Lift Frames

PCFT1A1: For one Pad Channel (94154)

PCFT2S35: For two Pad Channels, approx. 3½' [1.07 m] (94160)

PCFT2SA45: For two Pad Channels, approx. 4½' [1.38 m] pad spread (94165)

PCFT2SA7: For two Pad Channels, approx. 7' [2.14 m] pad spread (94170)

Interchangeable Arms

(Pad spread can be changed if optional arms are purchased)

FA235: Optional arms convert PCFT2SA7 or PCFT2S45 Lift Frames to PCFT2SA35 Lift Frame (57221AM)

FA245: Optional arms convert PCFT2SA7 or PCFT235 Lift Frame to PCFT2SA45 Lift Frame (57222AM)

FA27: Optional arms convert PCFT2SA45 or PCFT235 Lift Frame to PCFT2SA7 Lift Frame (57223AM)

SHIPPING CASE FOR P1 VACUUM LIFTER

Specially designed case protects your lifter during shipping and storage.

- Thermo-formed polymer makes case durable and water-resistant.
- Interior straps hold lifter firmly in place.
- Exterior straps keep case securely closed.
- Built-in handles facilitate manual handling.
- Case design enables stacking and forklift handling.



