

LCD Display S-886

User Manual V.2018

(for electric scooter only)



1. Exterior Parameters

Casing Material: ABS

Display Material: High Hardness Acrylic (the same hardness value as tempered glass).

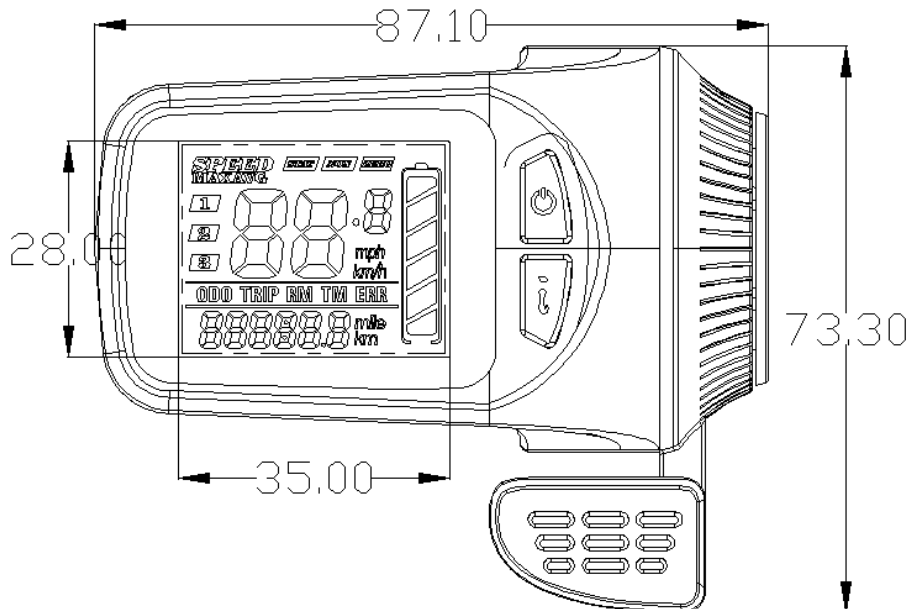

Front View

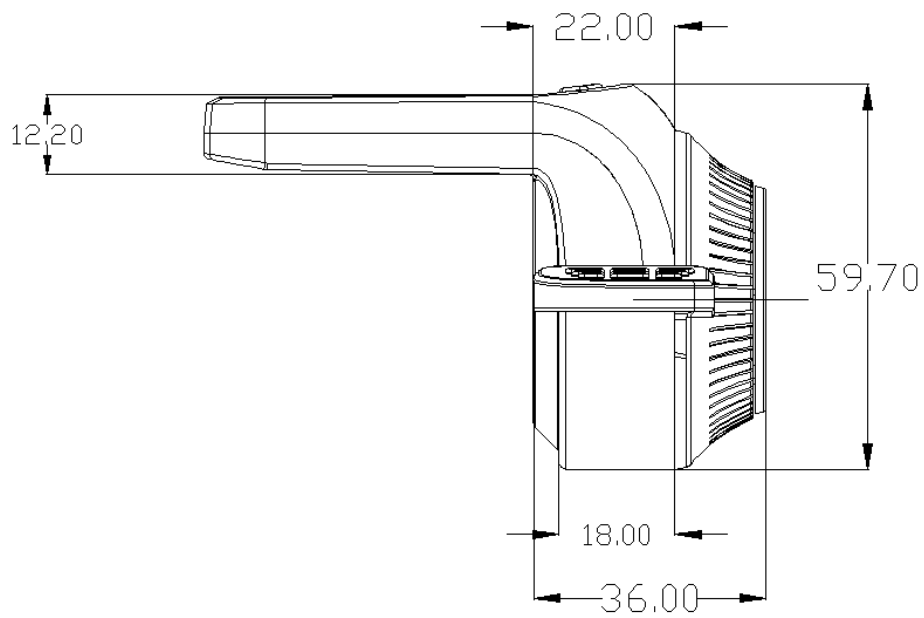

Side View

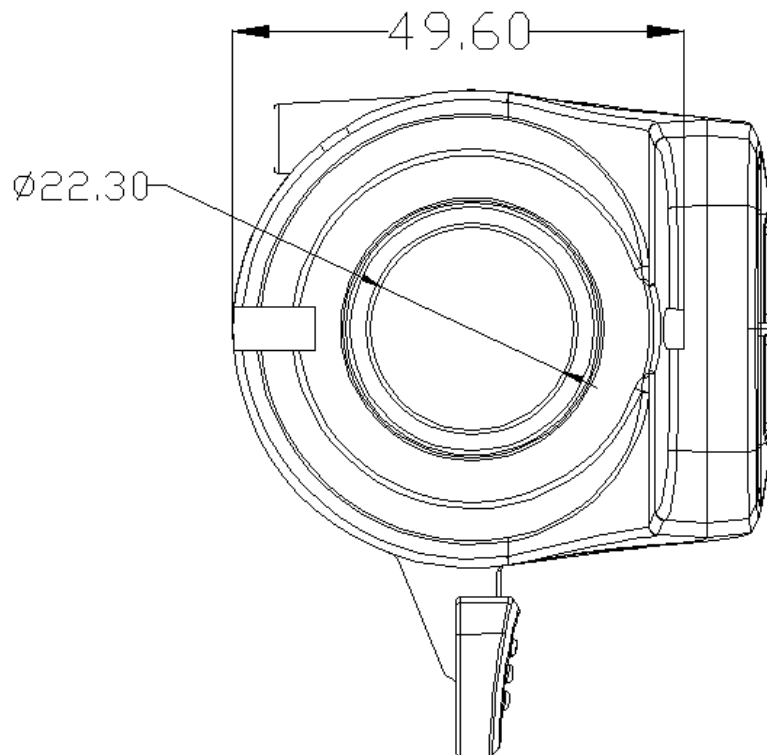

Thumb Throttle

2. Operating Voltage and Connections

a. **Operating Voltage:** DC24V / 36V Compatible, 36/48V Compatible (set by the control Display). Other operating voltage can be customized.

b. **Connections:**

Standard connector sequence

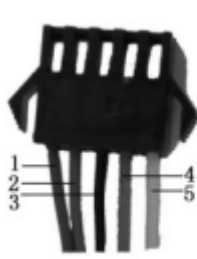

Controller Connector



Display End (Waterproof)



Controller End (Waterproof)

Standard Connector Sequence Table

Sequence No.	Wire Colour	Functions
1	Red (VCC)	Display Power Cord
2	Blue (K)	Controller Power Cord
3	Black (GND)	Display Ground Wire
4	Green (RX)	Display Data Receiving Wire
5	Yellow (TX)	Display Data Sending Wire

Note: Some products come with waterproof connectors, whose internal wire colors cannot be decided from outside.

3. Functions

a. Display

Speed Display, Battery Level Display, Error Indication, Total Mileage, Single Mileage

b. Control and Setting

Power Switch, Wheel Diameter Setting, Idleness Time Setting for Auto-Hibernation, Backlight Brightness Setting, Start Mode Setting, Drive Mode Setting, Voltage Level Setting, Controller Current Threshold Setting

c. Communications Protocol: UART

Display Readings (display at start for 1 second)

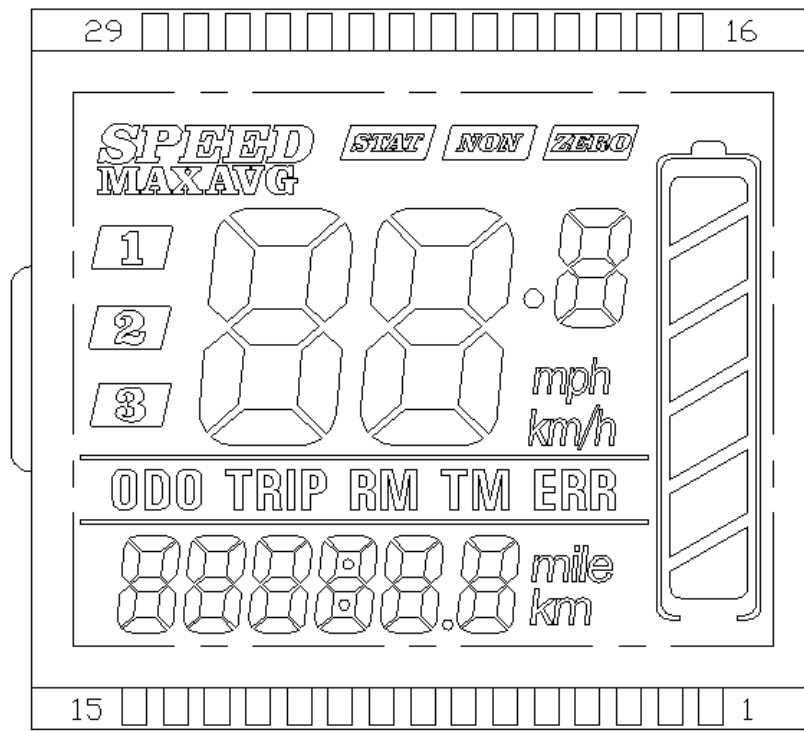

Interface Instruction



3.1 Battery Level

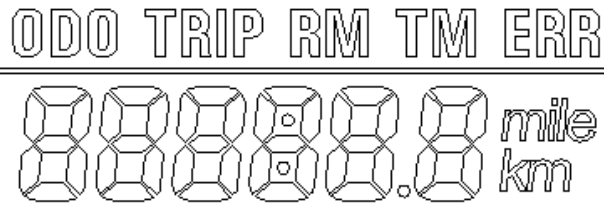

3.2 Multi-Function Display

- Total Mileage: ODO (km or mile)
- Single Mileage: TRIP
- Rest Mileage: RM (software support of battery protection board needed)
- Operation Time: TM
- Error Code: ERR

3.3 Error Code

Error Code (decimal)	Indications	Note
0	Normal	
1	Reserved	

2	Brake	
3	PAS Sensor Failure (riding mark)	Not Realized
4	6km/h Cruise	
5	Real-Time Cruise	
6	Low Battery	
7	Motor Failure	
8	Throttle Failure	
9	Controller Failure	
10	Communications Receiving Failure	
11	Communications Sending Failure	
12	BMS Communications Failure	
13	Light Failure	

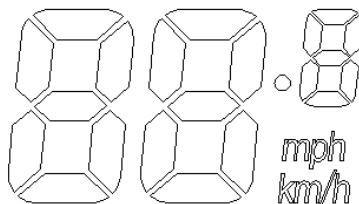

3.4 Speed Display

Measuring Unit: mph or km/h

The Display will calculate the actual travelling speed based on the wheel diameter and signal data (number of magnet steel is needed for motors with Hall sensors).



3.5 Power Assist Level

3.6 Direct Start and Kick-to-Start Mode

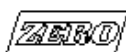
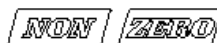

Direct Start

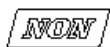

Kick-to-Start

4. Settings

P01: Backlight Brightness (1: darkest; 3: brightest)

P02: Mileage Unit (0: km; 1: mile)

P03: Voltage Class: 24V /36V (default) / 48V

P04: Hibernation Time (0: never, other figures refer to the hibernation time)

Unit: minute

P05: Power Gear – 0-3 Gears Mode

P06: Wheel Diameter Unit: inch Precision: 0.1

P07: Magnet Steel Number for Speed Test Range: 1-255

P08: Speed Limit

Range: 0-50km/h, parameter 50 indicates no speed limit.

1. Non-communications status (Display-controlled)

When the current speed exceeds the speed limit, the PWM output will be shut down; when the current speed falls to lower than the speed limit, the PWM output will be activated and the driving speed will be set as the current speed ± 1 km/h (only applies to assist power speed, not applicable to the handlebar speed).

2. Communications status (controller-controlled)

The driving speed will be kept constant as the limited value.

Error Value: ± 1 km/h (applicable to both the assist power/handlebar speed)

Note: The above-mentioned values are measured by metric unit (kilometers). When the measuring unit is switched to imperial unit (mile), the speed value displayed on the Display will be automatically switched to corresponding imperial unit, however the speed limit value in the imperial unit interface won't change accordingly.

P09: Direct Start / Kick-to-Start Setting:

0: Direct Start

1: Kick-to-Start

P10: Drive Mode Setting

0: Power Assist Drive Only– The specific gear of the assist drive decides the assist power value. In this status the handlebar does not work.

1: Electric Drive (Throttle) Only – The vehicle is driven by the handlebar. In this status the power gear does not work.

2: Power Assist + Electric Drive – Electric drive does not work in direct start mode.

P12: Assist Power Intensity Range: 0-5

P13: Power Magnet Steel Number: 5 / 8 / 12pcs

P14: Current Limit Value: 12A by default; Range: 1-20A

P15: Unspecified

P16: ODO Zero-Out: Long press the upper key for 5 seconds to zero out ODO.

5. Keys

Introduction of Keys









1. When the display is off, long press  to turn it on. When the display is



on, short press  to switch among ODO / TRIP / TM mode.





2. When the display is on, long press  to turn it off, or short press  to adjust power assist level.



3. Long press  +  to enter the setting menu. At the setting interface, short press  to adjust parameters. Long press  to switch the value increase/decrease function of this key .

Change parameter value:

Short press  to change parameter value.

Short press  to increase or decrease the value.

Short press  to save the previous change and jump to the next setting.

Long press  +  to exit setting interface, or wait for 8 seconds to automatically save values.

4. The thumb lever is used to adjust motor speed. Turn the lever from top down, and the motor will accelerate, release the lever and it will rebound.

Note: Due to product upgrade, the product you purchased may be slightly different from the descriptions in this user manual, and this won't affect normal usage.