

## 01. Product Overview

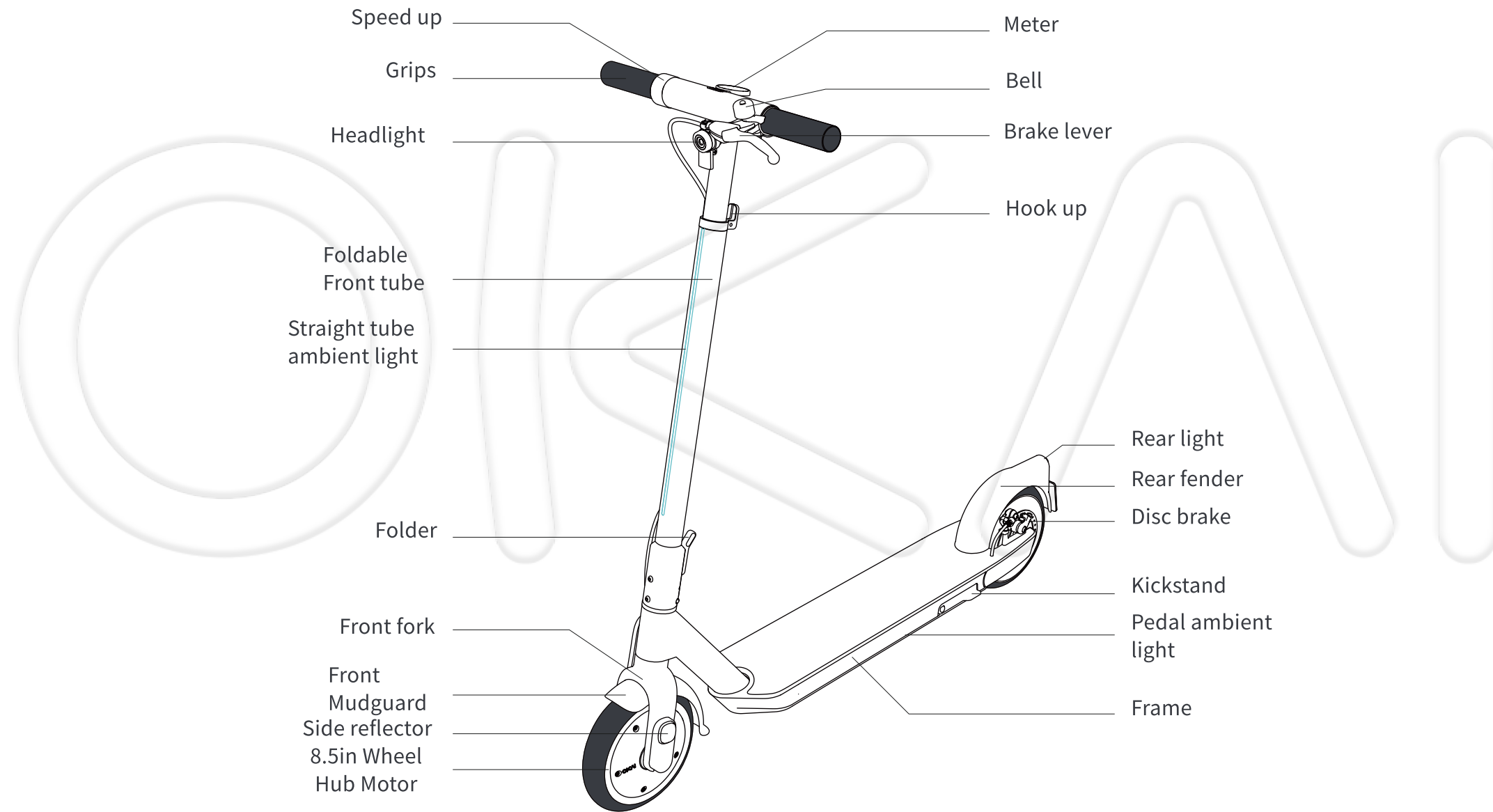

Size: length 1145\*width 450\*height 1130MM

## 02. App Download

- Search for **OKAI** in the App or Play Store and instal the app .
- Turn on your phone 's Bluetooth function then sign up or log into the app with your account .
- Connect to your board via the app . For help , visit our website or contact customer service .



### 03. Battery quantity

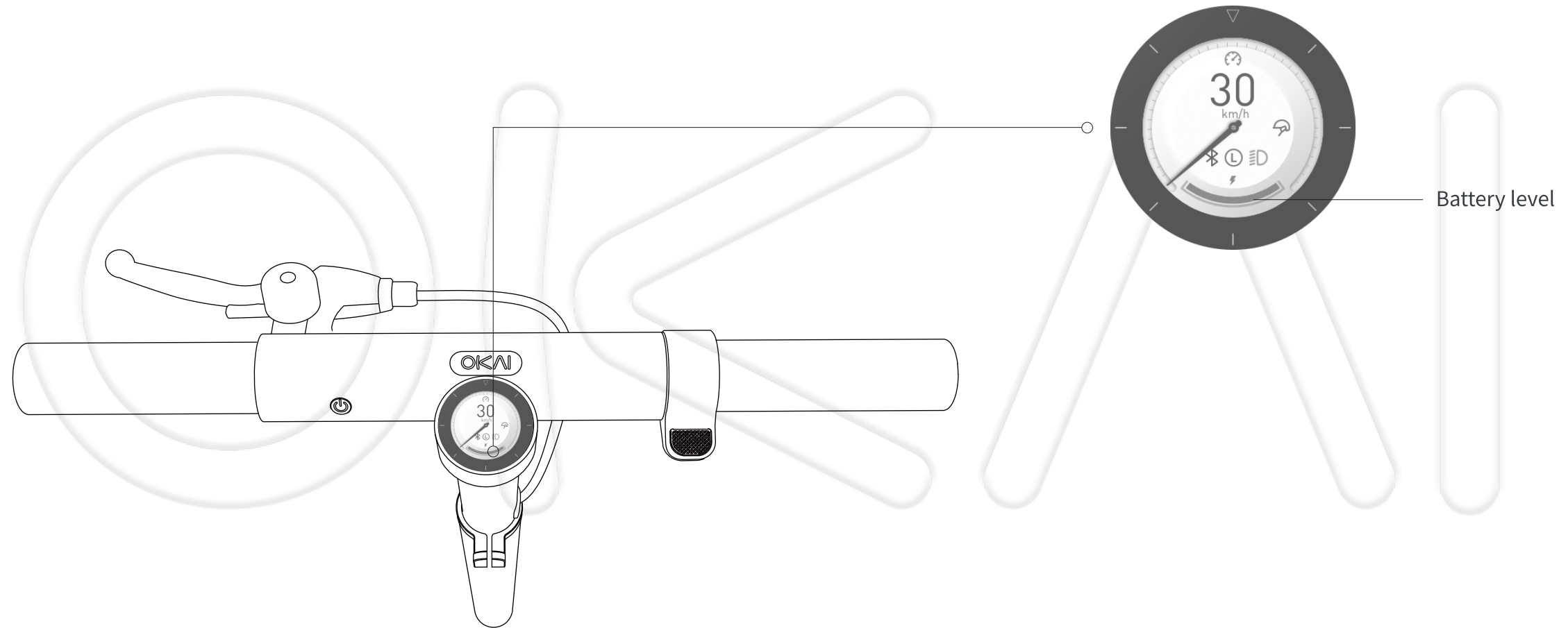

## 04. Charging

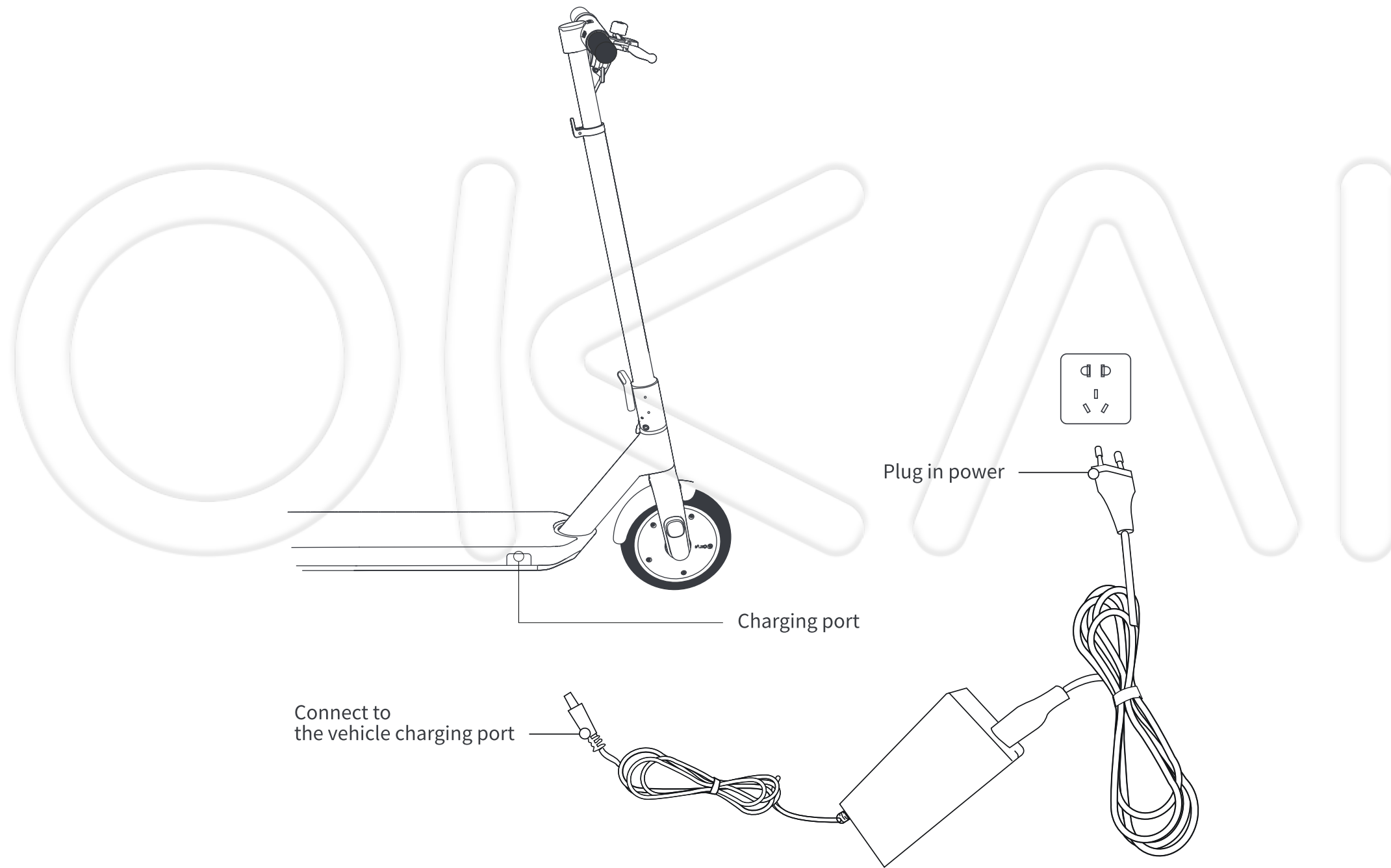

## 05. Brake system check and one-click folding

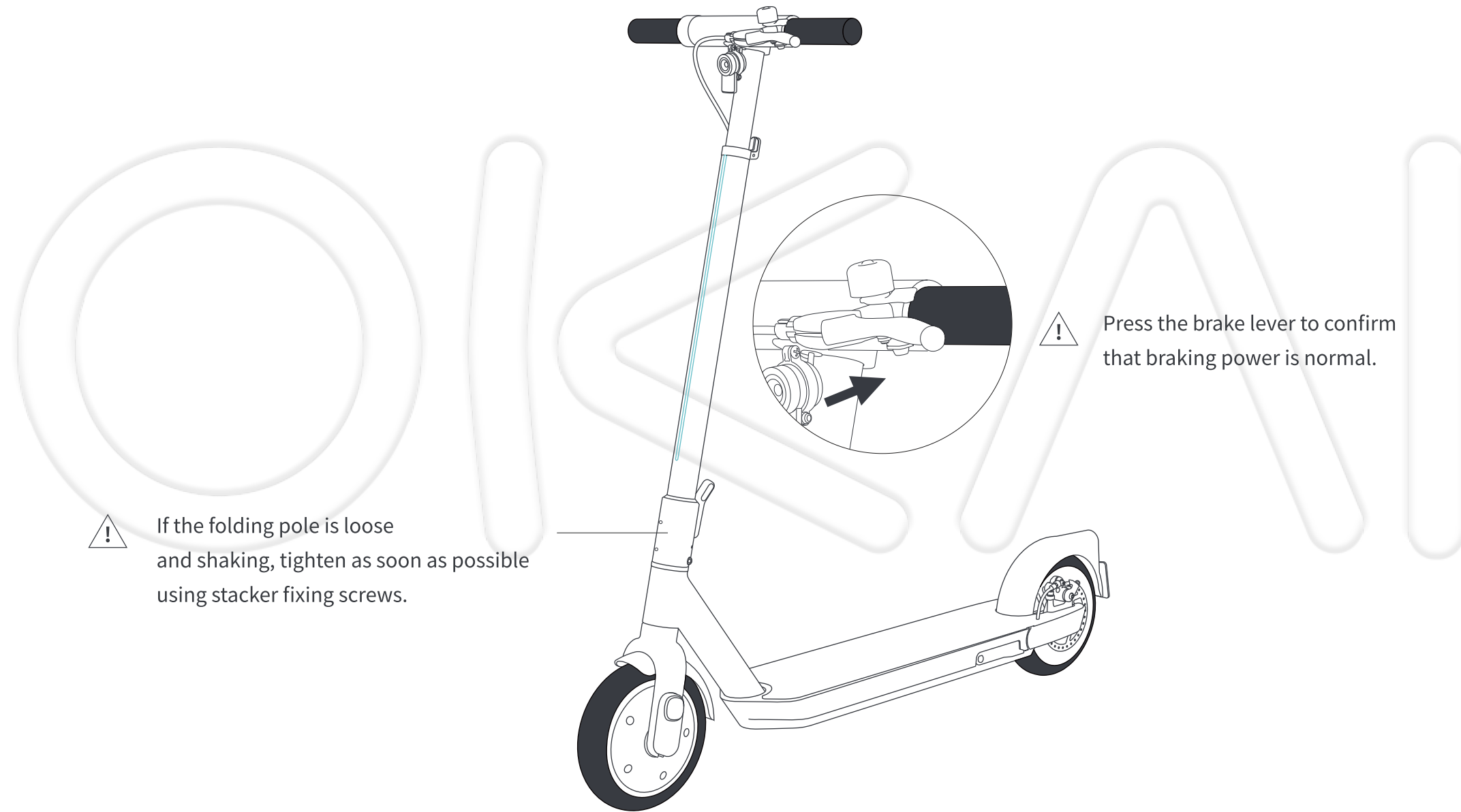

06. Wear protective equipments before ride

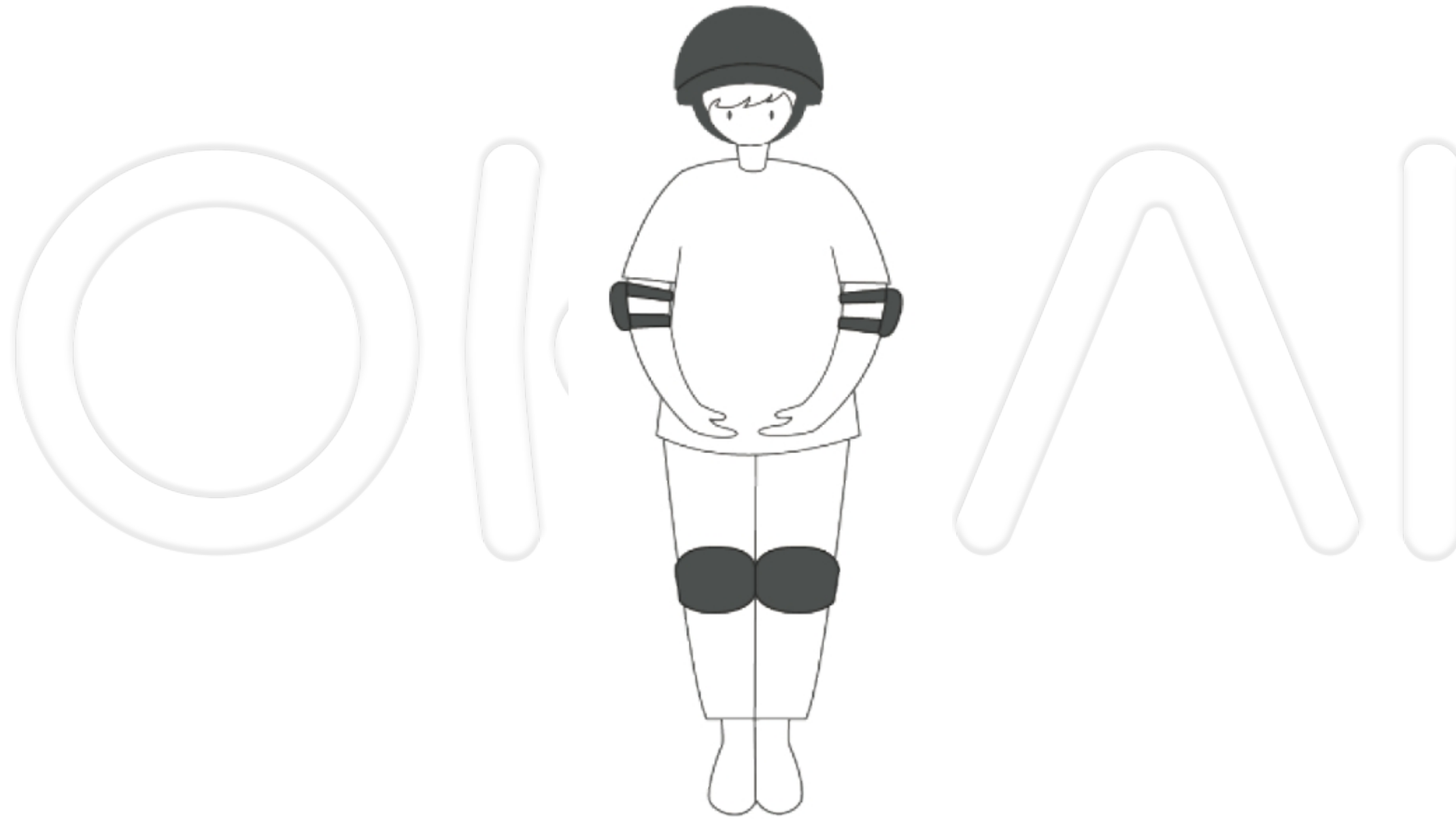

## 07. Non-zero start

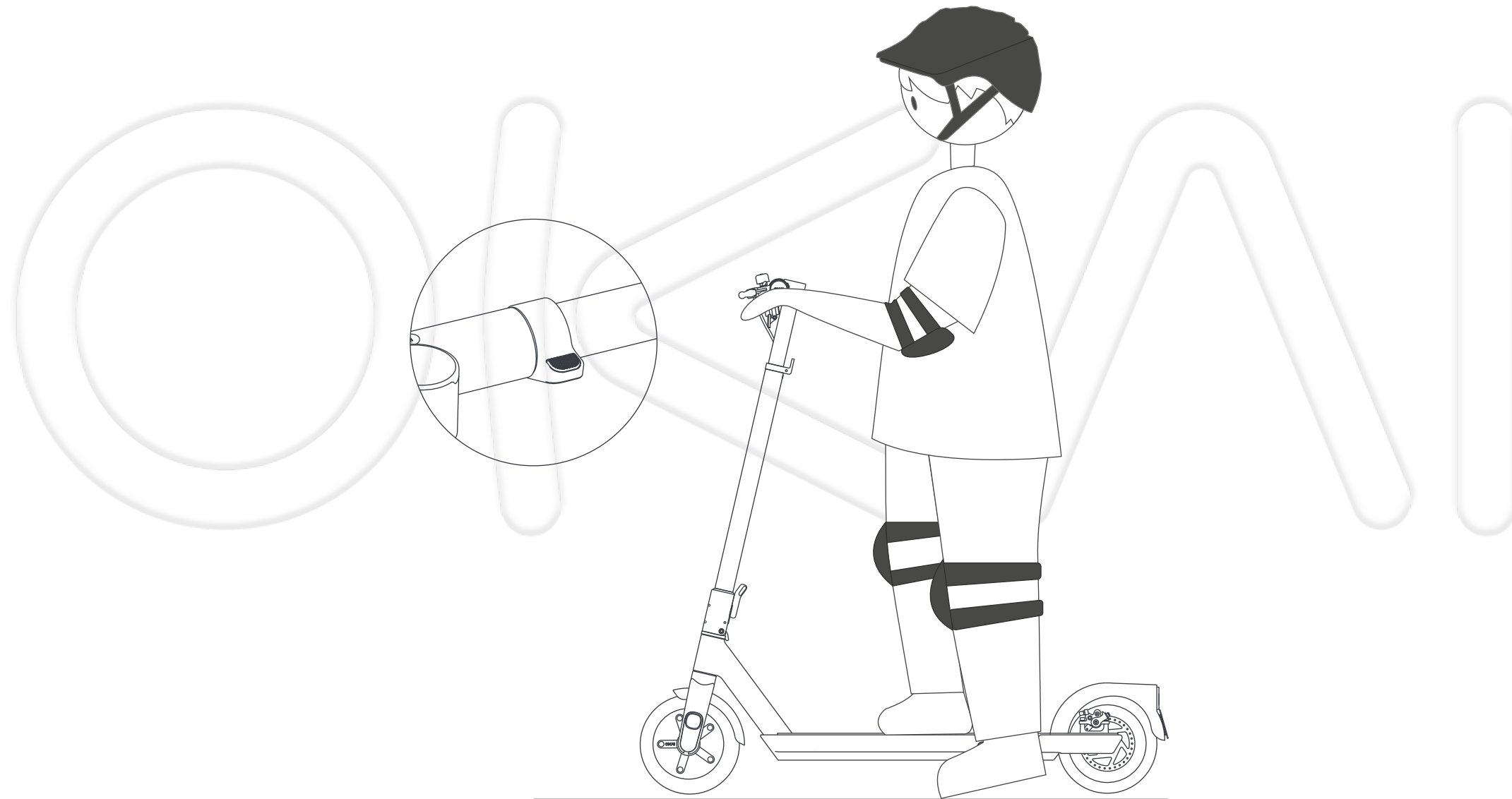

## 08. Acceleration and deceleration





## 09. Direction change

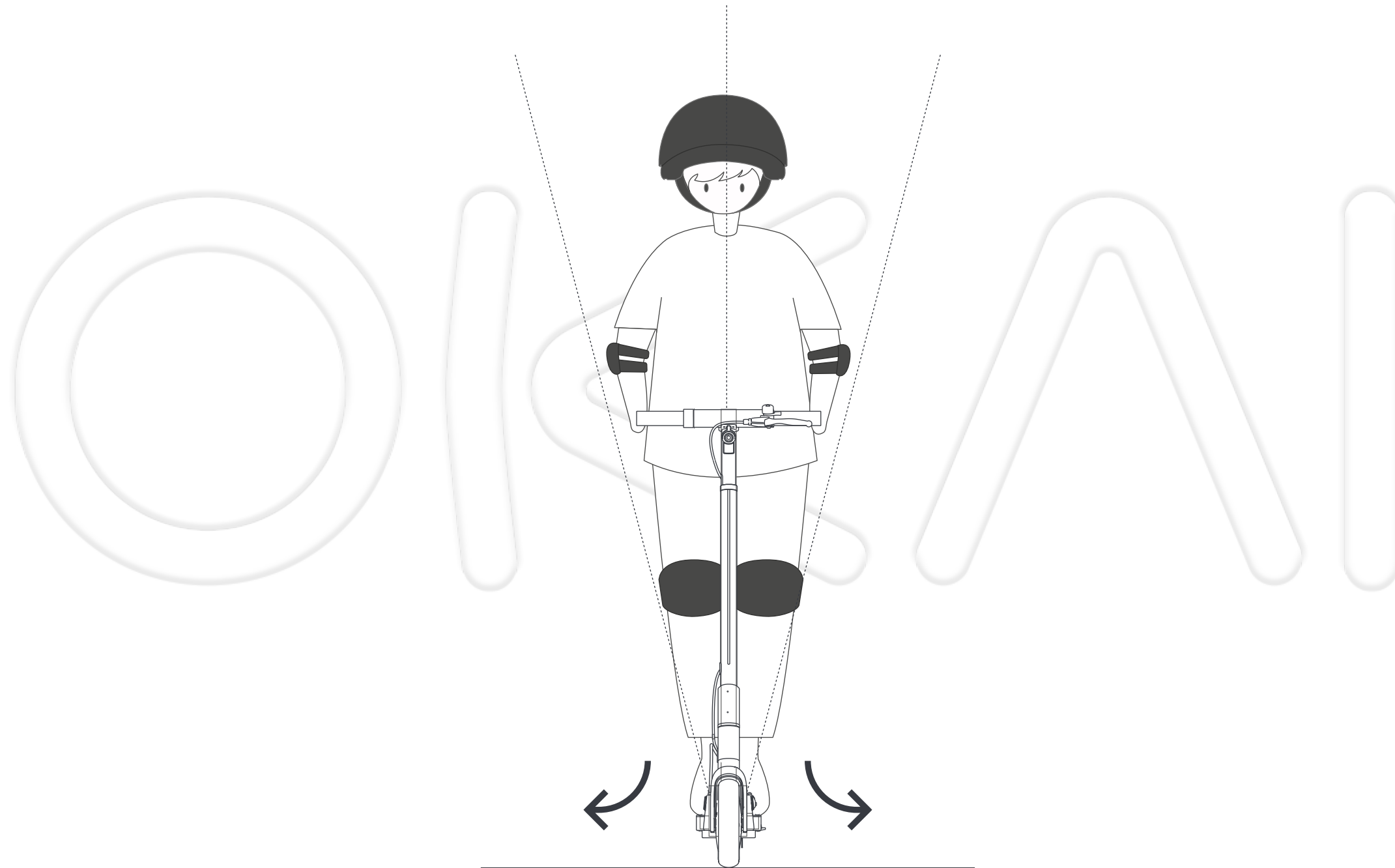

10. Stop

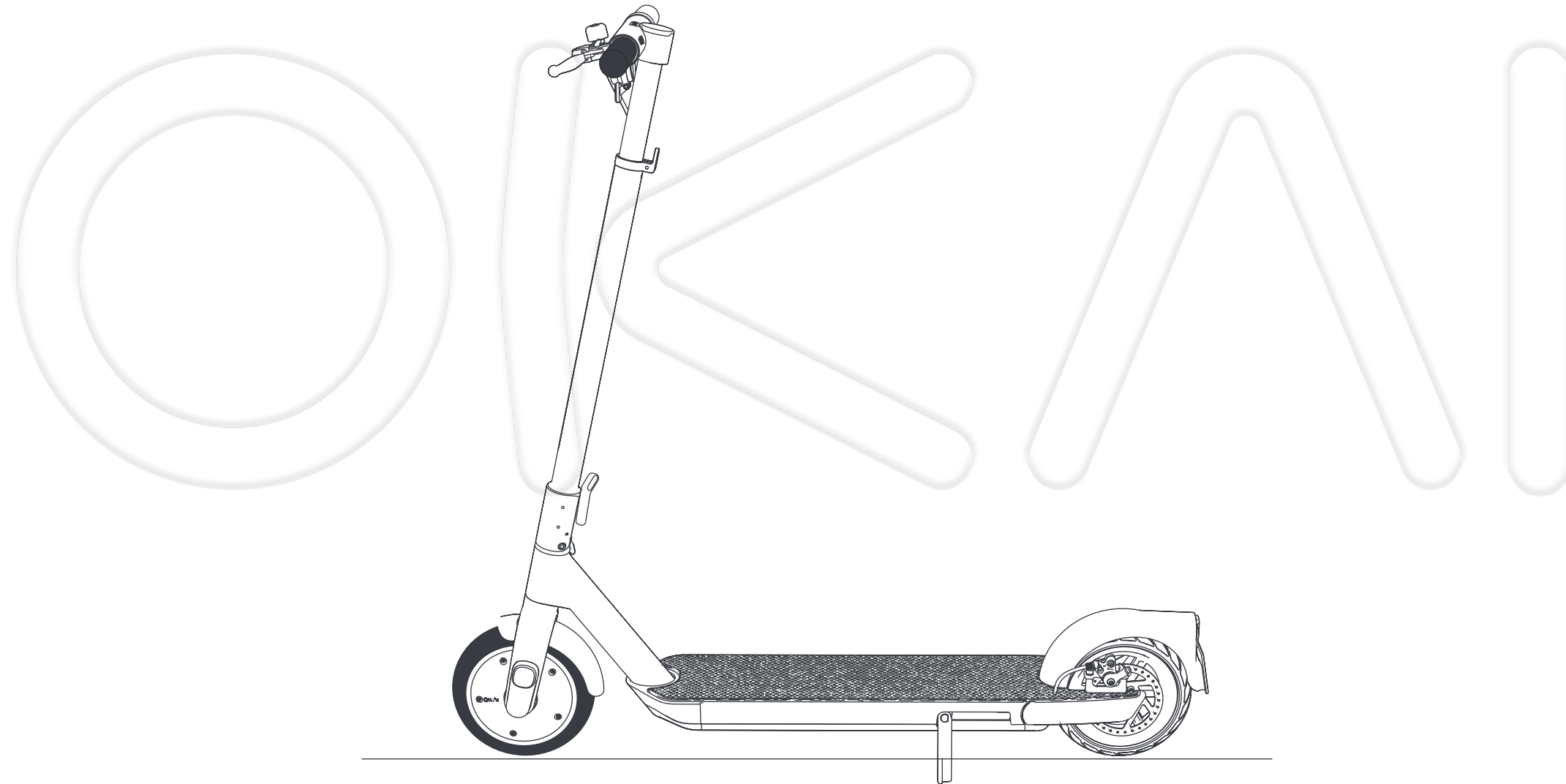

## 11. One-click folding operation

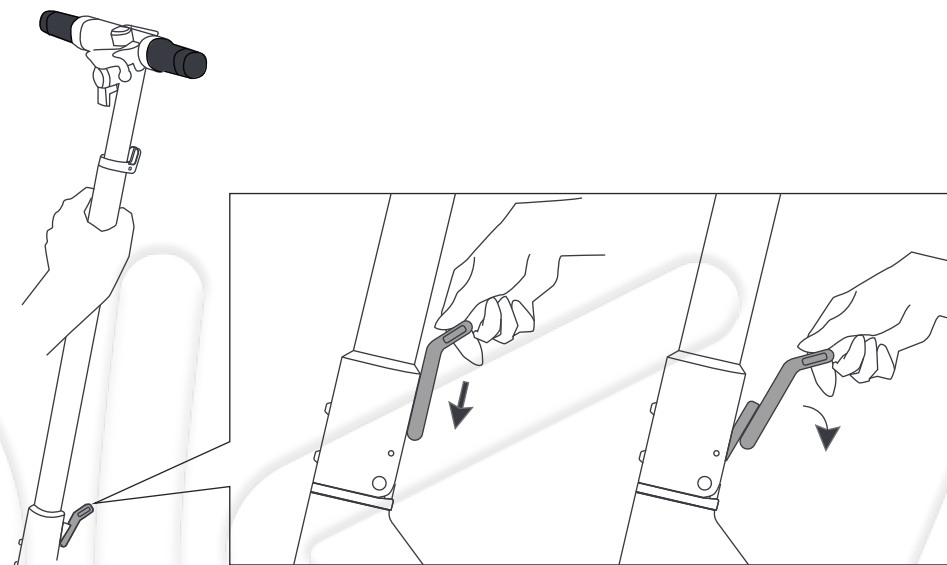

① Hold the front tube, press the folding handle down and then open it outwards;

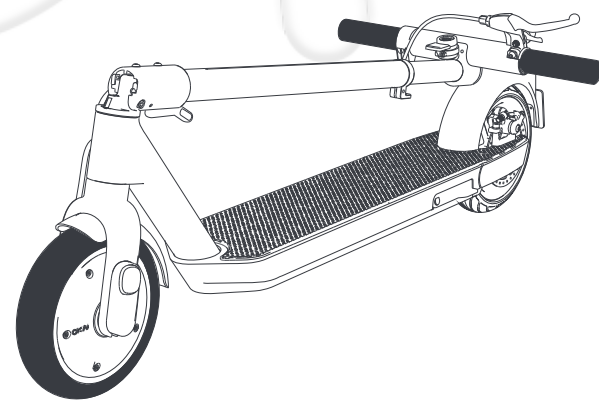

② Put down the front tube, the front tube is automatically locked;

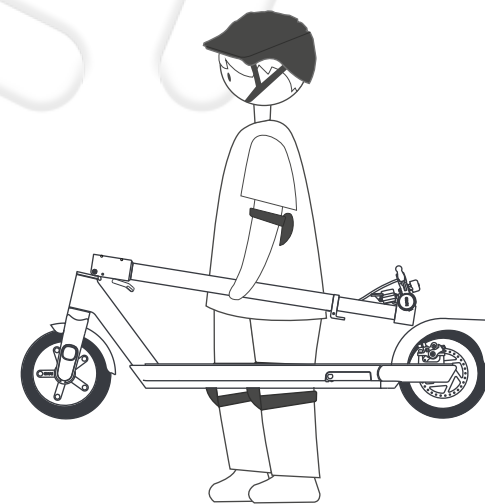

③ Hold the front tube to lift the electric scooter.

## 12. Product parameters

Item	Content	ES20
Specifications	Dimensions(Unfolding):length,width,height	1145*450*1130(mm)
	Dimensions(folding):length,width,height	1145*450*400(mm)
	N.W.	16KG
	Maximum Speed	25km/h
	*Range	40Km
	Maximum Gradient	20%
	Adapted Terrain	Flat /Mountain
	Operating Temperature	0~40°C
	Storage Temperature	-20~45°C
	IP Rating	Finished product IPX5
	Charging Time	2A<6