

blair



<i>Contents</i>	<i>Page no.</i>
TR7003WN SpeedQueen Washer	3
TC5003WN SpeedQueen Washer	3
DR7003WE SpeedQueen Dryer	4-5
DC5003WG SpeedQueen Dryer	6

Harway Appliances

harwayappliances.com

Jeff Jenkins

5124917600

Search **20220504170810035SC**

Version 1.1

Wed, May 4, 2022

12:08 PM CDT



enterprise.steelcod.com/sp/harw/QASMLLNA

Note about page numbers:

Because the original manufacturer's documents are not altered in any way, the page numbers displayed on the page may not correspond to the page number within this package.

All specifications are intended for initial planning purposes only.

Manufacturers reserve the right to change specifications at any time without notice. Always consult the installation instructions found on the manufacturer's website or included with the appliances before installation.

TOP LOAD WASHERS

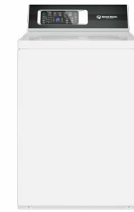
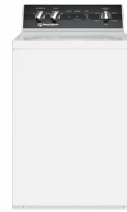
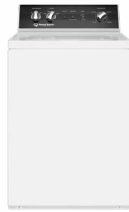

TR3

TR5

TR7

TC5

Product Code	TR3003WN	TR5003WN	TR7003WN	TC5003WN
Available Colors	White	White	White	White
Capacity – Cu. Ft.	3.2	3.2	3.2	3.2
Stainless Steel Wash Tub	•	•	•	•
Porcelain Outer Tub	•	•	•	•
Preset Cycles	4	6	8	6
Preset Special Cycles			8	
Variable Speed, 1 HP Motor	•	•	•	
Two-Speed, ½ HP Motor				•
Automatic Balancing System	•	•	•	•
Agitator	•	•	•	•
Durable 3 - Coat Finish	•	•	•	•
Prewash			•	
Load Size Selections	3	3	4	2
Temperature Selections	3	4	4	4
Soil Level Selections	2	2	4	2
Time Remaining Display			•	
End-of-Cycle Signal	•	•	•	•
Favorite Cycles			•	
Speed Cycle			•	
Delay Start			•	
Warranty	3-Year Parts & Labor	5-Year Parts & Labor	7-Year Parts & Labor	5-Year Parts & Labor
Model No.	AWN43RSN116TW01	AWN63RSN116TW01	AWNE9RSN116TW01	AWN632SP116TW02

Agency approvals: cULus

For the most accurate information, the installation guide should be used for all design and construction purposes. Due to continuous product improvements, design and specifications are subject to change without notice. The quality management systems of Alliance Laundry Systems are registered to ISO 9001.

Dimensions	W-Width	H-Height	D-Depth	Height with Lid Open
TR3003WN	25 5/8"	42 3/4"	28"	53"
TR5003WN	25 5/8"	42 3/4"	28"	53"
TR7003WN	25 5/8"	42 3/4"	28"	53"
TC5003WN	25 5/8"	42 3/4"	28"	53"

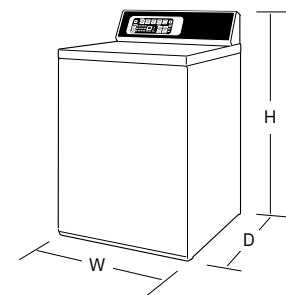

Optional Accessories

Drain Extension Kit – Part No: 204512

Hose Kit – Part No: 807239

Siphon Break Kit – Part No: 562P3

Dimensions

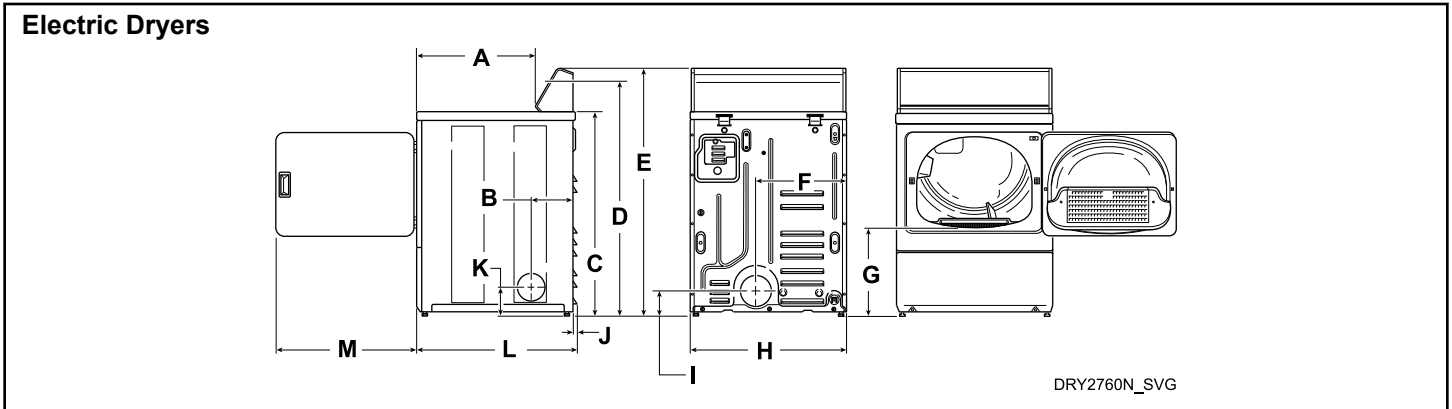

A	22.38 in. [569 mm]
B	8.0 in. [203 mm]
C	* 36 in. [914 mm]
D (to controls)	Electronic Control: *41.25 in. [1048 mm] Knob Control: *40.75 [1035 mm]
E	* 42.75 in. [1086 mm]
F	15.4 in. [391 mm]
G	* 15.44 in. [392 mm]
H	26.875 in. [683 mm]
I	* 4.0 in. [102 mm]
J	0.4 in. [11 mm]
K	* 4.5 in. [114 mm]
L	28 in. [711 mm]
M	23.5 in. [597 mm]
NOTE: Exhaust openings are 4 inch [102 mm] metal ducting.	* With leveling legs turned into base.

DRYERS



DR7

DR5

DR3

DC5

Product Code	Gas:	DR7003WG	DR5003WG	DR3003WG	DC5003WG
	Electric:	DR7003WE	DR5003WE	DR3003WE	DC5003WE
Capacity – Cu. Ft.		7.0	7.0	7.0	7.0
Galvanized Cylinder		•	•	•	•
ADA Compliant		•	•	•	•
Cylinder Light		•	•	•	•
Reversible Door		•	•	•	•
Lint Filter Guard		•	•	•	•
Sanitize		•	•	•	•
Preset Cycles		10	9	3	4
Temperature Selections		4	5	3	4
End-of-Cycle Signal		•	•		•
Extended Tumble		•	•		•
Moisture Sensor		•	•		
Commercial Cool-Down Technology		•	•		
ENERGY STAR® Certified		•	•		
Steam Boost		•	•		
Steam Refresh		•	•		
Steam Sanitize		•			
Anti-Static		•			
Time Remaining Display		•			
Favorite Cycles		•			
Pet Plus™ Cycles		•			
Warranty		7-Year Parts & Labor	5-Year Parts & Labor	3-Year Parts & Labor	5-Year Parts & Labor
Model No. (Gas)		ADGE9RYS117TW01	ADG6HRY117TW01	ADG3SRGS117TW01	ADG4BRGS117TW01
(Electric)		ADEE9RYS177TW01	ADE6HRY177TW01	ADE3SRGS177TW01	ADE4BRGS177TW01

For the most accurate information, the installation guide should be used for all design and construction purposes. Due to continuous product improvements, design and specifications are subject to change without notice. The quality management systems of Alliance Laundry Systems are registered to ISO 9001.

Dimensions	W-Width	H-Height	D-Depth	WSH-Work Surface Height	Depth with Door Open
DR7003WG / DR7003WE	26 7/8"	42 3/4"	28"	36"	51 1/2"
DR5003WG / DR5003WE	26 7/8"	42 3/4"	28"	36"	51 1/2"
DR3003WG / DR3003WE	26 7/8"	42 3/4"	28"	36"	51 1/2"
DC5003WG / DC5003WE	26 7/8"	42 3/4"	28"	36"	51 1/2"

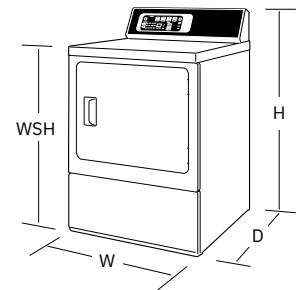

Optional Accessories

- Drying Rack – Part No: D512082
- Directional Exhaust Kit – Part No: 528P3
- Conversion Kit = Gas to LP – Part No: 649P3
- Flexible Metal Vent Kit – Part No: 521P3

Agency approvals: cULus, CSA us star, MA gas board

DRYERS



DR7

DR5

DR3

DC5

Product Code	Gas:	DR7003WG	DR5003WG	DR3003WG	DC5003WG
	Electric:	DR7003WE	DR5003WE	DR3003WE	DC5003WE
Capacity – Cu. Ft.		7.0	7.0	7.0	7.0
Galvanized Cylinder		•	•	•	•
ADA Compliant		•	•	•	•
Cylinder Light		•	•	•	•
Reversible Door		•	•	•	•
Lint Filter Guard		•	•	•	•
Sanitize		•	•	•	•
Preset Cycles		10	9	3	4
Temperature Selections		4	5	3	4
End-of-Cycle Signal		•	•		•
Extended Tumble		•	•		•
Moisture Sensor		•	•		
Commercial Cool-Down Technology		•	•		
ENERGY STAR® Certified		•	•		
Steam Boost		•	•		
Steam Refresh		•	•		
Steam Sanitize		•			
Anti-Static		•			
Time Remaining Display		•			
Favorite Cycles		•			
Pet Plus™ Cycles		•			
Warranty		7-Year Parts & Labor	5-Year Parts & Labor	3-Year Parts & Labor	5-Year Parts & Labor
Model No. (Gas)		ADGE9RYS117TW01	ADG6HRY117TW01	ADG3SRGS117TW01	ADG4BRGS117TW01
(Electric)		ADEE9RYS177TW01	ADE6HRY177TW01	ADE3SRGS177TW01	ADE4BRGS177TW01

For the most accurate information, the installation guide should be used for all design and construction purposes. Due to continuous product improvements, design and specifications are subject to change without notice. The quality management systems of Alliance Laundry Systems are registered to ISO 9001.

Dimensions	W-Width	H-Height	D-Depth	WSH-Work Surface Height	Depth with Door Open
DR7003WG / DR7003WE	26 7/8"	42 3/4"	28"	36"	51 1/2"
DR5003WG / DR5003WE	26 7/8"	42 3/4"	28"	36"	51 1/2"
DR3003WG / DR3003WE	26 7/8"	42 3/4"	28"	36"	51 1/2"
DC5003WG / DC5003WE	26 7/8"	42 3/4"	28"	36"	51 1/2"

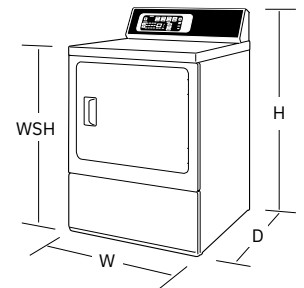

Optional Accessories

- Drying Rack – Part No: D512082
- Directional Exhaust Kit – Part No: 528P3
- Conversion Kit = Gas to LP – Part No: 649P3
- Flexible Metal Vent Kit – Part No: 521P3

Agency approvals: cULus, CSA us star, MA gas board