

STEEL YARD RAMP (SYR) & STEEL DOCK TO GROUND RAMP (SDG) Installation & Owner's Manual

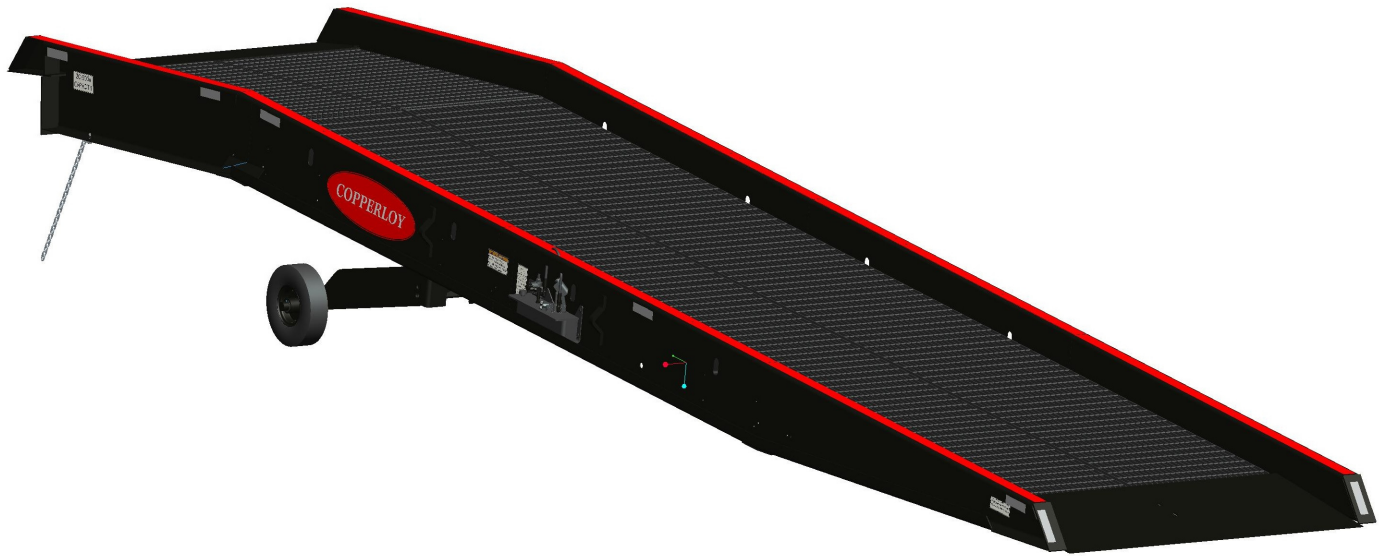

by
JH INDUSTRIES, INC.

1981 E. Aurora, Rd.
Twinsburg, Ohio 44087
(330) 963-4105 (Phone)
1-800-321-4968 (Toll Free)
www.copperloy.com

Model # _____
Serial # _____
Date: _____

Rev: 12/2016

WARNING

Do not install, operate or service this product unless you have read and understand the Safety Practices, Warnings, Installation and Operating Instructions contained in this manual before . Failure to do so could result in serious injury or death.



This page left blank intentionally



WARRANTY

ALL WARRANTY CLAIMS MUST HAVE PRE-APPROVED RATES, TIMES AND AUTHORIZATION NUMBERS PRIOR TO ANY FIELD WORK, IN ORDER TO BE ACCEPTED BY JH INDUSTRIES, INC.

J H Industries, Inc. expressly warrants that any STEEL YARD RAMP sold by it will be free from defects in material and workmanship under normal use for a period of five (5) years on all structural parts and one (1) year on all steel grating and hydraulic parts from the earlier of, 1) sixty (60) days after the date of shipment, or 2) the date of installation of the STEEL YARD RAMP by the original purchaser, provided the purchaser maintains and operates the STEEL YARD RAMP in accordance with the Owners Manual.

In the event that the STEEL YARD RAMP proves to be defective in materials or manufacturing workmanship within the applicable period, J H Industries, Inc. will, at its option:

1. Replace the STEEL YARD RAMP or the defective portion thereof without charge to the purchaser, or
2. Alter or repair the STEEL YARD RAMP, on site or elsewhere, without charge to the purchaser.

This warranty IS EXCLUSIVE AND IS IN LIEU OF ALL GUARANTEES AND WARRANTIES, EXPRESSED OR IMPLIED BY ANYONE OTHER THAN J H Industries, Inc. sole warranty obligation shall be as set forth above. JH Industries, Inc. reserves the right at any time and only with prior written notification to change or alter the warranties expressed and provided.

The warranty does not cover any failure caused by improper installation, abuse, misapplication, overloading, negligence, or failure to maintain the STEEL YARD RAMP properly. Parts requiring replacement due to damage resulting from vehicle impact, abuse, improper operation or lack of proper protection are not covered by this warranty. Seller assumes no responsibility or liability for (1) consequential damages of any kind which result from the use or misuse of the STEEL YARD RAMP; (2) damage or failure resulting from the use of unauthorized replacement parts or modification to the MOBILE YARD RAMP; (3) damage resulting from the misuse of the STEEL YARD RAMP. THERE ARE NO WARRANTIES, EXPRESSED OR IMPLIED, WHICH EXTEND BEYOND THE DESCRIPTION ABOVE. THERE IS NO WARRANTY OF MERCHANTABILITY OR OF FITNESS FOR A PARTICULAR PURPOSE.

J H Industries, Inc. warranties extend only to the product itself.

J H Industries, Inc. DISCLAIMS all liability arising out of the workmanship, methods and materials used by the installer.

J H Industries, Inc. DISCLAIMS all liability for premature wear, product failure, property damage or bodily injury arising from improper installation or maintenance.

WARRANTIES, whether expressed or implied, relating to workmanship and materials used in connection with the installation of J H Industries, Inc. products are specifically DISCLAIMED.

INTRODUCTION

Welcome, and thank you for purchasing your Steel Yard Ramp from Copperloy by JH Industries Inc. It is designed to give you many years of trouble-free operation.

This manual contains information that is needed to operate and maintain the ramp safely. It also contains a complete parts list and information about ordering replacement parts. Please read completely before using your new Steel Yard Ramp.

This manual also contains a complete parts list and information about ordering replacement parts. JH Industries, Inc. has selected components for best fit and function for each of our products, therefore replacement parts should be identical to original equipment or have written approval for non-original equipment. **JH Industries, Inc. will not be responsible for equipment failures due to incorrect or non-approved replacement parts.**

Verify that this is the most current Installation, Operation and Service Manuals.

To obtain an updated version please contact:

JH Industries Inc.

1981 E. Aurora Rd.

Twinsburg, Ohio 44087

(330) 963-4105 (Phone) or 1-800-321-4968 (toll free)

Or visit our website under Steel Container Ramps to download and print an up to date manual.

www.copperloy.com



TABLE OF CONTENTS

WARRANTY	1
INTRODUCTION	1
TABLE OF CONTENTS	2
SAFETY	2
SAFETY PRACTICES	3
RECOMMENDED UNLOADING PROCEDURES	4-6
INSTALLATION DOCK TO GROUND	7
OPERATING INSTRUCTIONS	8-11
MAINTENANCE	11-15
TROUBLE SHOOTING	15
UNDERCARRIAGE	16-17
GRATING PARTS LIST	18
HYDRAULIC PUMP PARTS	19
MOBILE RAMP SAFETY LABELS	20
DOCK TO GROUND SAFETY LABELS	21
NOTES	22-23

SAFETY

A product safety sign or label should alert persons to a specific hazard, the degree or level of hazard seriousness, the probable consequence of involvement with the hazard, and how the hazard can be avoided. **SIGNAL WORD** is a word or words that designate a degree or level of hazard seriousness. The signal words for product safety signs are “**DANGER, WARNING, CAUTION**” and “**NOTICE**”. Below is each of these signal words along with their definitions as directly referenced from *ANSI Z535.4-1998*.



Indicates an imminently hazardous situation which, if not avoided, will result in death or serious injury. This signal word is to be limited to the most extreme situations.



Indicates a potentially hazardous situation which, if not avoided, could result in death or serious injury.



Indicates a potentially hazardous situation which, if not avoided, may result in minor or moderate injury. It may also be used to alert against unsafe practices.

NOTICE!

“NOTICE” is the preferred signal word to address practices not related to personal injury. The safety alert symbol shall not be used with this signal word. As an alternative to “NOTICE”, the word “CAUTION” without the safety alert symbol may be used to indicate a message not related to personal injury.



SAFETY PRACTICES

⚠ WARNING

Read and follow all safety practices, manuals, and instructions before installing, operating or servicing the ramp. Failure to follow these safety practices and instructions could result in property or equipment damage and serious injury or death.

READ AND FOLLOW THE OPERATING INSTRUCTIONS CONTAINED IN THIS MANUAL BEFORE OPERATING THE LIFT. If you do not understand the instructions or safety practices ask your supervisor or consult the factory for assistance.

This equipment should be used and maintained only by qualified personnel.

Failure to do any of the above could result in serious injury or death.

FOR ALL MODELS

ONLY trained personnel are to operate or service ramp. Follow all procedures and warnings in the service manual or posted on the ramp.

NEVER exceed 5 mph when driving on ramp.

NEVER exceed the rated capacity of ramp.

NEVER travel on ramp unless lip is securely on dock or carrier floor and properly attach safety chains in accordance with this manual. Visually check that the lip is supported and has a minimum of 4" of overlap onto the dock or carrier floor.

DO NOT use the ramp with equipment, material or people on or in front of the ramp or lip.

DO NOT use the ramp if it looks damaged. Tell your supervisor it needs repair right away.

DO NOT use this unit to dock heights outside its intended working range.

If you have any problems or questions using the ramp, **STOP** and contact your supervisor for assistance.

DO NOT stop truck or attempt to change gears while ascending or descending ramp.

ALWAYS traverse the ramp with the forks towards the dock or elevated end.

DO NOT attempt to lift or lower the ramp lip by any

means other than described in the operation procedures contained in this manual. Keep all body parts clear of the ramp at all times and maintain a safe distance from the underside of the ramp while raising or lowering.

DO NOT operate the ramp if operation causes undue physical strain or if physical impairments could lead to undue strain in back, muscles, limbs or joints.

DO NOT use ramp if either of the chains are missing or if the chains are not securely in place.

NEVER crawl or work under, walk or drive on any ramp that is not resting on and chained to a suitably stable and sturdy support such as a carrier bed or loading dock.

FOR MOBILE CONTAINER RAMPS

DO NOT use ramp if Breather Valve is removed.

DO NOT use drive on or place any weight on ramp if release valve on pump is in the closed position.

DO NOT use ramp if carrier wheels are not chocked and support jacks under the trailer are not being used.

Many trailers have air ride suspensions that may cause the trailer to move away from the ramp during loading and unloading operations. The potential for this movement can be reduced by exhausting or "dumping" the air from the air ride suspension system before servicing the trailer. Make sure attached chains are used to secure the ramp to the trailer.

NEVER permit a carrier to pull away and allow the ramp to fall to the ground.

ALWAYS store the ramp in the lowered position.

NEVER use the positioning sleeve for towing.

NEVER skid a ramp sideways, **ALWAYS** position the ramp by rolling on its wheels.

NEVER place your hands or any body part between the ground and tow bar.

Ramp, refers to all models including Mobile Container Ramp, Yard Ramp, Dock to Ground Ramp and Steel Yard Ramp. Ramp will be used throughout this manual to describe all models.

RECOMMENDED UNLOADING PROCEDURES

Unloading Flatbed Trailer

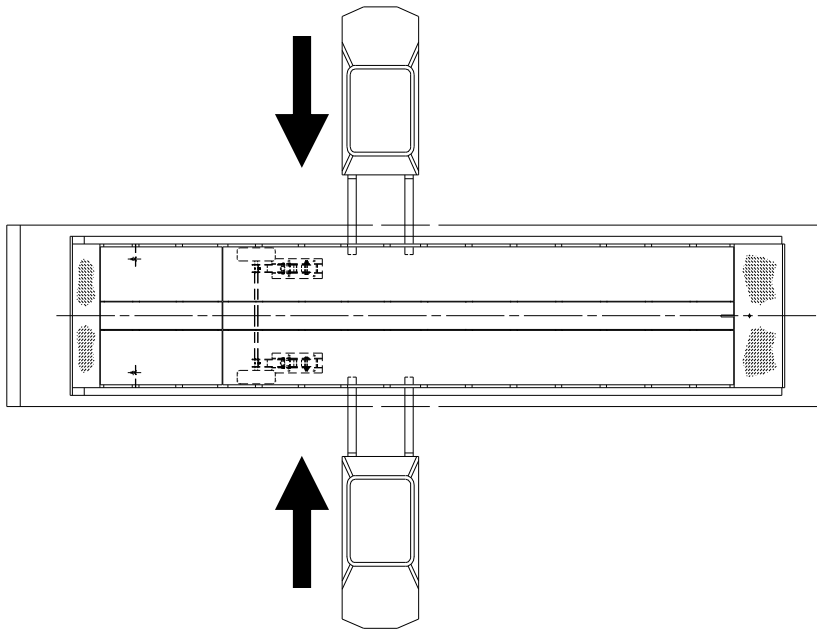

STEP #1:

After carrier comes to a complete stop and sets brakes, remove hold down straps and release ramp chains.

STEP #2:

Position lift trucks on both sides of ramp, spread forks as wide as possible. The lift truck capacity must be sufficient to lift the ramp at a distance near the fork end. See the shippers B/L for the actual weight of the ramp.

STEP #3:

Slowly move lift trucks forward. Not more than 9" of fork tip should engage the ramp side girder.

STEP #4:

Slowly and uniformly lift the ramp until it is clear of the carrier and all supports making sure ramp is balanced evenly.

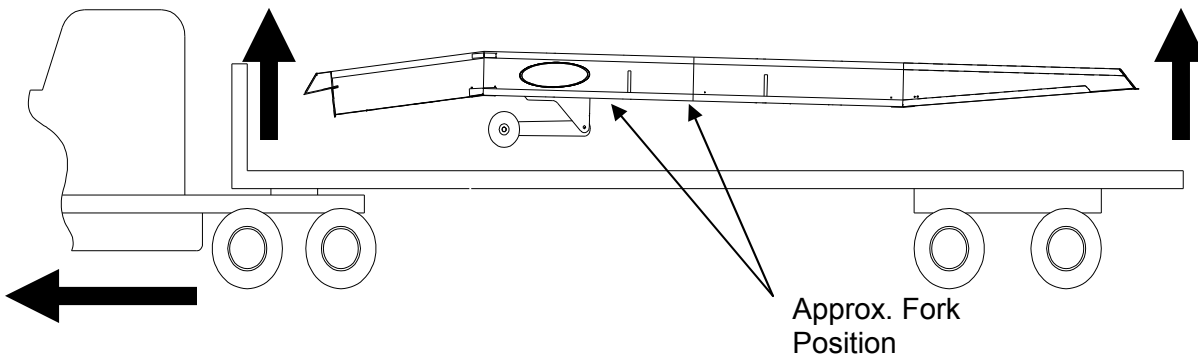

STEP #5:

Have carrier drive pull forward and completely clear of ramp. Then slowly and uniformly lower ramp to the ground.

CAUTION

When shipped some ramps have a plug in the breather location on the pump. Failure to change out the plug with the breather can cause damage to the hydraulic system and create back pressure in the tank which could result in damage to the Ramp or injury to personnel.

STEP #6:

Verify the hydraulic system works, see the OPERATION section in this manual. If there are any issues please contact the factory.

RECOMMENDED UNLOADING PROCEDURES

Unloading Box Trailer

STEP #1:

Attach chain or cable securely to ramp. Attach the other end of the chain to the mast of the fork truck. Keep chain or cable parallel with the ground to maintain better control.



Verify the fork truck has sufficient capacity to lift or pull the ramp. Failure to do so could result in personal injury or death.

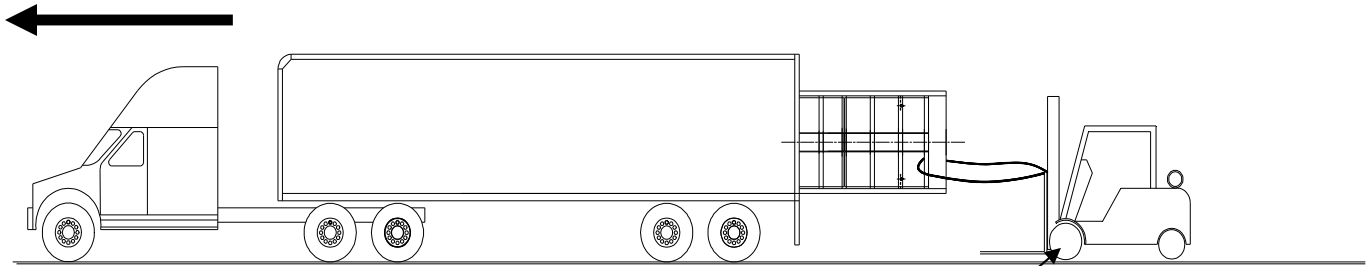

FORK TRUCK #1

STEP #2:

Slowly pull the ramp out of the box truck by driving the truck slowly forwards. Once the ramp is accessible stop. Do not pull more than half of the ramp out of the trailer without supporting the end of the ramp.

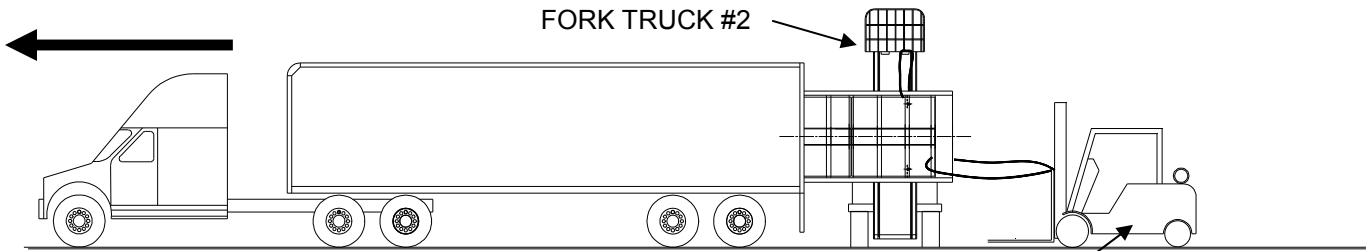

FORK TRUCK #2

FORK TRUCK #1

STEP #3:

Position Fork Truck #2 at the end of the ramp. Attach a sling from the forks to the top of the ramp and slowly raise the forks until the sling is taught. Keep the sling taught at all times.

STEP #4:

Continue to pull ramp out of the Box Trailer by driving the truck slowly forward. Once more than half of the ramp is accessible stop the truck.

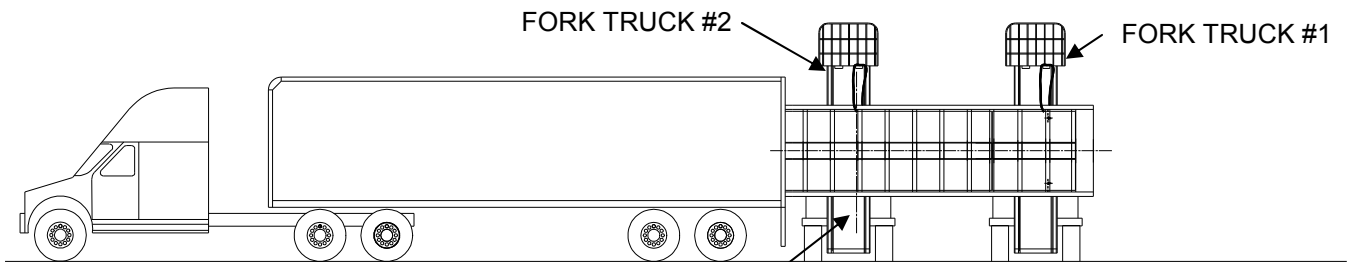

FORK TRUCK #2

FORK TRUCK #1

CENTER OF THE RAMP

STEP #5:

Reposition Fork Truck #1 and attach a sling from forks to the top of the ramp at the center of the ramp. Keep slings taught at all times. Raise the ramp until it completely clears the floor of the Box Trailer.



RECOMMENDED UNLOADING PROCEDURES

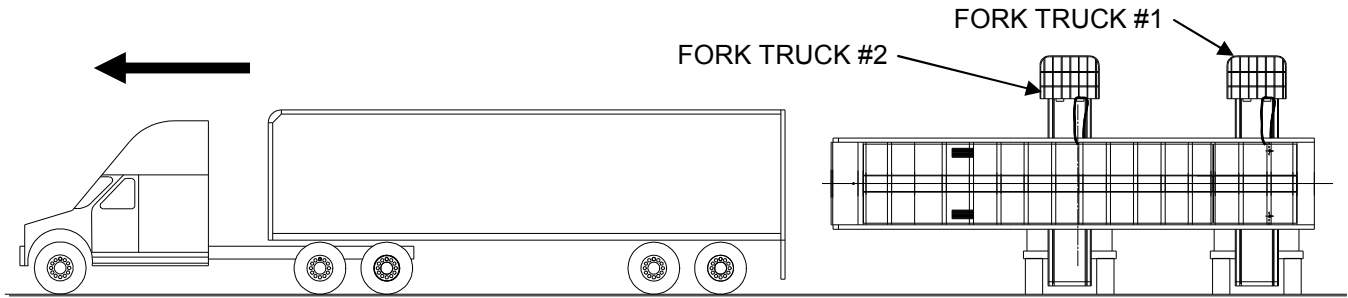

STEP #6:

Once the ramp is clear of the trailer floor slowly drive the truck forward. With the ramp clear position wood under the location of the ramp on the ground. Keep both slings taugth at all times.

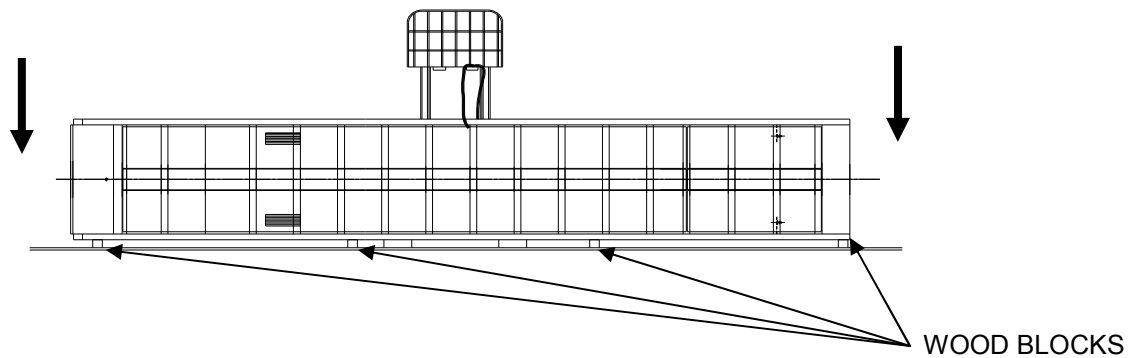

STEP #7:

Set the ramp slowly onto the wood blocks while keeping Fork Truck #2 sling taugth remove the sling from Fork Truck #1 and drive fork truck clear of ramp.

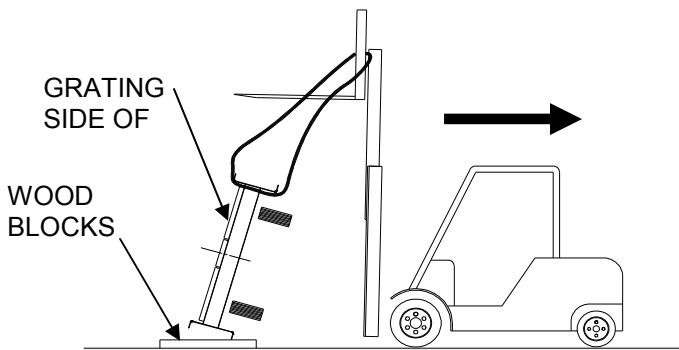

STEP #8:

Keep the ramp resting on the wood blocks and slowly back the fork truck while lowering the forks until the ramp is resting on it's wheels or bottom side. Check the ramp for any damage and **REPLACE THE PLUG WITH VENT CAP** located on the hydraulic pump on Mobile Ramps (See Figure #11).

The reservoir is equipped with a vent cap. To keep the pump from leaking during shipment the vent cap is replaced with a plug. The vent cap must be installed where the plug is located for use. (See Figure #11)

CAUTION

Failure to install the vent cap can cause damage to the hydraulic system and create back pressure in the tank which could result in damage to the Ramp or injury to personnel.

STEP #9:

Verify the hydraulic system works, see the OPERATION section in this manual. If there are any issues please contact the factory. Raise the ramp to the maximum height and lower completely a few times to remove all air in the hydraulic system from shipping.

WARNING

Read and follow all safety practices and owners manual warnings before installing, operating or servicing the Ramp. Failure to follow above information could result in death or serious injury.

INSTALLATION DOCK TO GROUND RAMP

⚠ WARNING

Read and follow all safety practices and owners manual warnings before installing, operating or servicing the Ramp.

Use by untrained personnel could result in serious injury or death. DO NOT USE THE RAMP IF IT LOOKS DAMAGED OR DOES NOT SEEM TO WORK PROPERLY. Tell your supervisor it needs repair.

Failure to follow the information provided could result in death or serious injury.

If you do not understand the instructions or if you have any problems or questions using or operating the Mobile Container Ramp, contact your supervisor or the factory for assistance.

1. PREPARE SITE:

If required, pour a concrete footer or apron per local codes and conditions. Allow to fully cure before installation of ramp. (See Figure 1).

2. INSTALL SAFETY CHAIN BRACKETS:

See Figure 3 for locating both safety chain brackets provided with Dock to Ground Ramp. Use the bracket to locate the mounting hole locations. Using 1/2" dia. anchor bolts secure safety chain brackets to the dock wall. (Anchor bolts supplied by others)

⚠ WARNING

All anchor bolt lengths must suit local codes and conditions. Type and depth of concrete will determine type and length of anchor bolts required. Improperly sized anchor bolts could allow the safety chain brackets to fail resulting in serious injury or death.

3. PLACING RAMP:

Square up and locate ramp in position on the dock surface, keeping the bumper plates as close to the dock face as possible, to prevent ramp movement. (See Figure #2).

4. ATTACH SAFETY CHAINS:

First attach both safety chains to ramp with supplied 9/16" bolts, washers and nuts. The other end of the chain slides through the "+" shaped burnout in the

chain bracket. While holding the bracket against the wall adjust the chain to allow as little amount of slack as possible. Chain to be as tight as possible to prevent the ramp from pulling away from the face of the dock. Secure both brackets to wall as show. (See Figure #2 & #3).

⚠ WARNING

Safety chains that are not attached properly may cause the ramp to move and fall free from the dock surface, resulting in equipment damage, serious injury or death.

FIGURE #1

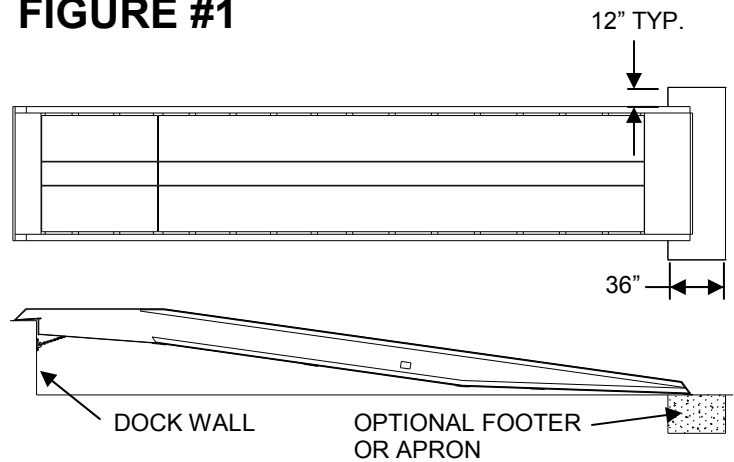
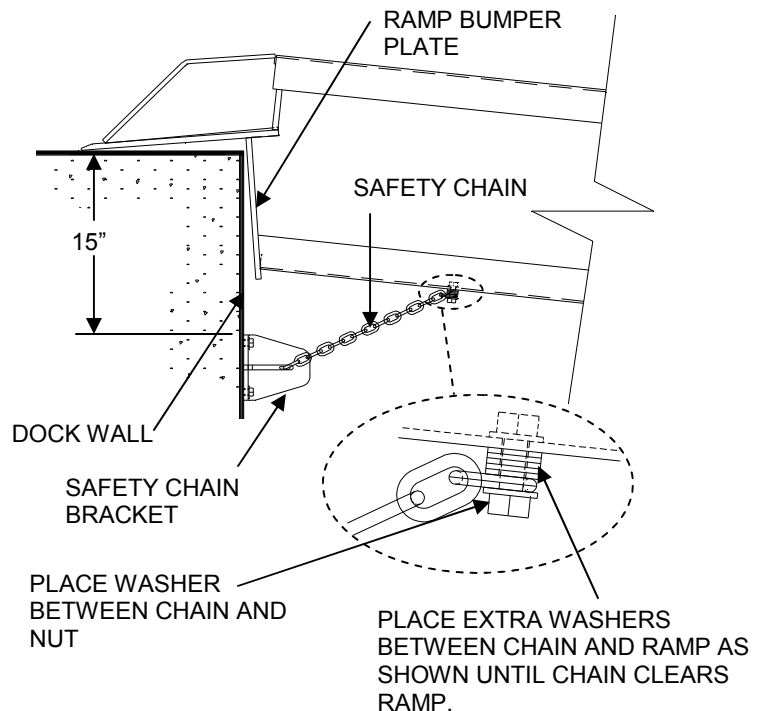
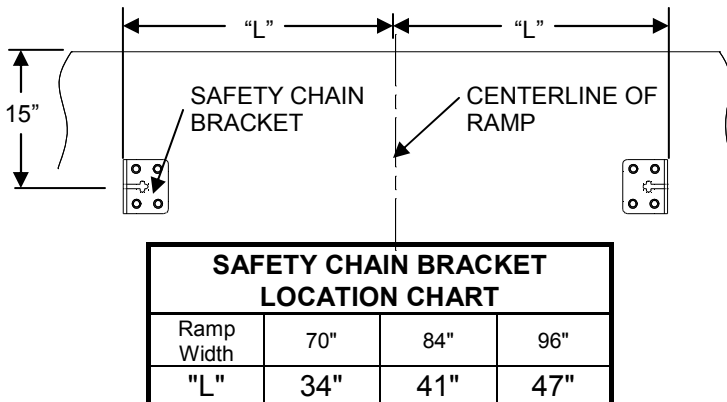

FIGURE #2



OPERATION MOBILE RAMP

FIGURE #3



POSITION. *Damage or injury can occur if the pump handle is left in the hydraulic pump.*

2. POSITION:

Move the ramp ahead until the lip apron is completely over the carrier floor, and the stop plates are against the carrier door sill. Always position the ramp to the trailer. Do not back up trailers against the ramp.

Slowly open the pump release valve by turning counter clockwise. The ramp will settle onto the carrier floor.

⚠ WARNING

The release valve must be left in the open position when the Mobile Container Ramp is in use. Failure to do so could result in death, serious injury or property damage.

This allows the understructure and hydraulics to float freely so that no load is transferred on the running gear. The ramp is designed as a single span bridge, supported at the ends only, with no load on the wheels.

Refer to the POSITIONING SLEEVE, section #8 for additional information on positioning.

3. SECURE:

Loop the two safety chains supplied on the ramp around the carrier frame and lock with grab hooks. Allow as little amount of slack in chains as possible to prevent ramp from moving away from the carrier.

⚠ WARNING

Do not use the ramp if either of the chains are missing, damaged or if the chains are not securely in place. Chock carrier wheels and use support jacks under the trailer as required. (OSHA Requirements) Accidental separation of ramp and carrier may result in serious injury or death.

If the ramp is to be used at a loading dock or other fixed platform, make sure the platform is equipped with hook or eye devices firmly anchored in place to receive the Container Ramp safety chains as outlined.

4. OPERATION (Mobile & Dock to Ground Ramps):

Verify the PUMP RELEASE VALVE is in the OPEN

OPERATION MOBILE RAMP

1. ELEVATE:

Figure #4

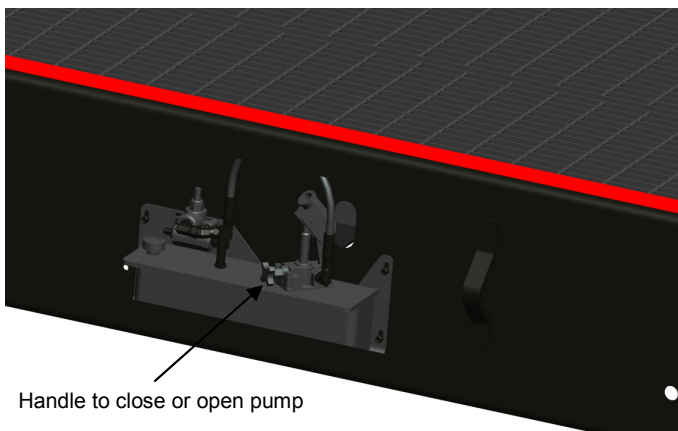

To elevate the ramp, close the pump release valve by turning the lever clockwise. The valve seat is a precision type and does not require force beyond finger tight. Overturning may damage the valve seat. The pump is located on the side of the ramp (See Figure #4).

Take the pump handle from its storage bracket on the outside of the ramp along the lower flange of the side girder. Place the handle into the opening on the pump. Raise and lower the handle in a pump action to actuate the pump. It may take a few strokes before the full pressure is felt in the handle.

Return the handle to its storage bracket when not in use.

⚠ CAUTION

DO NOT LEAVE THE HANDLE IN THE PUMPING

OPERATION MOBILE RAMP, CONTINUED

POSITION. (See Figure #3)

Approach the ramp in low gear and maintain an even rate of climbing speed.

FIGURE #5

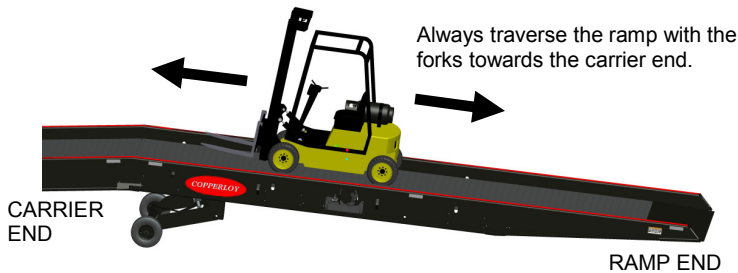

Always traverse the ramp with the forks towards the carrier or elevated end. Fork trucks should **ASCEND AND DESCEND** the ramp in **LOWEST GEAR**.

WARNING

All lift truck safety and operation standards of ASME/ANSI B56.1-1993 (incl. latest addenda) should be followed.

Do not stop, start or change speeds of truck on ramp. Failure to do so could result in death or serious injury.

5. LOADING/UNLOADING COMPLETED:

Be sure that the lift truck is off and clear from the ramp. Unhook both safety chains and disengage ramp from carrier.

WARNING

Do not walk or drive on the ramp when the ramp is not resting on a firm support at the lip end. Failure to do so could result in death or serious injury.

Unhook both safety chains from the truck frame.

Close the pump release valve (turn lever clockwise) finger tight only.

Slide the pump handle into the pump handle adapter, and pump to raise the ramp a few inches above the carrier floor.

The carrier may now pull away, or move the ramp (by means of the **Positioning Sleeve**) to the next location. **Be sure all personnel and objects are cleared from under and around the ramp before moving.**

Refer to the **Positioning Sleeve** or **Towbar** sections of this manual for correct use of these accessories.

WARNING

Never permit a carrier to pull away and allow the ramp to fall to the ground. Failure to do so will cause severe damage to the ramp and death or serious injury to personnel.

6. LOWERING THE RAMP:

Be sure that all objects and personnel are cleared from under the ramp. Slowly open the release valve to lower the ramp by turning the knob counter-clockwise. **Leave the valve in the open position.**

WARNING

Always store the ramp in the lowered position. Failure to do so could result in serious injury or death.

Do not attempt to manually lift the ramp, death or serious injury could result.

Do not place hands, head, feet or any part of person between the ground and the ramp or towbar. Failure to do so could result in death or serious injury.

7. TOWING: (TOWBAR)

If the ramp has been ordered with an optional towbar accessory, attach it to the ramp as follows:

Open the pump release valve, and let the ramp settle into the lowered position. Place the towbar hook in position between the grating panels on the lateral centerline of the ramp.

Raise the low end of the ramp until the towbar clears the ground and block it in position. Use a lift truck for all lifting.

Swing plate 'A' under the ramp approach plate.

Turn handle 'B' clockwise until tight.

When towbar is secure, ramp is ready for towing.

Recommended Towing Speed : 5 MPH Max.

OPERATION MOBILE RAMP, CONTINUED

8. POSITIONING SLEEVE:



Keep speeds under 2mph when positioning the ramp. Higher speeds could damage the positioning sleeve and cause damage to the ramp or personal injury could occur.

When the ramp is supported by the positioning sleeve DO NOT place hands, feet or any part of your body near the positioning sleeve. Keep clear while the positioning sleeve is in use.

Always inspect positioning sleeve for damage or wear before using.

If the ramp is equipped with a positioning sleeve, standard on steel frame ramps, optional on aluminum frame ramps, install it as follows:

FIGURE #6

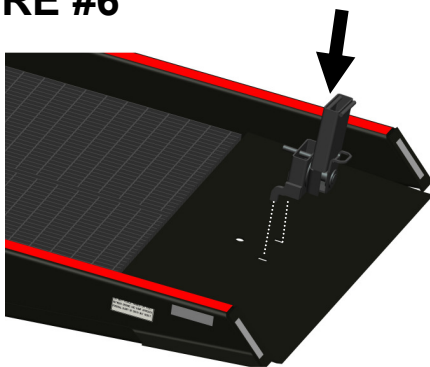

1. Stand the positioning sleeve vertical and insert the positioning sleeve lugs into the rectangular cutouts in the approach plate of the ramp.

FIGURE #7

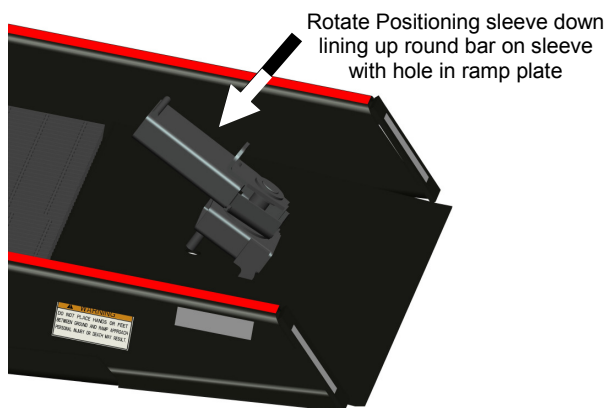

2. Swing the sleeve down flat against the plate lining up the round bar with the hole in the ramp. Insert one fork into the sleeve the full depth.

FIGURE #8

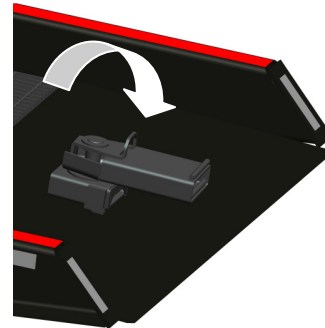

3. Rotate the top tube of the positioning sleeve around to the end of the ramp. This will position the sleeve for insertion of the fork truck.

FIGURE #9

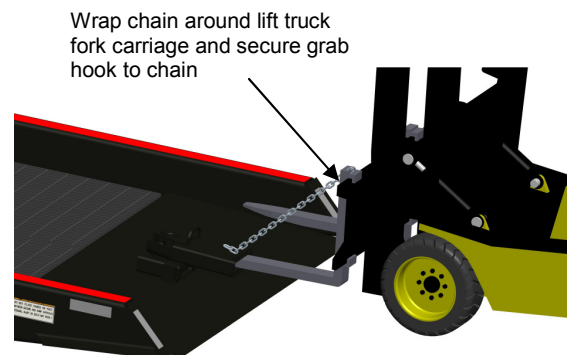

4. Attach the chain from the sleeve through the lift truck fork carriage and secure the grab hook to the chain. Remove as much slack from the chain as possible.
5. With the positioning sleeve secured, raise the forks so the ramp is 4"-6" clear of the ground.
6. Position the ramp, keep ramp 4"-6" clear of the ground and travel slowly keeping the area clear of personnel and other equipment.

Failure to do any of the above could result in equipment damage, property damage, and death or injury to personnel.

OPERATION MOBILE RAMP & MAINTENANCE

MAINTENANCE

⚠ WARNING

This Positioning Sleeve is not for towing, it is for positioning and traveling over short distances. Failure to do so could result in death or serious injury.

While positioning the ramp keep all personnel and other equipment clear.

Do not rotate positioning sleeve past 90 degrees in either direction from center.

Failure to do any of the above could result in equipment damage, property damage, and death or injury to personnel.

Positioning distances may be up to several hundred yards with this device. Beyond that distance use the TOWBAR as outlined in this manual.

⚠ WARNING

Extreme caution must be exercised when using transport devices. Attention must be given to all persons and property in the path of travel. Failure to do so could result in equipment damage, property damage, and death or serious injury.

1. BLOCKING INSTRUCTIONS:

Most maintenance work on a Ramp will be performed from the underside of the ramp. The complete hydraulic system and running gear assemblies are located below the main deck surface.

⚠ WARNING

The ramp must be supported and held securely before maintenance personnel are permitted to go under the ramp. Failure to do so could result in death or serious injury.

FIGURE #10

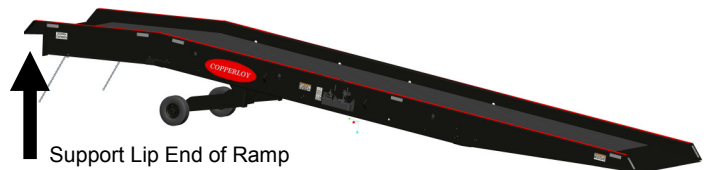

MAINTENANCE SCHEDULE			
	Schedule	Location	Description of Maintenance Performed
Structure	6 months	Entire Ramp	Inspect for damage or failure of materials or welds
Running Gear (If Applicable)	6 months	Pneumatic Tires	Maintain an air pressure of 100 psi. max.
		Solid Pneumatic Tires	Virtually Maintenance Free
Hydraulics (If Applicable)	6 months	Pump	Inspect for Damaged or excessive wear & leakage
			Check level and life of hydraulic oil
			Perform a ramp descent rate test. Measure at the lip end of the ramp the average distance per second the ramp falls when the pump release valve is opened. (Should be 6" per second if flow control is set properly)
		Hoses	Inspect for damage or leaks
		Cylinder	Damage or excessive wear & leakage
Paint	12 months	Entire Ramp	Inspect enamel finish, touch up any areas indicating rust with a rust inhibitive coating.
Grating	12 months	All Grating	Inspect for excessive wear and damage and replace as required.

Standard usage is based on servicing 1 to 2 trucks per working day. No more than 245 working days per year. Adjust maintenance schedule based on actual usage.

The support should be placed under the lip apron end and must be suitably stable and sturdy. Acceptable supports are load bearing structures such as loading docks. (See Figure #10) Do not use lumber or steel members as a vertical post brace. The safety, locking chains supplied with the ramp must also be used to secure the ramp to the supports. **DO NOT DRIVE ON THE RAMP WHEN IN THE BLOCKED POSITION.**

CAUTION

Be sure no foreign objects contaminate the hydraulic system. Damage to hydraulic system could occur.

WARNING

Before starting any maintenance on the hydraulic system open the pump by turning the pump release knob counter clockwise. Make sure all pressure has been relieved from the system before breaking any connections or removing any hoses. Hydraulic fluid under pressure can cause death or serious injury.

1. HYDRAULIC HAND PUMP/RESERVOIR:

The hydraulic system is factory filled and the vent location has a plug for shipping. Plug needs to be replaced with Vent Cap before using.

2. FILLING TANK

With the ramp in the fully lowered position, remove the vent cap from the top of the pump reservoir (See Figure #11). Be sure to clean away any foreign matter so as not to contaminate the fluid in the reservoir. Contaminated fluid is the leading cause of hydraulic system malfunction. With a funnel fill the tank through the vent cap hole location. Oil should be 1/2" to 1" from the top of the tank. Use Hydraulic Oil 46 weight or equivalent.

NOTICE!

Use only hydraulic oil. The use of any other fluid will render your warranty null and void. Units are shipped with Citgo AW-46 or similar.

CAUTION

During line bleeding with the hose fitting loosened, do not allow the ramp to raise, the

FIGURE #11

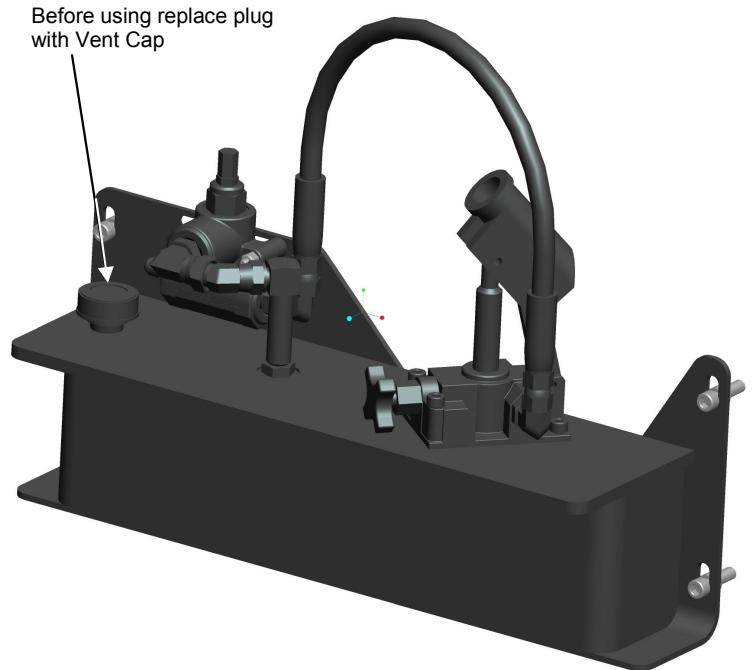

ramp could fall suddenly causing death or serious injury.

3. LINE BLEEDING:

Typically just cycling the ramp from the lowered position to the highest position a few times is enough to remove air from the hydraulic system. If air still seems to be trapped in the system continue see the following instructions.

After filling the reservoir or performing other maintenance of the hydraulic system, it may be necessary to bleed the system of entrapped air. The pump must be at its fully lowered position. Loosen the hose fitting at the cylinder and with the release valve closed, slowly operate the pump until the oil flows clear without a sign of air bubbles. Tighten the hose fitting. Add oil to the reservoir as required.

4. REMOVING HYDRAULIC CYLINDER:

Elevate the lip end of the ramp and follow "BLOCKING INSTRUCTIONS" (pg. 11). If the ramp is in the raised position, slowly open the release valve and let the ramp settle on to the support. If the ramp is to be raised by external means; the

pump release valve must be open before the ramp is elevated. **AFTER FOLLOWING THE BLOCKING INSTRUCTIONS**, disconnect the hose from the cylinder. (See Figure #15)

Remove the upper and lower cylinder retaining pins and spacers.

To install the new cylinder, pull out the rod. (If rod does not move freely, make sure hydraulic port is clear and open). Place cylinder in position, making sure that the port is at the top. Replace cylinder retaining pins and spacers. Replace hydraulic line, but do not tighten fitting. With release valve still in the open position, use a fork truck to raise the lip end of the ramp clear of the support. Remove the support and slowly lower the ramp into its lowest position. Bleed the hydraulic system as described previously, tighten hose fittings, and add oil as required. (Refer to bleeding instructions above)

5. REMOVING HYDRAULIC PUMP:

The ramp must be in the fully lowered position before starting removal. Disconnect hose from the pump. (See Figure #15)

Remove four (4) hex nuts at the back of the pump reservoir. Remove the pump from the side of the ramp. To replace the pump, reverse the procedure. After the pump is installed and attached to the system, bleed the hydraulic lines, add oil as required.

6. REPLACING GRATING:

To remove grating cut each weld that attaches the grating to the crossmembers. Make sure to remove all welds by grinding or torching making sure not to damage the crossmember.

⚠ DANGER

Damage to the crossmember will compromise the structural integrity of the ramp. Damage to the crossmembers will cause death or serious injury.

The entire piece of grating does not have to be removed, smaller lengths can be replaced. When cutting the grating make sure the cut is at the center of the crossmember. Both ends of the grating needs to be supported by a crossmember. (See Figure #12) Clean all areas by grinding flush and inspect for damage.

FIGURE #12

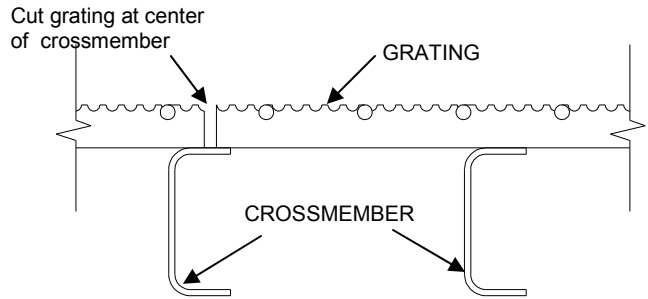

To install new grating, begin by cutting the piece of grating to length to fit area. Leave no more than 1/4" clearance on both ends. Place grating over crossmembers and space appropriately. Weld 2" long welds every other crossmember 6 times evenly spaced from side to side. Weld at both ends also. Weld from the grating to the top of the crossmember while keeping the grating flat against the crossmember. Touch up all areas with rust proofing paint. (See Figure #13)

FIGURE #13

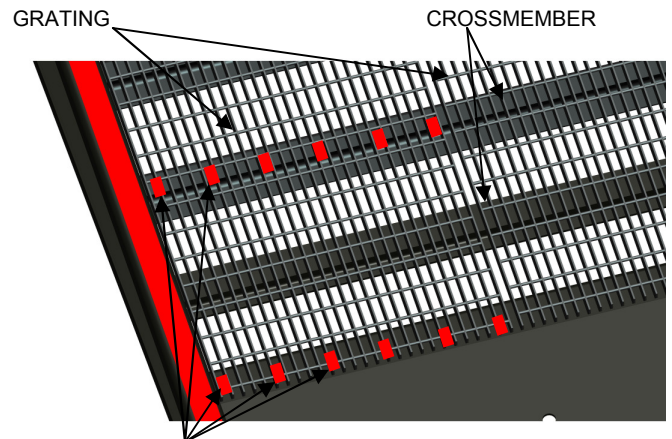

Weld 6 places 2" long from side to side of grating as shown

RUNNING GEAR

When preparing to work on any part of the wheel or axel assembly, start with the ramp in the lowest position. The pump release valve must be open. Lift the ramp at the lip end with a fork truck or other suitable means until wheels are slightly off the ground. **FOLLOW BLOCKING INSTRUCTIONS.**

5. REMOVING WHEELS:

Solid tire:

Refer to Figure #14, remove cotter pin from end of

Figure 14

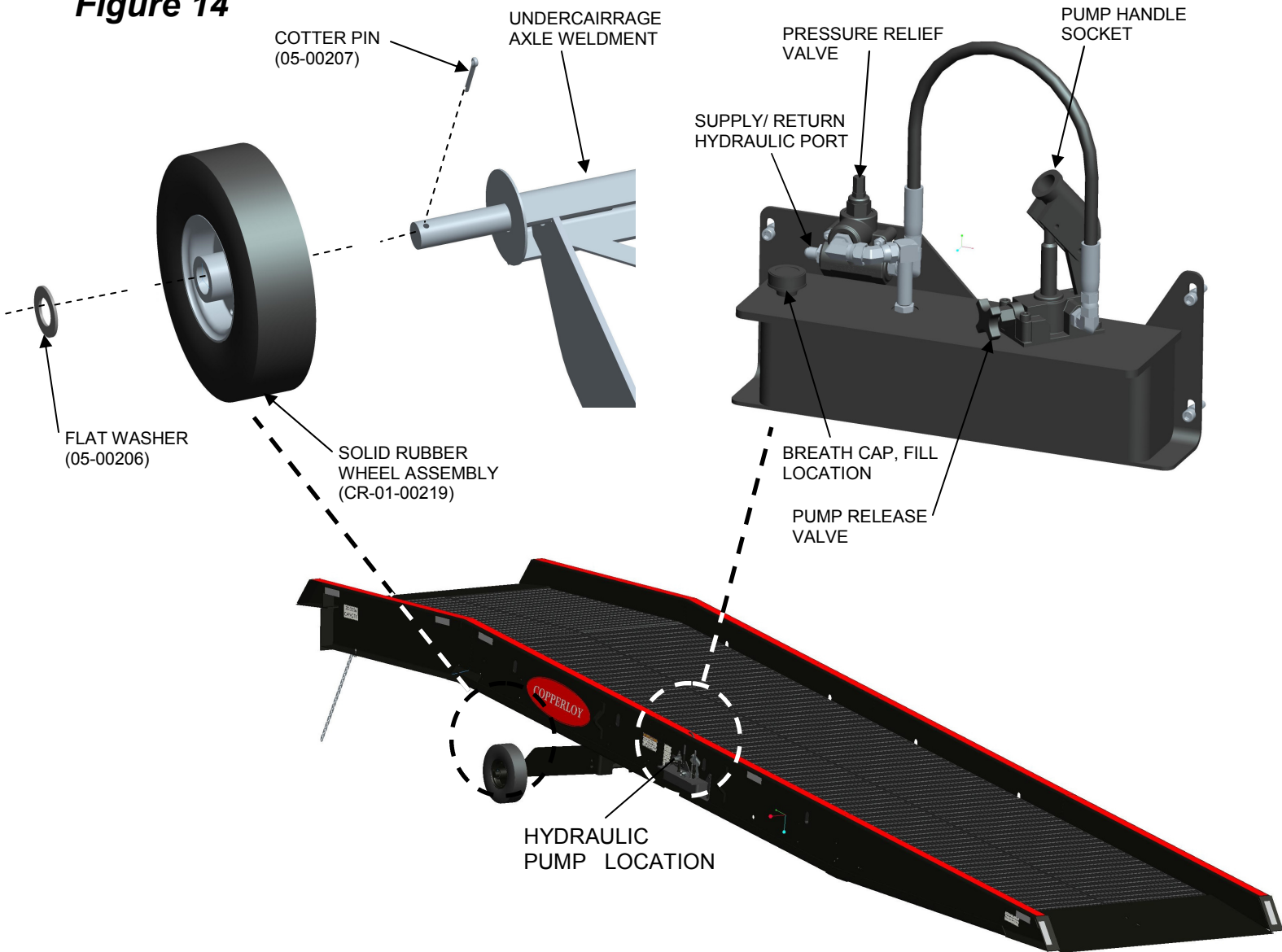

wheel axle (Item 05-00207). Slide flat washer (Item 05-00206) off wheel axle. Slide wheel (Item CR-01-00209) off wheel axle.

Before reassembly check for any damage to wheel axle or flat washers, clean any rust with emery cloth to prevent damage to new bearings.

To reassemble tire, reverse the directions above.

6. STEEL CONTAINERAMP FRAME:

Annual inspection of the steel frame’s enamel finish should be performed. Any areas indicating rust should be thoroughly wire brushed, prime painted, and top coat painted with a good quality rust

inhibiting coating. All steel products will begin to show signs of weathering at some point. This general “touch-up” is not to be considered a claim against the products warranty.



MAINTENANCE & TROUBLE SHOOTING

⚠ WARNING

No part of your body should be under the ramp while making any of these adjustments, move to safety away from the underside of the ramp.

Do not leave the flow control valve in the closed

position. This will cut off fluid flow back to the pump. This will be an unsafe condition. Do not use the ramp if it will not lower onto the carrier.

Failure to do so may result in death or serious injury.

Ramp does not raise	Check hydraulic reservoir oil level.	Fill with hydraulic oil.	See Section 1 of Hydraulic System for filling Instructions
	Check the breather vent is in the correct location and is free and clear.	Install the vent cap in the correct location or replace.	See Section 1 of Operation to open the vent cap.
	Check for damage to the hydraulic system or physical damage to the running gear.	Replace or repair damaged parts or equipment.	Refer to parts lists and figures for parts listings.
	Check pump release valve for wear or damage.	Replace or repair damaged parts or equipment.	Refer to pump parts list and figure for parts listings.
	Pressure relief valve not adjusted properly. Ramp will attempt to raise but settle back down after pumping.	Readjust pressure relief valve or replace if damaged.	See Figure #5, to increase the psi turn the hex rod on the top clockwise, to reduce turn counter-clockwise
	Hydraulic fluid could be leaking and the system losing pressure.	Check system for leaks or kinked hoses.	Repair or replace any repair any damaged or faulty parts.
Ramp rises slowly or is hard to pump	At the cylinder: Check for bent or damaged rods.	Replace cylinder	See Section 3 of Hydraulic System for Cylinder Replacement Instructions
	Check for physical damage to the running gear.	Replace or repair damaged parts or equipment.	Refer to parts lists and figures for parts listings.
	At the pump release valve: Check for damage or wear. Pump release valve may not be closing completely.	Replace or repair damaged parts or equipment.	See Section 1 of Hydraulic System
	Check the breather vent is open for operation.	Replace or install the breather cap in the correct location	See Section 1 of Operation to see correct location for the breather cap.
	Check hydraulic oil. Oil could be incorrect viscosity, contaminated or low.	Refill or replace as needed.	See Section 1 of Hydraulic System for filling Instructions
	Check for foreign objects jammed in the running gear or under the ramp.	Remove any foreign objects.	
Ramp does not lower	At the cylinder: Check for bent or damaged rods.	Replace cylinder	See Section 3 of Hydraulic System for Cylinder Replacement Instructions
	Check for physical damage to the running gear.	Replace or repair damaged parts or equipment.	Refer to parts lists and figures for parts listings.
	At the pump release valve: Check for damage or wear.	Replace or repair damaged parts or equipment.	See Section 1 of Hydraulic System
	Check the breather vent is open for operation.	Replace or install the breather cap in the correct location	See Section 1 of Operation to see correct location for the breather cap.
	Verify the flow control is working properly.	Make sure it is installed in the correct direction flow restriction is only on the way down.	Replace if damaged or not working properly. Flow Control is non-adjustable.
	Check for foreign objects jammed in the running gear or under the ramp.	Remove any foreign objects.	
Oil Leakage	At the cylinder: Check for scored rod, wear or damage to cylinder.	Replace cylinder	See Section 3 of Hydraulic System for Cylinder Replacement Instructions
	At the pump filler plug: Check Oil level, too much oil in the reservoir due to improper filling will cause excess oil to be forced out of the vent.	Remove Oil from reservoir.	See Section 1 of Hydraulic System for filling Instructions
	At the pump release valve: Check for damage or wear.	If damage is noticed	See Section 1 of Hydraulic System to replace pump

Figure 15

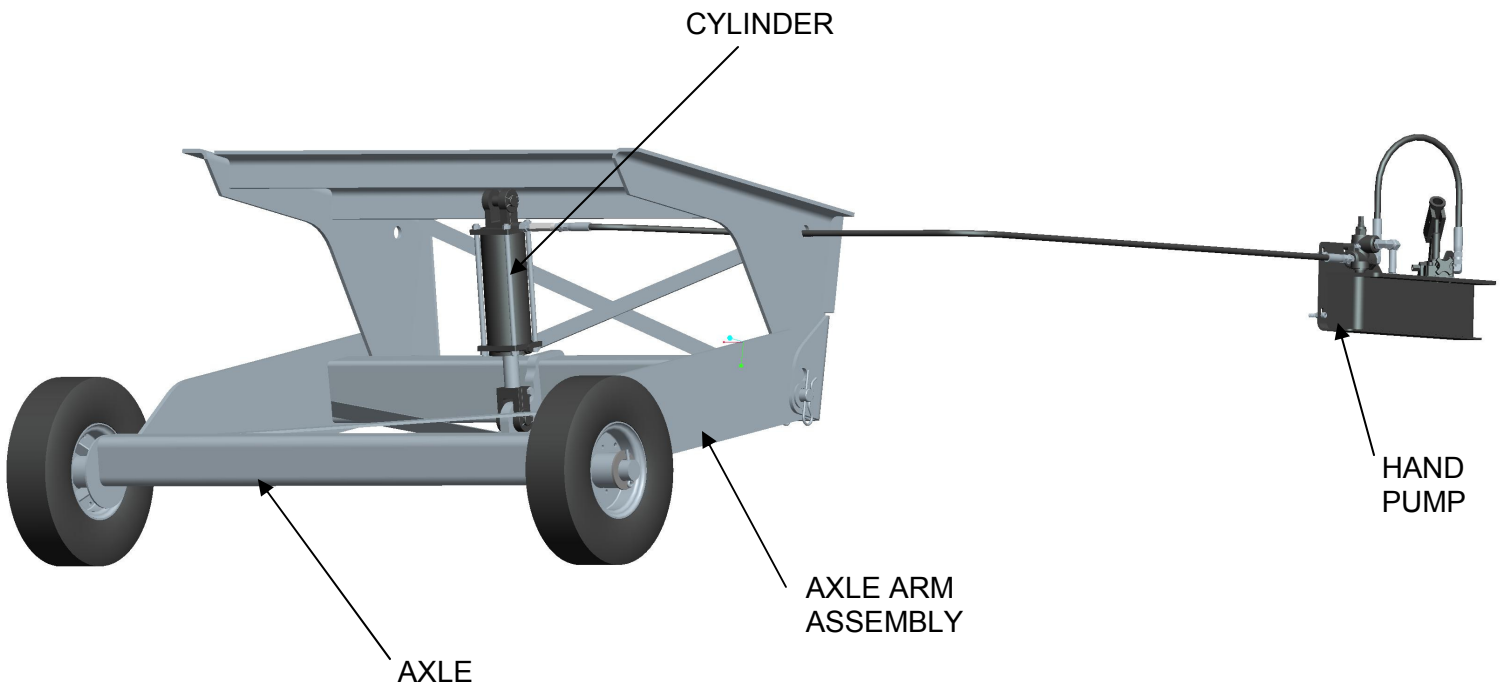

ITEM NO.	QTY.	DESCRIPTION	JH PART NO.
1	2	FLAT WASHER, 2"	05-00206
2	2	COTTER PIN, 3/8"x3-1/2"	05-00207
3	2	SYR, 1-1/2" CLEVIS PIN	05-00208
4	4	HAIRPIN COTTER PIN, 1-1/2" DIA. SHAFT	05-00209
5	4	FLAT WASHER, 1-1/2"	05-00210
6	1	SYR HYDRAULIC CYLINDER	08-00015
7	1	JIC 3/8" MALE TO SAE O-RING #6 STRAIGHT	08-00018
8	1	SAE O-RING #6 MALE TO SAE O-RING #6 MALE STRAIGHT	08-00019
9	1	SAE O-RING #8 MALE TO SAE O-RING #6 FEMALE REDUCER	08-00020
10	1	PUMP TO CYLINDER HOSE ASSMBLY, JIC x JIC	08-00023
11	1	FLOW CONTROL	203-522
13	1	SYR UNDERCAIRRRAGE ARM WELDMENT	CR-01-00205
14	1	SYR UNDERCAIRRRAGE BASE WELDMENT	CR-01-00206
15	2	SYR, WHEEL ASSEMBLY, SOLID RUBBER, 18"	CR-02-00219
16	2	SYR UNDERCAIRRRAGE BASE ANGLES	CR-02-01034_48
24	1	SYR HYD. CYLINDER MOUNTING BRACKET GUSSET (Based on Capacity and Size)	
25	1	SYR LOWER HYD. CYLINDER MOUNTING BRACKET (Based on Capacity and Size)	

UNDERCARRIAGE ASSEMBLY

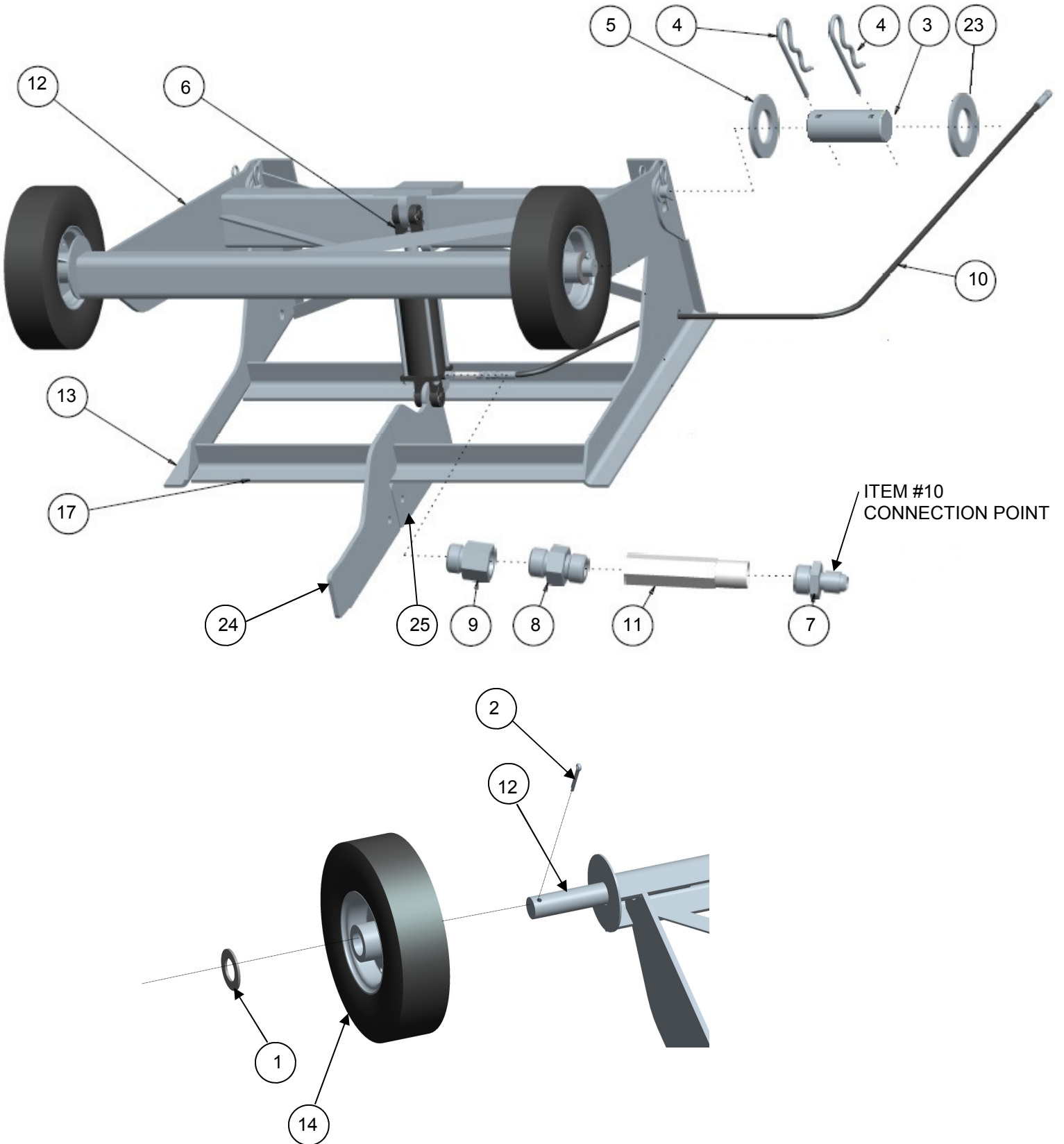

GRATING PARTS LIST

STEEL RAMPS

ITEM NO.	30' STRAIGHT RAMP						36' RAMP WITH 8' LEVEL OFF						39' STRAIGHT RAMP						DESCRIPTION	PART NUMBER			
	SYR/SDGXX-70-30STR	SYR/SDGXX-84-30STR	SYR/SDGXX-96-30STR	SYR/SDGXX-102-30STR	SYR/SDGXX-108-30STR	SYR/SDGXX-118-30STR	SYR/SDGXX-120-30STR	SYR/SDGXX-70-36PL8	SYR/SDGXX-84-36PL8	SYR/SDGXX-96-36PL8	SYR/SDGXX-102-36PL8	SYR/SDGXX-108-36PL8	SYR/SDGXX-118-36PL8	SYR/SDGXX-120-36PL8	SYR/SDGXX-70-36STR	SYR/SDGXX-84-36STR	SYR/SDGXX-96-36STR	SYR/SDGXX-102-36STR			SYR/SDGXX-108-36STR	SYR/SDGXX-118-36STR	SYR/SDGXX-120-36STR
1							2															Grating, 1-3/4" Thick, 28-11/16" Wide, 74.25" lg.	CR-02-00648
2								2				1	3	3								Grating, 1-3/4" Thick, 35-13/16" Wide, 74.25" lg.	CR-02-00630
3														2		3	3	2				Grating, 1-3/4" Thick, 28-11/16" Wide, 112-1/2" lg.	CR-02-00649
4														2	2			1	3	3		Grating, 1-3/4" Thick, 35-13/16" Wide, 112-1/2" lg.	CR-02-00650
5	2		3	3	2		2		3	3	2			2		3	3	2				Grating, 1-3/4" Thick, 28-11/16" Wide, 299-1/4" lg.	CR-02-00647
6	2	2			1	3	3	2	2			1	3	3	2	2			1	3	3	Grating, 1-3/4" Thick, 35-13/16" Wide, 299-1/4" lg.	CR-02-00629

ALUMINUM RAMPS

ITEM NO.	30' STRAIGHT RAMP			36' RAMP WITH 8' LEVEL OFF			DESCRIPTION	PART NUMBER
	A SXX-70-30STR	A SXX-84-30STR	A SXX-96-30STR	A SXX-70-36PL8	A SXX-84-36PL9	A SXX-96-36PL8		
1				2		3	Grating, 2-1/4" Thick, 28-3/4" Wide, 74.25" lg.	025-026
2					2	3	Grating, 2-1/4" Thick, 14-1/2" Wide, 74.25" lg.	025-028
3	2		3	2		3	Grating, 2-1/4" Thick, 28-3/4" Wide, 299-1/4" lg.	025-025
4		2			2		Grating, 2-1/4" Thick, 14-1/2" Wide, 299-1/4" lg.	025-027
5	40	50	60	50	60	70	Cap Screw, Grating Hold Down (5/16-18NC x 3"LG)	002-078
6	40	50	60	50	60	70	Lock Nut, Grating Hold Down (5/16-18NC)	024-010
7	40	50	60	50	60	70	Clamp, Grating Hold Down	025-007

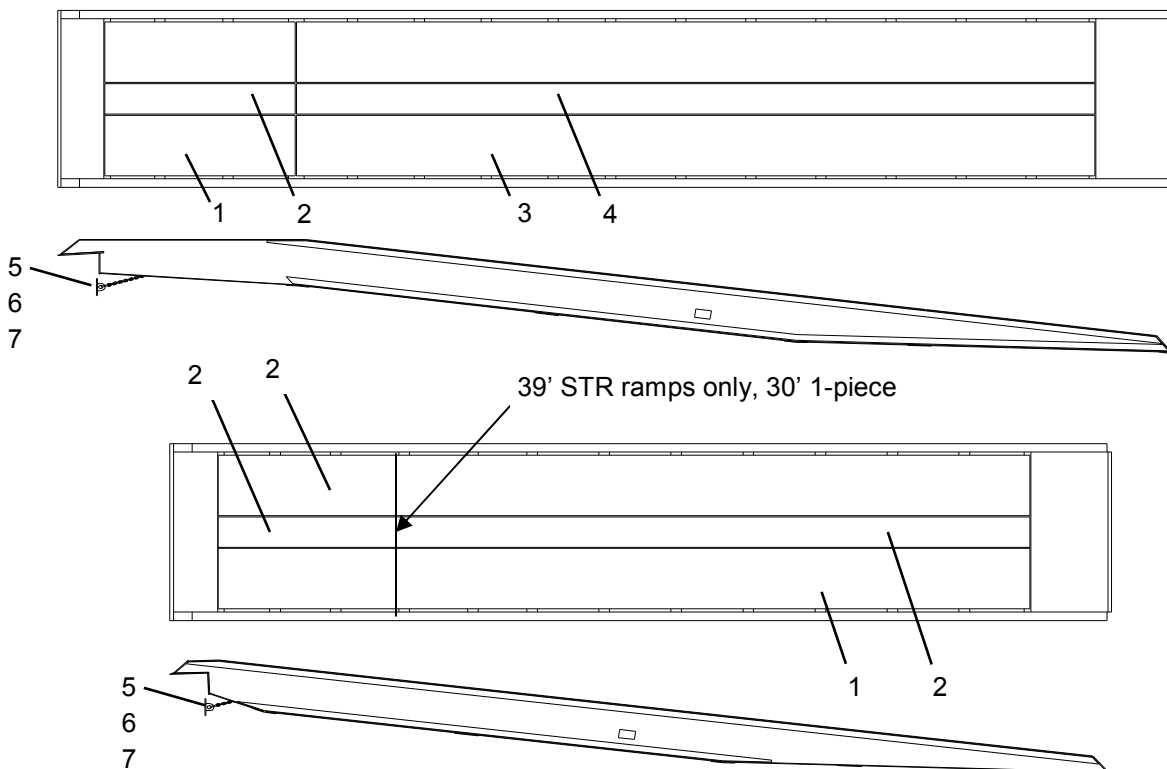

PUMP ASSEMBLY

ITEM NO.	QTY.	DESCRIPTION	JH PART NO.
1	2	F.H.C.S., 1/4"-20x2", Znc. Pltd.	05-00200
2	2	Nylon-Insert Locknut, 1/4"-20, Znc. Pltd.	05-00201
3	4	S.H.C.S., 3/8"-16x1-1/2", Znc. Pltd.	05-00202
4	4	Nylon-Insert, Locknut, 3/8"-16, Znc. Pltd.	05-00203
5	1	Relief Valve	08-00001
6	1	#8 SAE/ORB Male x 1/2" JIC Female 90 Degree	08-00002
7	1	1/2" JIC Male x 1/2" JIC Female 45 Degree	08-00003
8	1	Male JIC X Male BOSS 90 Degree Extra Extra Long	08-00004
9	1	Hydraulic Breather Cap, SYR Tank	08-00005
10	1	Hand Pump Assembly	08-00006
11	1	3/8" Male JIC x 3/8" Adj. Male BSPP 90 Degree	08-00007
12	1	18" Hydraulic Hose Assembly, SYR Hydraulics	08-00011
13	1	JIC 6M x SAE 8M 90 Degree Elbow Swivel	08-00017
14	1	3/8" JIC Male x #8 SAE/ORB Male Straight	08-00018
15	1	Steel Yard Ramp Hydraulic Pump Tank Weldment	CR-01-00207

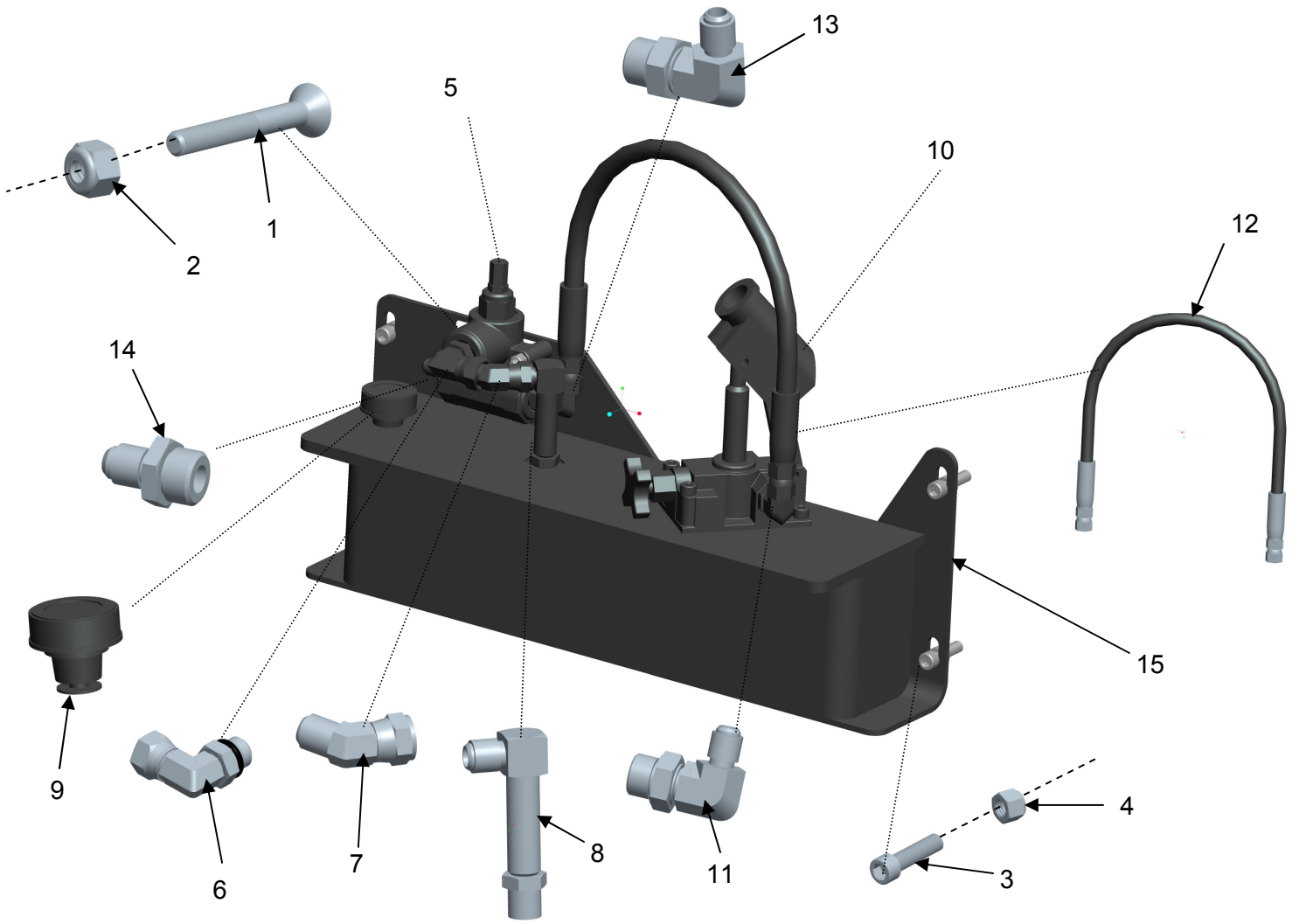

MOBILE RAMP SAFETY LABELS

ITEM NO	QTY.	DESCRIPTION	PART NO.
1	2	Capacity Label	12-00102
2	2	Safety Chain Warning Label	12-00101
3	2	Copperloy Logo Label	033-025
4	1	Operation Warning Label	12-00106
5	1	Mobile Containerramp Operating Instructions Label	12-00103
6	2	Approach Ramp Area Label	12-00104
7	1	Safety Stripping Kit	12-00099
8	1	Pump Warning Label	12-00105
9	1	Serial Label	033-004

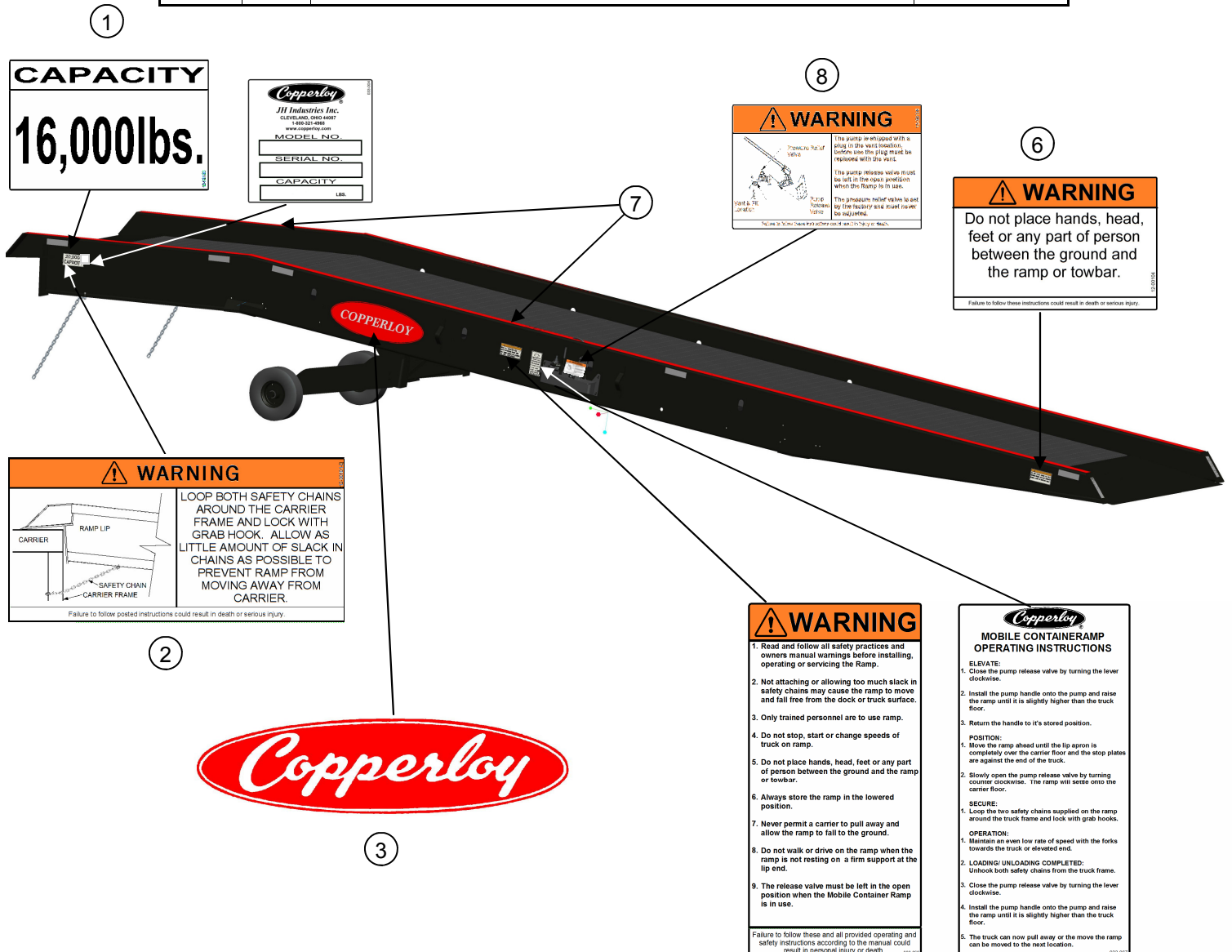



DOCK TO GROUND SAFETY LABELS

ITEM NO	QTY.	DESCRIPTION	PART NO.
1	2	Capacity Label	12-00102
2	2	Safety Chain Warning Label	12-00100
3	2	Copperloy Logo Label	033-025
4	2	Approach Ramp Area Label	12-00104
5	1	Safety Stripping Kit	12-00099
6	1	Serial Label	033-004

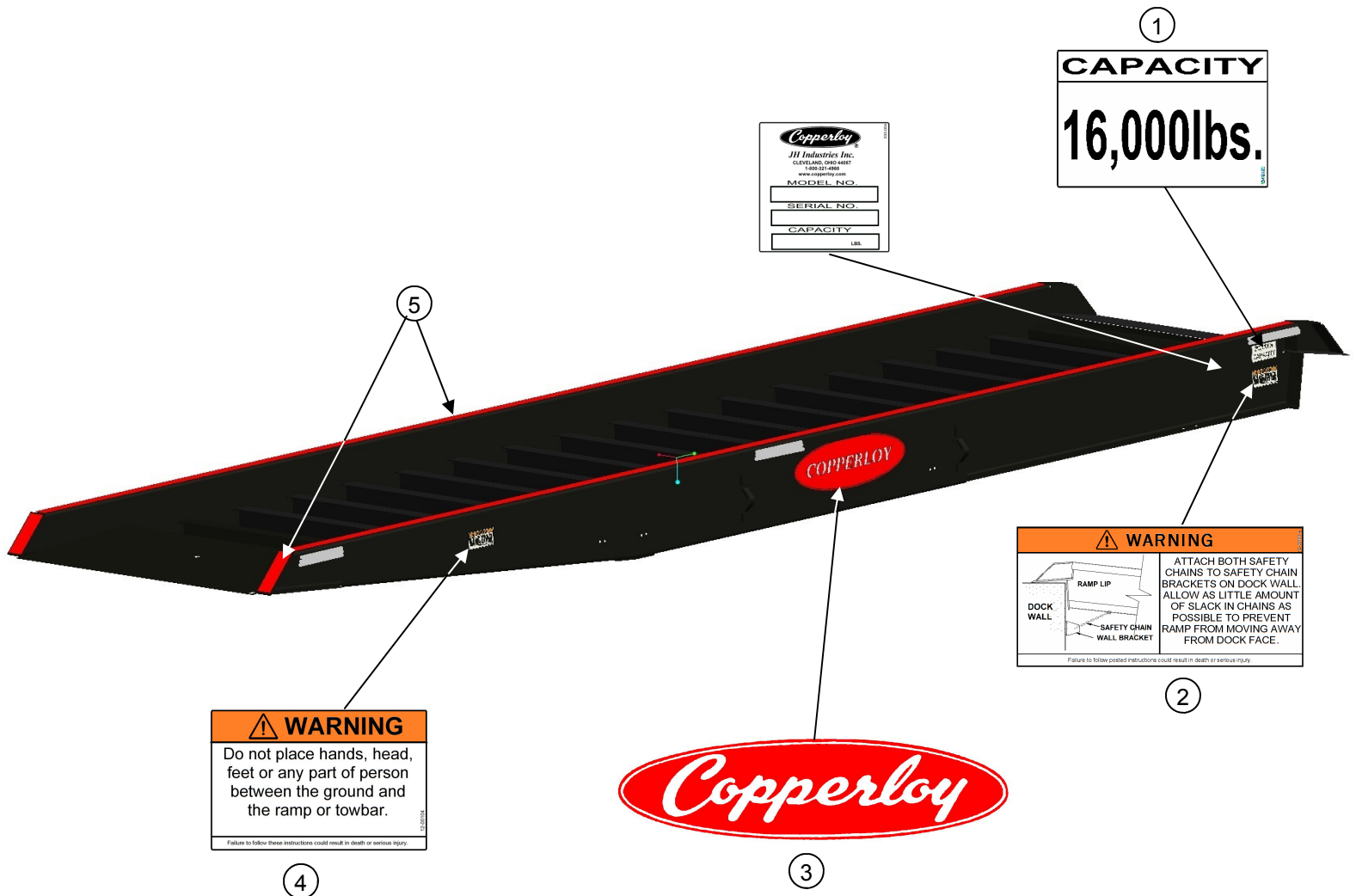



www.copperloy.com/loading-dock-equipment/yard-ramps/



JH Industries, Inc.
1981 E. Aurora Road
Twinsburg, OH 44087

Phone: 1-330-963-4105

Fax: 1-330-963-4111

Toll Free: 1-800-321-4968

www.copperloy.com