

A Division of Systems, Inc.

POWERAMP[®]

Premium Loading Dock Systems

VH SERIES

Dock Leveler

Owner's/User's Manual





POWERAMP • Division of Systems, Inc. • W194 N11481 McCormick Drive • Germantown, WI 53022
800.643.5424 • fax: 262.257.7399 • www.docksystemsinc.com • techservices@docksystemsinc.com

Table of Contents

	Page
Safety	
Recognize Safety Information	1
General Operational Safety Precautions	1
Operational Safety Precautions.....	2
Maintenance Safety Precautions.....	4
Safety Decals.....	5
Owner's User's Responsibilities	6
Introduction	
General Information.....	7
Dock Leveler Stock Specifications	7
Component Identification.....	8
Theory	8
Installation	
Prepare Pit	10
Prepare Dock Leveler	11
Install Dock Leveler	12
Install Control Panel and Wiring	18
Put New Leveler Into Service.....	19
Operation	
Operating Instructions	20
Ramp Loading/Unloading Instructions	21
End Loading/Unloading Instructions	22
Maintenance	
Service Dock Leveler Safely	23
Periodic Maintenance	24
Adjustments	
Adjust Main Pressure Relief	26
Adjust Cable Weight and Down Speed Control.....	27
Adjust Auto Return To Dock (ARTD).....	28
Troubleshooting	
Troubleshooting.....	31
Parts	
Controls	35
Frame and Platform	36
Hydraulic Components.....	38
Hoist Cylinder Repair Parts	40
Lip Cylinder Repair Parts.....	41
Logic Block Assembly	42
Power Pack Assembly.....	44
Weather Seals	46
Miscellaneous	
Customer Information	49
Warranty.....	Back Cover

Recognize Safety Information

Safety-Alert Symbol

The <u>Safety-Alert Symbol</u> identifies important safety messages on equipment, safety signs, in manuals, or elsewhere. When you see this symbol, be alert to the possibility of personal injury or death. Follow the instructions in the safety message.

 DANGER
The use of the word <u>DANGER</u> signifies the presence of an extreme hazard or unsafe practice which will most likely result in severe injury or death.

 WARNING
The use of the word <u>WARNING</u> signifies the presence of a serious hazard or unsafe practice which may result in serious injury or death.

 CAUTION
The use of the word <u>CAUTION</u> signifies possible hazard or unsafe practice which could result in personal injury.

IMPORTANT
The use of the word <u>IMPORTANT</u> is to draw attention to a procedure that needs to be followed to prevent machine damage.

General Operational Safety Precautions

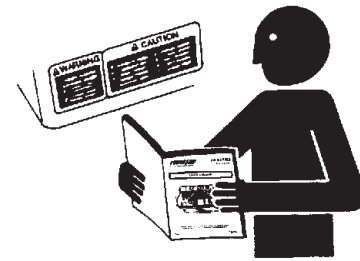

Read and understand the operating instructions and become thoroughly familiar with the equipment and its controls before operating the dock leveler.

Never operate a dock leveler while a safety device or guard is removed or disconnected.

Never remove DANGER, WARNING, or CAUTION signs or decals on the equipment unless replacing them.

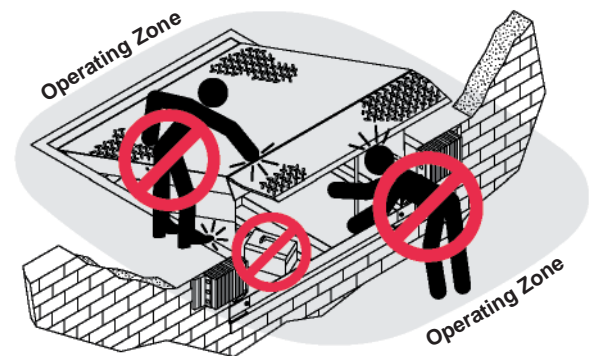

Do not start the equipment until all unauthorized personnel in the area have been warned and have moved outside the operating zone.

Remove any tools or foreign objects from the operating zone before starting.

Keep the operating zone free of obstacles that could cause a person to trip or fall.

SAFETY

Operational Safety Precautions



Learn the safe way to operate this equipment. Read and understand the manufacturer's instructions. If you have any questions, ask your supervisor.

DANGER



Stay clear of dock leveling device when freight carrier is entering or leaving area.



Do not move or use the dock leveling device if anyone is under or in front of it.

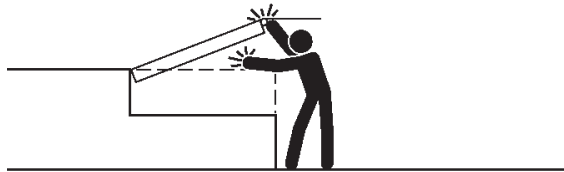

Keep hands and feet clear of pinch points. Avoid putting any part of your body near moving parts.

WARNING



Chock/restrain all freight carriers. Never remove the wheel chocks until loading or unloading is finished and truck driver has been given permission to drive away.



Do not use a broken or damage dock leveling device. Make sure proper service and maintenance procedures have been performed before using.

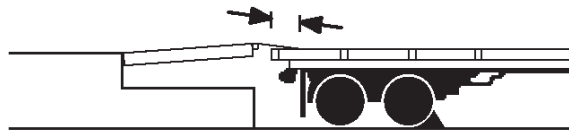

Make sure lip overlaps onto trailer at least 4 in. (102 mm).

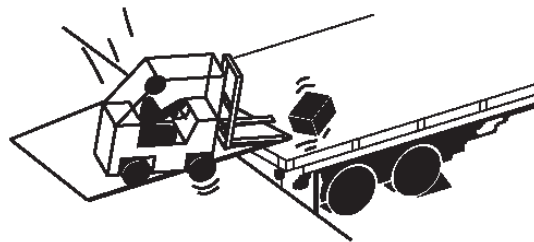

Keep a safe distance from both side edges.

⚠ WARNING

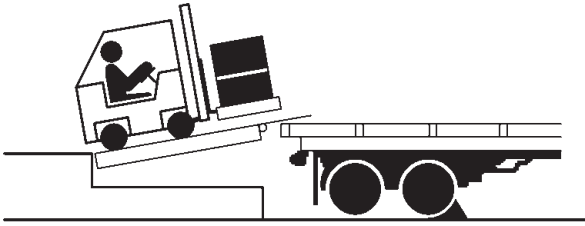

Do not use dock leveling device if freight carrier is too high or too low.

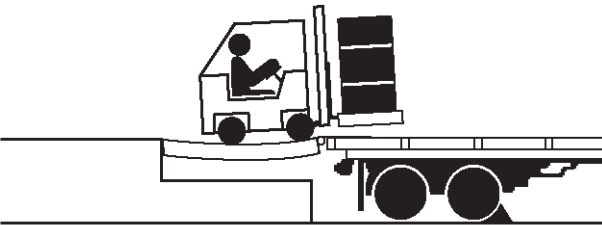

Do not overload the dock leveling device.

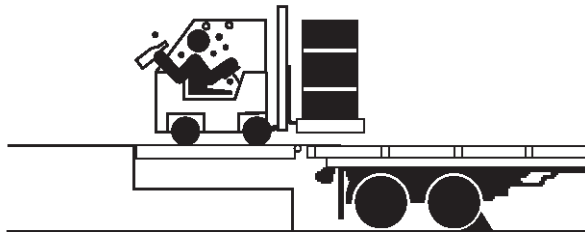

Do not operate any equipment while under the influence of alcohol or drugs.

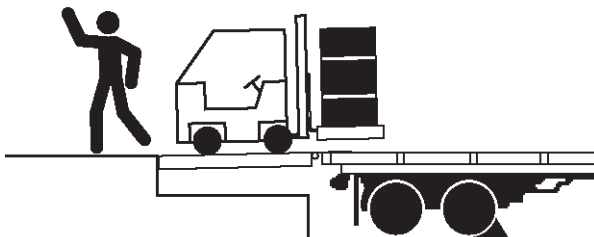

Do not leave equipment or material unattended on dock leveling device.

SAFETY

Maintenance Safety Precautions

⚠ DANGER

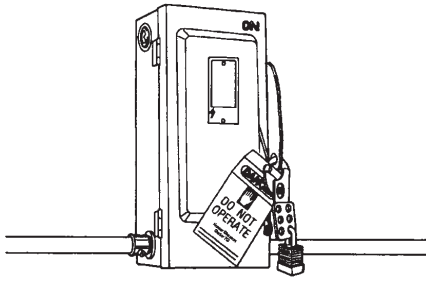

Hydraulic and electrical power must be OFF when servicing the equipment. For maximum protection, use an OSHA approved locking device to lock out all power sources. Only the person servicing the equipment should have the key to unlock the device.

⚠ CAUTION



Always post safety warnings and barricade the work area at dock level and ground level to prevent unauthorized use of the unit before maintenance is complete.

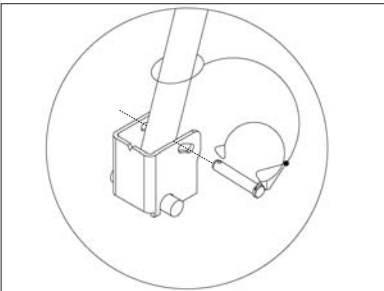

The maintenance prop must be in the upright “service” position when working under the dock leveler. For maximum protection, use an OSHA approved locking device to lock the maintenance prop in the service position. Only the person servicing the equipment should have the key to unlock the device.

⚠ WARNING

ALWAYS disconnect electrical power source and ground wire before welding on dock leveler.

DO NOT ground welding equipment to any hydraulic or electrical components of the dock leveler. Always ground to the dock leveler frame.

Failure to follow these instructions may result in damage to dock leveler and/or serious personal injury or death.

⚠ WARNING

DO NOT grind or weld if hydraulic fluid or other flammable liquid is present on the surface to be ground or welded

DO NOT grind or weld if uncontained hydraulic fluid or other flammable liquid is present. Stray sparks can ignite spills or leaks near the work area. Always clean up the oil leaks and spills before proceeding with grinding or welding.

Always keep a fire extinguisher of the proper type nearby when grinding or welding.

Failure to follow these instructions may result in serious personal injury or death.

⚠ WARNING

ALWAYS stand clear of dock leveler lip when working in front of the dock leveler. Failure to do this may result in serious personal injury or death.

⚠ DANGER



Arc Flash and Shock Hazard
PPE (Personal Protection Equipment) Required









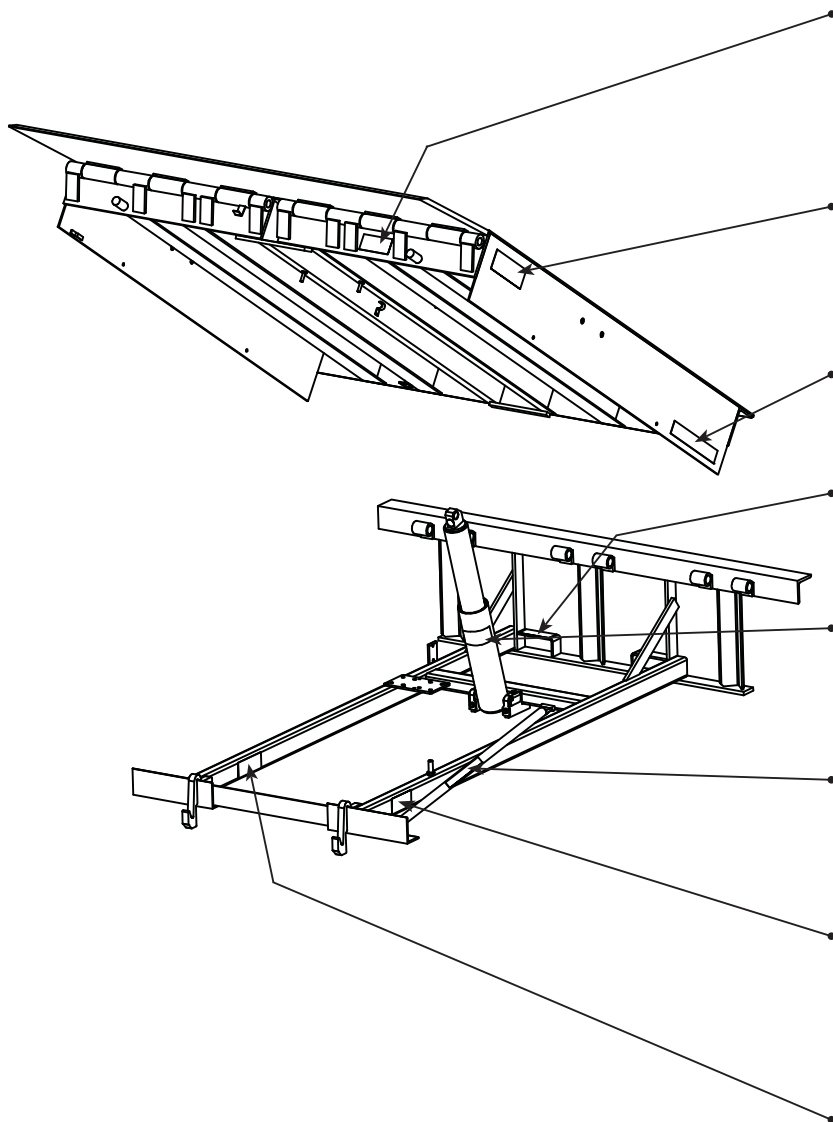























De-energize equipment before working on or inside. Do not open cover without appropriate PPE. Refer to NFPA 70E for PPE requirements. This panel may contain more than one power source.

Hazardous Voltage Will Cause Severe Injury or Death

Safety Decals

Every 90 days (quarterly) inspect all safety labels and tags to ensure they are on the dock leveler and are easily legible. If any are missing or require replacement, please call 1-800-643-5424 for replacements.



<p>1751-0727</p>	<table border="1"> <thead> <tr> <th colspan="2" style="background-color: #f08080; color: white;">⚠ DANGER</th> </tr> </thead> <tbody> <tr> <td style="vertical-align: top;">  </td> <td style="vertical-align: top;"> <p>CRUSH HAZARD Maintenance prop must support leveler behind bar. Do not force maintenance prop forward of bar to support tip. Refer to owner's/user's manual for proper use. Failure to comply will result in death or serious injury.</p> </td> </tr> <tr> <td colspan="2" style="text-align: right;">  </td> </tr> </tbody> </table>	⚠ DANGER			<p>CRUSH HAZARD Maintenance prop must support leveler behind bar. Do not force maintenance prop forward of bar to support tip. Refer to owner's/user's manual for proper use. Failure to comply will result in death or serious injury.</p>		
⚠ DANGER							
	<p>CRUSH HAZARD Maintenance prop must support leveler behind bar. Do not force maintenance prop forward of bar to support tip. Refer to owner's/user's manual for proper use. Failure to comply will result in death or serious injury.</p>						
							
<p>1751-0730 (x2)</p>	<table border="1"> <thead> <tr> <th colspan="2" style="background-color: #f08080; color: white;">⚠ DANGER</th> </tr> </thead> <tbody> <tr> <td style="vertical-align: top;">  </td> <td style="vertical-align: top;"> <p>SAFETY INFORMATION</p> <p>1. Read and follow all instructions and warnings on the equipment. Failure to do so may result in death or serious injury.</p> <p>2. Always use proper tie-down technique. Always use proper tie-down technique. Always use proper tie-down technique.</p> <p>3. Always use proper tie-down technique. Always use proper tie-down technique. Always use proper tie-down technique.</p> <p>4. Always use proper tie-down technique. Always use proper tie-down technique. Always use proper tie-down technique.</p> <p>5. Always use proper tie-down technique. Always use proper tie-down technique. Always use proper tie-down technique.</p> <p>6. Always use proper tie-down technique. Always use proper tie-down technique. Always use proper tie-down technique.</p> <p>7. Always use proper tie-down technique. Always use proper tie-down technique. Always use proper tie-down technique.</p> <p>8. Always use proper tie-down technique. Always use proper tie-down technique. Always use proper tie-down technique.</p> <p>9. Always use proper tie-down technique. Always use proper tie-down technique. Always use proper tie-down technique.</p> <p>10. Always use proper tie-down technique. Always use proper tie-down technique. Always use proper tie-down technique.</p> </td> </tr> <tr> <td colspan="2" style="font-size: small;"> <p>Failure to follow posted instructions will result in death or serious injury.</p> </td> </tr> </tbody> </table> <p style="text-align: center;"><i>(decal placed in same position on both sides)</i></p>	⚠ DANGER			<p>SAFETY INFORMATION</p> <p>1. Read and follow all instructions and warnings on the equipment. Failure to do so may result in death or serious injury.</p> <p>2. Always use proper tie-down technique. Always use proper tie-down technique. Always use proper tie-down technique.</p> <p>3. Always use proper tie-down technique. Always use proper tie-down technique. Always use proper tie-down technique.</p> <p>4. Always use proper tie-down technique. Always use proper tie-down technique. Always use proper tie-down technique.</p> <p>5. Always use proper tie-down technique. Always use proper tie-down technique. Always use proper tie-down technique.</p> <p>6. Always use proper tie-down technique. Always use proper tie-down technique. Always use proper tie-down technique.</p> <p>7. Always use proper tie-down technique. Always use proper tie-down technique. Always use proper tie-down technique.</p> <p>8. Always use proper tie-down technique. Always use proper tie-down technique. Always use proper tie-down technique.</p> <p>9. Always use proper tie-down technique. Always use proper tie-down technique. Always use proper tie-down technique.</p> <p>10. Always use proper tie-down technique. Always use proper tie-down technique. Always use proper tie-down technique.</p>	<p>Failure to follow posted instructions will result in death or serious injury.</p>	
⚠ DANGER							
	<p>SAFETY INFORMATION</p> <p>1. Read and follow all instructions and warnings on the equipment. Failure to do so may result in death or serious injury.</p> <p>2. Always use proper tie-down technique. Always use proper tie-down technique. Always use proper tie-down technique.</p> <p>3. Always use proper tie-down technique. Always use proper tie-down technique. Always use proper tie-down technique.</p> <p>4. Always use proper tie-down technique. Always use proper tie-down technique. Always use proper tie-down technique.</p> <p>5. Always use proper tie-down technique. Always use proper tie-down technique. Always use proper tie-down technique.</p> <p>6. Always use proper tie-down technique. Always use proper tie-down technique. Always use proper tie-down technique.</p> <p>7. Always use proper tie-down technique. Always use proper tie-down technique. Always use proper tie-down technique.</p> <p>8. Always use proper tie-down technique. Always use proper tie-down technique. Always use proper tie-down technique.</p> <p>9. Always use proper tie-down technique. Always use proper tie-down technique. Always use proper tie-down technique.</p> <p>10. Always use proper tie-down technique. Always use proper tie-down technique. Always use proper tie-down technique.</p>						
<p>Failure to follow posted instructions will result in death or serious injury.</p>							
<p>1751-0329 (x2)</p>	<table border="1"> <tbody> <tr> <td colspan="2" style="text-align: center; background-color: #ffff00; color: black; font-weight: bold; font-size: 1.2em;">  DO NOT FORK THIS SIDE  </td> </tr> <tr> <td colspan="2" style="text-align: center;"><i>(decal placed in same position on both sides)</i></td> </tr> </tbody> </table>	 DO NOT FORK THIS SIDE 		<i>(decal placed in same position on both sides)</i>			
 DO NOT FORK THIS SIDE 							
<i>(decal placed in same position on both sides)</i>							
<p>1751-0330 (x2)</p>	<table border="1"> <tbody> <tr> <td colspan="2" style="text-align: center; background-color: #ffff00; color: black; font-weight: bold; font-size: 1.2em;">  FORK HERE </td> </tr> <tr> <td colspan="2" style="text-align: center;"><i>(decal placed in same position on both sides)</i></td> </tr> </tbody> </table>	 FORK HERE		<i>(decal placed in same position on both sides)</i>			
 FORK HERE							
<i>(decal placed in same position on both sides)</i>							
<p>1751-0138</p>	<table border="1"> <thead> <tr> <th colspan="2" style="background-color: #f08080; color: white;">⚠ DANGER</th> </tr> </thead> <tbody> <tr> <td colspan="2"> <p>CRUSH HAZARD DO NOT REMOVE hydraulic cylinder until leveler is safely supported by maintenance prop. Refer to owner's/user's manual for proper maintenance procedure. Failure to comply will result in death or serious injury.</p> </td> </tr> </tbody> </table>	⚠ DANGER		<p>CRUSH HAZARD DO NOT REMOVE hydraulic cylinder until leveler is safely supported by maintenance prop. Refer to owner's/user's manual for proper maintenance procedure. Failure to comply will result in death or serious injury.</p>			
⚠ DANGER							
<p>CRUSH HAZARD DO NOT REMOVE hydraulic cylinder until leveler is safely supported by maintenance prop. Refer to owner's/user's manual for proper maintenance procedure. Failure to comply will result in death or serious injury.</p>							
<p>1751-0729</p>	<table border="1"> <thead> <tr> <th colspan="2" style="background-color: #f08080; color: white;">⚠ DANGER</th> </tr> </thead> <tbody> <tr> <td style="vertical-align: top;">  </td> <td style="vertical-align: top;"> <p>CRUSH HAZARD Do not work under dock leveler unless this maintenance prop has been secured in the upright position. See owner's/user's manual for proper procedures. Failure to comply will result in death or serious injury.</p> </td> </tr> <tr> <td colspan="2" style="text-align: right;">  </td> </tr> </tbody> </table>	⚠ DANGER			<p>CRUSH HAZARD Do not work under dock leveler unless this maintenance prop has been secured in the upright position. See owner's/user's manual for proper procedures. Failure to comply will result in death or serious injury.</p>		
⚠ DANGER							
	<p>CRUSH HAZARD Do not work under dock leveler unless this maintenance prop has been secured in the upright position. See owner's/user's manual for proper procedures. Failure to comply will result in death or serious injury.</p>						
							
<p>1751-0731</p>	<table border="1"> <thead> <tr> <th colspan="2" style="background-color: #f08080; color: white;">⚠ DANGER</th> </tr> </thead> <tbody> <tr> <td style="vertical-align: top;">  </td> <td style="vertical-align: top;"> <p>CRUSH HAZARD Rotate prop to maintenance position. Open the pin latch and insert through the maintenance prop housing. Close the pin latch to secure prop. Use every time dock leveler is serviced. Failure to comply will result in death or serious injury.</p> </td> </tr> <tr> <td colspan="2" style="text-align: right;">  </td> </tr> </tbody> </table>	⚠ DANGER			<p>CRUSH HAZARD Rotate prop to maintenance position. Open the pin latch and insert through the maintenance prop housing. Close the pin latch to secure prop. Use every time dock leveler is serviced. Failure to comply will result in death or serious injury.</p>		
⚠ DANGER							
	<p>CRUSH HAZARD Rotate prop to maintenance position. Open the pin latch and insert through the maintenance prop housing. Close the pin latch to secure prop. Use every time dock leveler is serviced. Failure to comply will result in death or serious injury.</p>						
							
<p>1751-0726</p>	<table border="1"> <thead> <tr> <th colspan="2" style="background-color: #f08080; color: white;">⚠ DANGER</th> </tr> </thead> <tbody> <tr> <td style="vertical-align: top;">  </td> <td style="vertical-align: top;"> <p>CRUSH HAZARD DO NOT ENTER PIT unless dock leveler is safely supported by maintenance prop. Place barriers on driveway and dock floor to indicate service work being performed. Refer to owner's/user's manual for proper maintenance procedures. Failure to comply will result in death or serious injury.</p> </td> </tr> </tbody> </table>	⚠ DANGER			<p>CRUSH HAZARD DO NOT ENTER PIT unless dock leveler is safely supported by maintenance prop. Place barriers on driveway and dock floor to indicate service work being performed. Refer to owner's/user's manual for proper maintenance procedures. Failure to comply will result in death or serious injury.</p>		
⚠ DANGER							
	<p>CRUSH HAZARD DO NOT ENTER PIT unless dock leveler is safely supported by maintenance prop. Place barriers on driveway and dock floor to indicate service work being performed. Refer to owner's/user's manual for proper maintenance procedures. Failure to comply will result in death or serious injury.</p>						

OWNER'S/USER'S RESPONSIBILITIES

1. The owner/ user should recognize the inherent dangers of the interface between the loading dock and the transportation vehicle. The owner/ user should, therefore, train and instruct all operators in the safe operation and use of the loading dock equipment in accordance with manufacturer's recommendations and industry standards. Effective operator training should also focus on the owner's/user's company policies and operating conditions. Maintaining, updating and re training all operators on safe working habits and operation of the equipment, regardless of previous experience, should be done on a regular basis and should include an understanding and familiarity with all functions of the equipment. Owner's/user's shall actively maintain, update and retrain all operators on safe working habits and operations of the equipment.
2. The manufacturer shall provide to the initial purchaser all necessary information regarding Safety Information, Operation, Installation and Safety Precautions, Recommended Initial and Periodic Inspections Procedures, Planned Maintenance Schedule, Product Specifications, Troubleshooting Guide, Parts Break Down, Warranty Information, and Manufacturers Contact Information, as well as tables to identify the grade(slope) for all variations of length or configuration of the dock leveling device and information identifying the maximum uncontrolled drop encountered when sudden removal of support while in the working range of the equipment.
3. It is recommended that when the transportation vehicle is positioned correctly in the dock opening and in contact with both bumpers, there shall be a minimum of 4.00 inches (100mm) overlap of the leveling device and the transportation vehicle at all times during the loading and unloading process.
4. The Owner/User must review all name plates, placards, decals, instructions and posted warnings and place the same in view of the operator or maintenance personnel for whom such warnings are intended for. Contact manufacturer for any replacements.
5. Manufacturer's recommended periodic maintenance and inspection procedures in effect at the date of shipment shall be followed at all times. Written documentation of maintenance, replacement parts or damage should be retained. In the event of damage notification to the manufacturer is required.
6. Loading dock equipment that has been structurally damaged or has experienced a sudden loss of main support while under load (such as what might occur when a transport vehicle pulls out from under the leveling device) shall be removed from service, inspected by a manufacturer's authorized representative, and repaired or replaced as needed before being placed back in service.
7. Any modifications or alterations of loading dock equipment shall only be done with prior written approval from the manufacturer and the same shall be at least as safe as the original equipment was prior to the modification and shall also satisfy all safety requirements of the manufacturer for the particular application of the leveling device.
8. When industrial moving devices are being used in the loading or unloading of product from the transportation vehicle, this vehicle shall have the brakes and wheel chocks applied appropriately or all other positive restraining device shall be fully utilized. It is recommended that trailers with air-ride suspension systems shall have its air exhausted prior to performing loading and unloading operation to minimize trailer bed drop.
9. Loading dock safety equipment should never be used outside of its intended use, vertical working range, or capacity. Please consult the manufacturer if you have any questions as to the use, vertical working range or capacity of the equipment. Only properly trained and authorized personnel should operate the equipment.
10. When selecting loading dock safety equipment, it is important to consider not only present requirements but also future plans and any possible adverse conditions, environmental factors or usage.

General Information

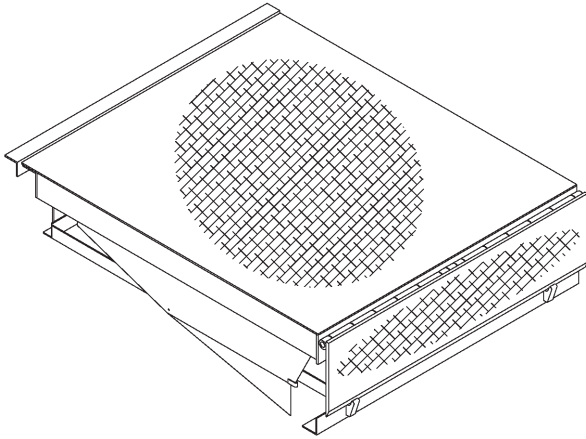

Congratulations on your choice of a Poweramp dock leveler. This manual covers the VH series hydraulic dock leveler.

Designed by Poweramp to be a marvel of simplicity and efficiency, your dock leveler, when properly installed, will provide many years of trouble-free performance with an absolute minimum of maintenance. Its revolutionary hydraulic system efficiently controls and operates every function. To obtain maximum performance and longest possible use, a simple program of preventive maintenance is recommended.

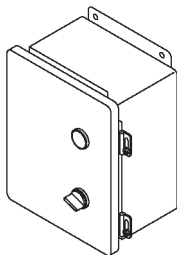

The VH series dock leveler comes equipped with an electrical control panel, which allows push button operation of the dock leveler functions. Each VH dock leveler unit and control panel has been factory prewired and tested to ensure satisfactory operation.

To illustrate which connections are to be made in the field at installation, electrical drawings are included with each order or by contacting Poweramp Technical Services.

Once again, thank you and congratulations on your purchase of a Poweramp hydraulic dock leveler.

Dock Leveler Stock Specifications

VH dock levelers are available in the following sizes, weight capacities, and options:

Width: VH

- 6 ft (1828.8 mm)
- 6-1/2 ft (1981.2 mm)
- 7 ft (2133.6 mm)

Length

- 6 ft (1828.8 mm)
- 8 ft (2438 mm)
- 10 ft (3048 mm)
- 12 ft (3658 mm)

Capacity (CIR*)

- 25,000 lb (11 340 kg)
- 30,000 lb (13 608 kg)
- 35,000 lb (15 876 kg)
- 40,000 lb (18 144 kg)
- 45,000 lb (20 412 kg)
- 50,000 lb (22 680 kg)
- 60,000 lb (27 216 kg)

* CIR (Comparative Industry Rating)

Call Poweramp to discuss available voltages, phases and options to meet your specific needs.

INTRODUCTION

Component Identification

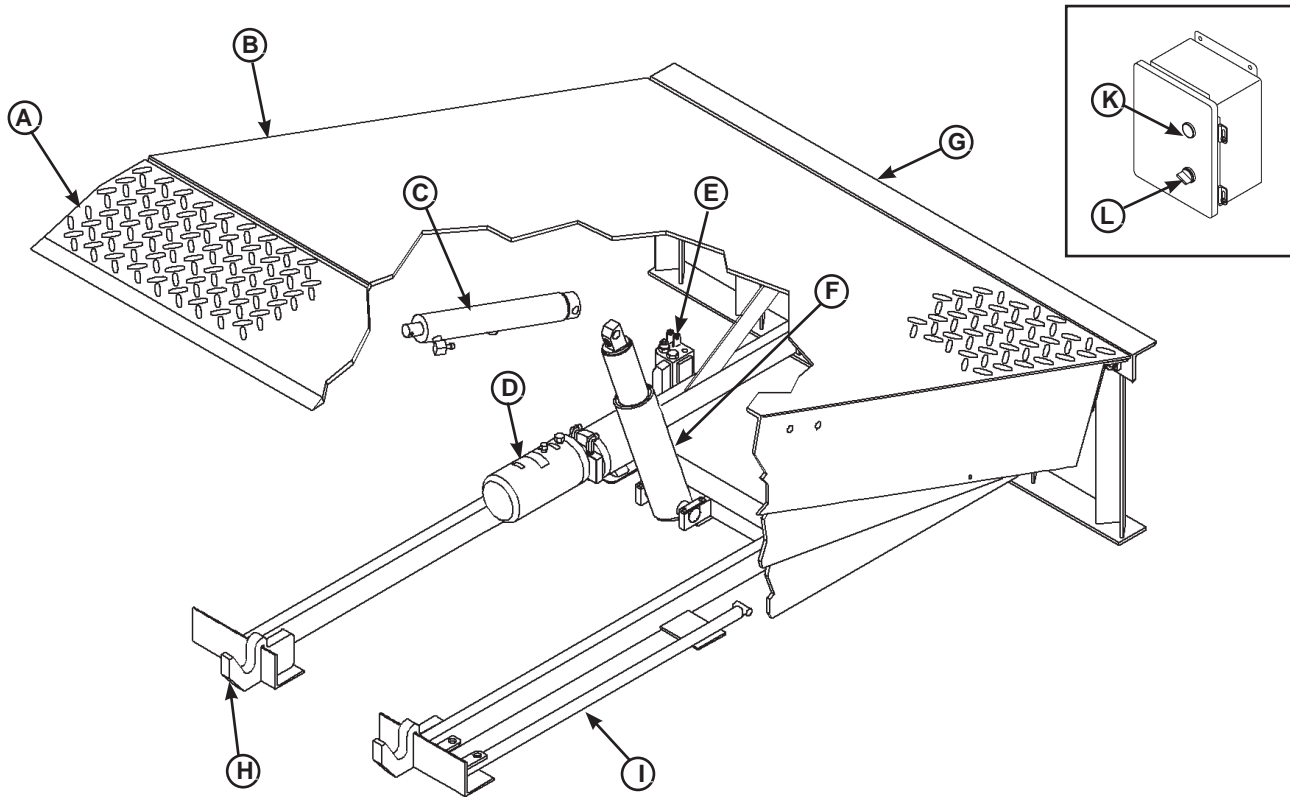

- | | | | |
|----------------------|--------------------------------------|--------------------------|--------------------------|
| A — Lip | D — Powerpack (Motor/Pump/Reservoir) | G — Main Frame | J — Toe Guard (2 used) |
| B — Platform | E — Logic Block | H — Lip Keepers (4 used) | K — Raise Button |
| C — Lip Cylinder(s)* | F — Platform Cylinder(s)* | I — Maintenance Prop | L — ARTD Switch (option) |

THEORY

The VH dock leveler uses hydraulic logic and one-button operation for ease of use.

The dock leveler can be operated remotely using the RAISE button (J) on the control panel .

Platform (B) is raised by pushing and holding the RAISE button (K). This activates an electric motor (D) which, in turn, drives a hydraulic pump. The hydraulic pump forces oil into the platform cylinder(s) (F), causing the platform to rise. Releasing the RAISE button allows the platform to lower.

When the platform rises to the point where there is 1 — 3 in. (25.4 — 76.2 mm) of travel left in the platform cylinder, a cable pulls the valve lever up. When the cable force exceeds the force necessary to shift the spool valve inside logic block (E), the spool shifts, causing oil to be redirected to the lip cylinder(s) (C). This causes the platform to stop rising and lip (A) to extend. When the lip has fully extended, the platform will continue to rise until it reaches the full raised position.

This page intentionally left blank

INSTALLATION

Prepare Pit

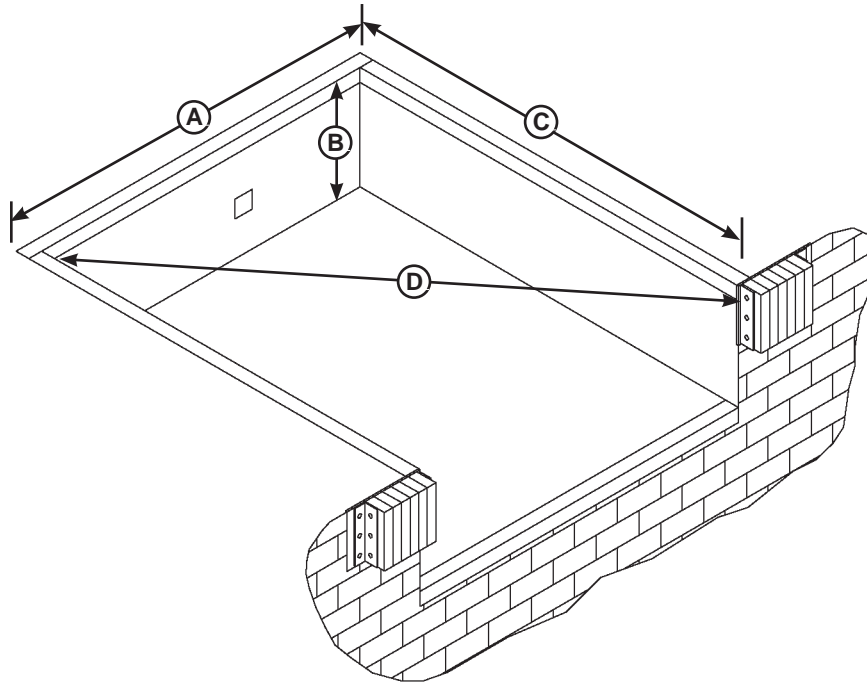

A—Distance (Pit Width)
(Front and Rear)

B— Distance (Dock Floor-to-Pit
Floor) (All Four Corners)

C— Distance (Pit Length)
(Both Sides of Pit)

D— Distance (Pit Corner-to-Corner) (Top,
Bottom, and Both Sides)



WARNING

Post safety warnings and barricade the work area at dock level and ground level to prevent unauthorized use of the dock leveler before installation has been completed.

Failure to follow the installation instructions can result in damage to dock leveler, the facilities, and/or serious personal injury or death.



CAUTION

Only trained installation professionals with the proper equipment should install this product.

IMPORTANT

DO NOT remove the shipping bands around the dock leveler lip until instructed to do so.

Before lowering the dock leveler into the pit, the following must be performed:

1. Remove all debris from the pit and sweep the pit clean.
2. Check the entire dock leveler pit for proper construction according to approved/certified pit drawings. Make sure pit is square by making the following measurements:

- Measure pit width distance (A) at both front and rear of pit.
- Measure dock floor-to-pit floor distance (B) at all four corners.
- Measure pit length distance (C) at both sides.
- Measure corner-to-corner (criss-cross) distance (D) at both sides. Take measurements at dock floor level and at pit floor level.

If any measurement is off by more than 1/8 in. (3.18 mm), contact Poweramp Technical Services before proceeding.

3. Make sure the field junction box for the dock leveler (E) is at the correct location per pit diagrams.

Prepare Dock Leveler

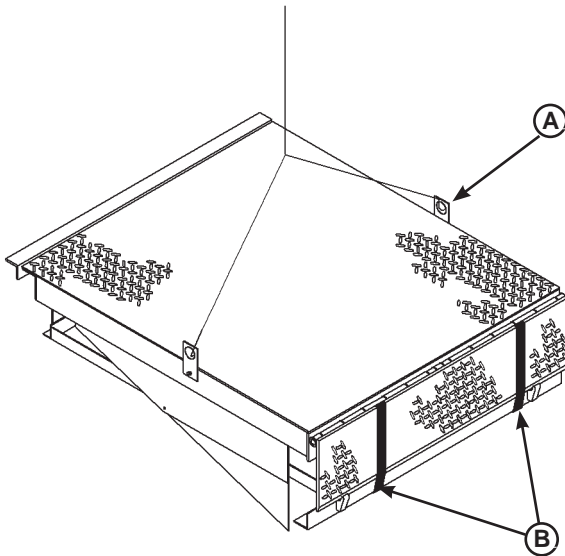

A— Lifting Bracket (2 used)

B — Shipping Bands

Poweramp dock levelers are designed with installation in mind. Each unit is shipped with lifting brackets (A) fastened to the platform side joists.

WARNING

The dock leveler is heavy. Use a lifting device and chains with the appropriate lifting capacity and reach.

Always use the lifting brackets provided with the unit whenever lowering or lifting a dock leveler into or out of a pit.

Failure to follow these instructions may result in damage to dock leveler and/or serious personal injury or death.

IMPORTANT

DO NOT remove the shipping bands (B) around the platform lip and leveler frame at this time. The shipping bands are needed to hold the leveler together during the installation process.

1. Remove any control panel and bumpers that may be banded to the frame of the dock leveler. DO NOT remove the shipping bands (B) around the platform lip and leveler frame at this time.

IMPORTANT

DO NOT overtighten the lifting bracket hardware. Overtightening can damage the weather seal, if equipped.

NOTE: Overall width of platform and lifting brackets (A) must be kept to a minimum to prevent interference between the lifting brackets and the pit walls as the dock leveler is lowered into the pit.

2. Make sure the mounting hardware of lifting brackets (A) is snug. The brackets should pivot relatively freely on the mounting cap screw. DO NOT overtighten.
3. Attach lifting chains to lifting brackets (A) and to a lifting device (i.e., hoist or fork truck) having the appropriate lifting capacity and reach.
4. Remove wood blocks that are attached to the leveler frame before putting the dock leveler into the pit.

INSTALLATION

Install Dock Leveler

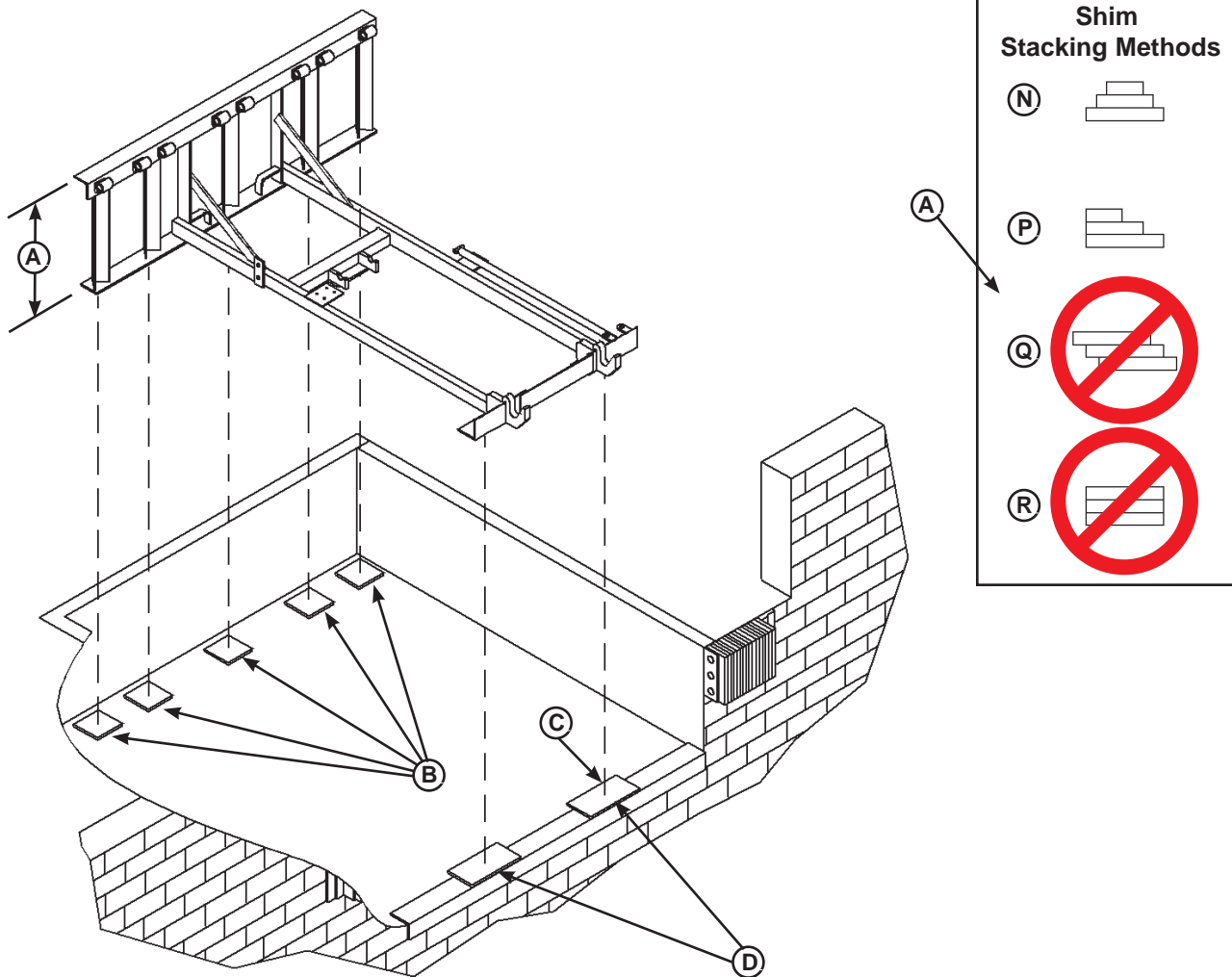

- A— Distance (Leveler Frame Height)
- B— Shim Locations (Under Rear Vertical Supports)
- C— Shim Location (Under Maintenance Prop)
*Same as (D)
- D— Shim Locations (Under Lip Keepers)
- E— Dock Floor
- F— Rear Pit Curb Angle
- G— String
- H— Rear Hinge Frame Angle
- J— Distance (Dock Floor-to-Pit Floor)
- K— Distance (Top of Shim Stack-to-Dock Floor)
- L— Shim Stack
- M— Dock Leveler Frame
- N— Pyramid (Preferred)
- P— Stepped (Acceptable)
- Q— Offset (Not Acceptable)
- R— Straight (Not Acceptable)

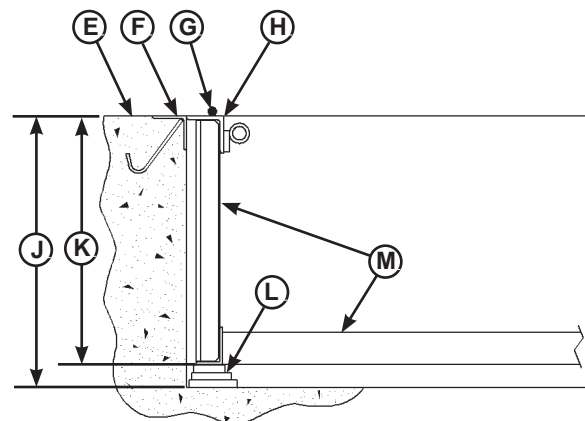

NOTE: Poweramp dock levelers are designed with a nominal 1/2 in. (12.7 mm) shimming distance to allow for pit inconsistencies.

1. Determine height of shim stack (L) for each shim location (B) by performing the following:
 - a. Measure leveler frame height distance (A).
 - b. Measure dock floor-to-pit floor distance (J) at each shim location (B). Write down the dimensions obtained at each location.
 - c. Subtract distance (A) from distance (J) to obtain the shim height. Repeat for each shim location.

IMPORTANT

The minimum size of the shim that contacts the leveler frame (i.e., the top shim of each shim stack) must be at least 4-1/2 x 4-1/2 in. (114.3 x 114.3 mm) to support the full width of the frame rail and to provide a shelf for a fillet weld.

Use the thickest shim stock possible for stability and weld penetration purposes. DO NOT use multiple layers of 1/8 in. (3.18 mm) or thinner shim stock.

2. Using the results obtained in step 1, create the individual shim stacks on the pit floor at locations (B). Build each shim stack (L) using the pyramid method (N) (preferred) or stepped method (P) with the top shim having a minimum size of 4-1/2 x 4-1/2 in. (114.3 x 114.3 mm) and each successive lower shim being larger so the shims can be welded together using a fillet weld. DO NOT use offset method (Q) or straight method (R).

NOTE: To assist in obtaining an accurate measurement of distance (K), use a string (G) pulled tight across the pit opening, directly over the shim locations.

3. Verify that each shim stack is at the correct height by measuring distance (K) [top of shim stack (L) to dock floor]. Distance (K) must equal the dock leveler height (A).

4. For all VH models, put a 1/4 in. (6.6 mm) thick shim at locations (C and D) .

NOTE: A 1/4 in. (6.6 mm) thick shim at locations (C and D) is used only as a starting point. The final shim stack height will be determined after dock leveler is lowered into the pit.



WARNING

The dock leveler is heavy. Use chains and a lifting device with the appropriate lifting capacity and reach. Failure to do so may result in damage to dock leveler and/or serious personal injury or death.

5. Using an appropriate lifting device connected to the lifting brackets, lower dock leveler into the pit so rear hinge frame angle (H) is tight against rear pit curb angle (F) across full width of the leveler frame.
6. Allow rear of dock leveler to rest on the rear shims while keeping the front of the dock leveler level with the dock floor.
7. For all VH models, add shims at front shim locations (C and D) so front of dock leveler will stay level with dock floor when leveler is resting fully on shims.

INSTALLATION

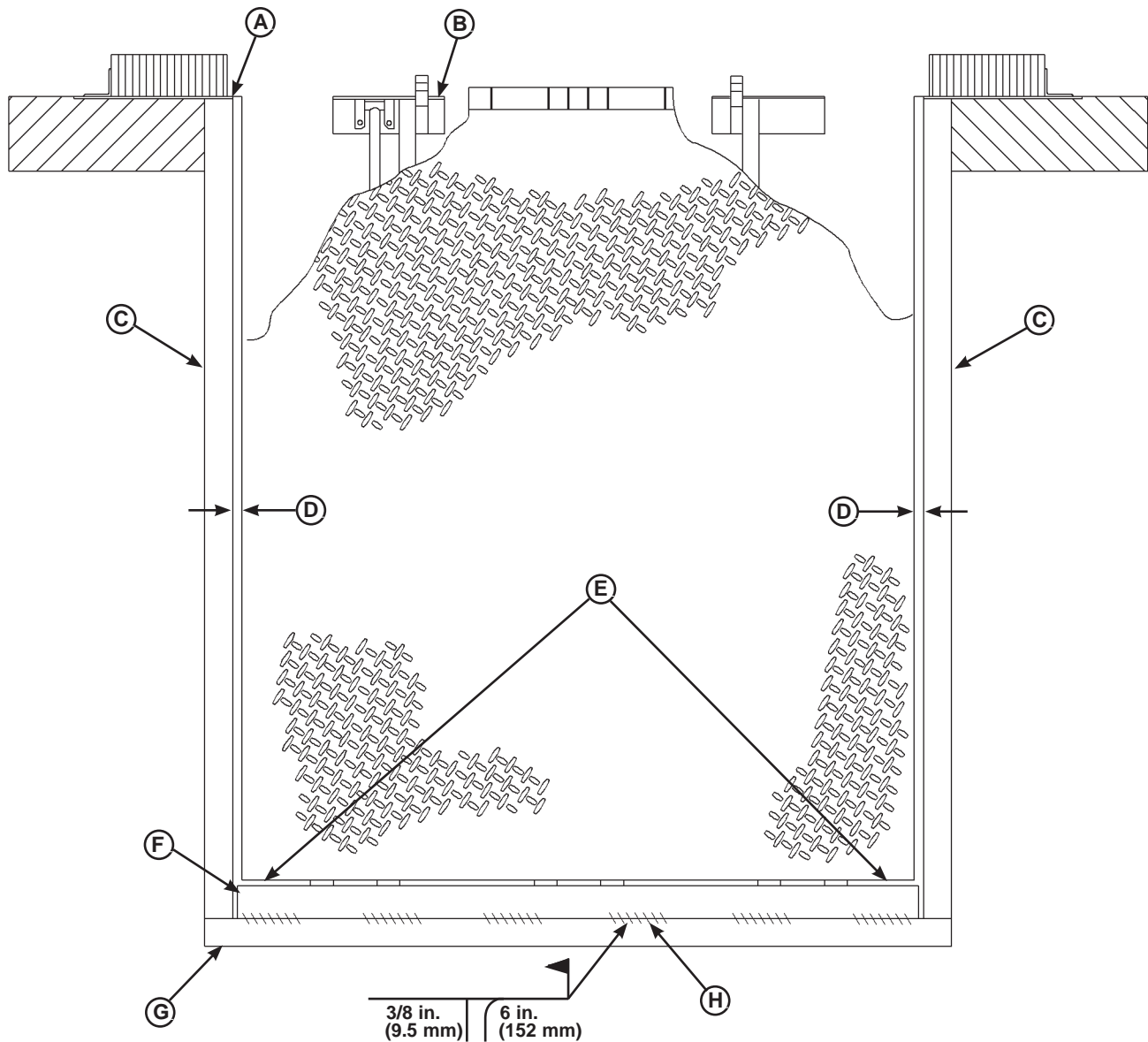

- | | | | |
|-----------------------|----------------------------------|---------------------------|---|
| A— Front of Dock Pit | C— Side Pit Curb Angle | E— Pry Locations | G— Rear Pit Curb Angle |
| B— Dock Leveler Frame | D— Gap [3/4 in. (19 mm) Minimum] | F— Rear Hinge Frame Angle | H— Flare Bevel Weld, Typical (To Fit Spacing) |

8. With rear hinge frame angle (F) tight against rear pit curb angle (G), perform/check the following:
 - Pry between the platform and rear hinge frame angle at locations (E) to make sure rear edge of platform is parallel to the rear hinge frame angle (F).
 - Gap (D) must exist equally along both sides of leveler so weather seal (if equipped) will not bind during dock leveler operation.
9. If gap (D) cannot be obtained equally at both sides of leveler, grind or add material at the rear edge of rear hinge frame angle (F) as needed.
10. Allow the dock leveler to rest fully on the shim stacks. Check that a smooth and level transition exists between the dock floor and the dock leveler platform. Add or remove shims as necessary until a smooth transition is obtained.
11. If leveler cannot be squared and/or made level as instructed in steps 8 — 10, contact Poweramp Technical Services.



WARNING

DO NOT grind or weld if hydraulic fluid or other flammable liquid is present on the surface to be ground or welded.

DO NOT grind or weld if uncontained hydraulic fluid or other flammable liquid is present. Stray sparks can ignite spills or leaks near the work area. Always clean up the oil leaks and spills before proceeding with grinding or welding.

Always keep a fire extinguisher of the proper type nearby when grinding or welding.

Failure to follow these instructions may result in serious personal injury or death.

IMPORTANT

DO NOT connect the dock leveler electrical wiring and ground connections until all welding has been completed.

DO NOT ground welding equipment to any hydraulic or electrical components of the dock leveler. Always ground welding equipment to the dock leveler frame, NEVER to the platform.

Failure to follow these instructions may damage the motor, hoist cylinder, wiring, and/or control panel.

NOTE: The illustration on the previous page shows a typical weld pattern. The weld pattern will vary slightly depending on size of dock leveler.

IMPORTANT

DO NOT weld continuously along the full length of the rear hinge frame angle. This can put unnecessary stress on the leveler components, causing the leveler to malfunction and shorten the lifespan of the affected components.

11. With the rear hinge frame angle (F) tight against the rear pit curb angle (G), weld the rear hinge frame angle (F) to the rear pit curb angle (G) using a 3/8 in. (9.5 mm) flare bevel skip weld — each weld being 6 in. (152 mm) long.

Start at each end with a 6 in. (152 mm) long weld. Space all the other welds out evenly leaving approximately 6 in. (152 mm) space between each weld.

12. Weld front of dock leveler frame (B) to shims located under the keepers, then weld the shims to the front pit curb steel.
13. With leveler welded into place, remove the shipping bands from around lip and leveler frame.



WARNING

If the platform is raised using an external lifting device or the hydraulic system is opened to atmosphere, air will enter into the hydraulic system.

Whenever this happens, always cycle the leveler at least 4 times using the leveler's own hydraulic power system before allowing the leveler to be put into service. This is to make sure all air is purged from the hydraulic cylinders. Failure to do this may result in serious personal injury or death.

INSTALLATION

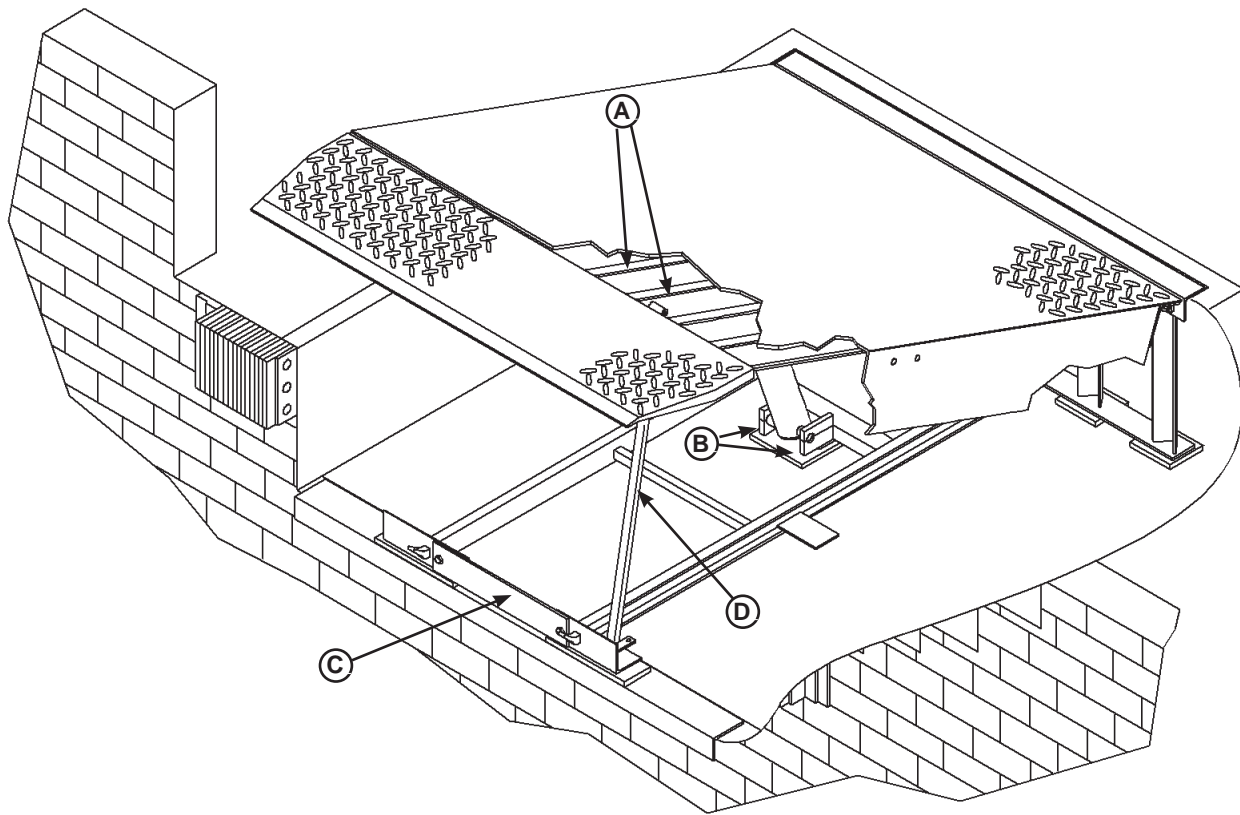

A— Platform Joists
B— Shim Locations (Under Platform Cylinder Trunnions)

C— Removable Frame Section
D— Maintenance Prop

14. Using an external lifting device (i.e., crane or fork truck) attached to the platform lifting brackets, slowly raise the platform. Check for binding as platform is being raised.
15. If binding occurs, lower the platform. Reposition leveler and/or add or remove shims as necessary. Slowly raise platform again. If platform still binds, contact Poweramp Technical Services for further instructions.
16. All VH models:
 - a. Install shims under maintenance prop (D) where prop attaches to leveler frame. Make sure prop is solidly shimmed.
 - b. Using the appropriate lifting device, attached to the platform lifting lugs, slowly raise the dock to the fully open position.

CAUTION

Two people are required to engage the maintenance prop: one person to operate the lifting device, the other person to engage the maintenance prop.

WARNING

DO NOT use the maintenance prop to support the raised platform until the maintenance prop has been properly shimmed and welded. The shims must be welded to each other, the leveler frame, and to the front pit curb steel. Failure to do this may result in serious personal injury or death.

- c. Raise maintenance prop (D) to the service (upright) position and lock prop in this position using an OSHA approved locking device.
- d. Proceed to step 18.



WARNING

Make sure the platform is properly supported in the raised position before entering the pit to finish weld the shims. Failure to do this may result in serious personal injury or death.

18. All model levelers: Install shims at locations (B) using the pyramid or stepped shimming method. Both platform cylinder trunnions must be solidly shimmed the entire length of the trunnion. Make sure the trunnions are level from side-to-side as well as from front-to-back.
19. Finish weld all shims using a fillet weld.
 - Weld all shims within each shim stack to each other, then weld the shim stack to the leveler frame.
 - Weld the front leveler frame shim stacks to the front pit curb steel.

20. When all welding has been completed, paint all the welds and shims.

NOTE: VH models are shipped with a front frame section (C) installed. This temporary frame holds the leveler frame at the correct dimensions until the leveler is permanently anchored into place. Only then should it be removed.

There are four cap screws and nuts that fasten the T-frame to the rest of the leveler frame. Tack welds may also be used.

21. For all VH models, remove the Shipping Bar (C) by grinding the tack welds that hold it in place during transport. Paint after.

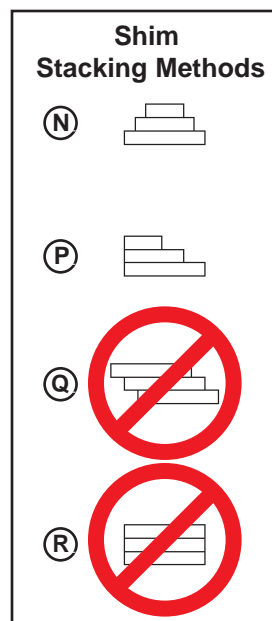

* For left/right orientation of dock leveler, see inside back cover of this manual.

INSTALLATION

Install Control Panel and Wiring

WARNING

The electrical power must be OFF prior to electrical installation. For maximum protection, use an OSHA approved locking device to lock out all power sources. Only the person installing the equipment should have the key to unlock the power source.

Failure to follow these instructions may result in serious personal injury or death.

WARNING

DO NOT make any final electrical connections until all welding has been completed. Failure to do this may result in serious personal injury or death.

CAUTION

All electrical work — including the installation of the disconnect panel, control panel, and final connections to the pit junction box — must be performed by a certified electrician and conform to all local and applicable national codes.

DANGER



Arc Flash and Shock Hazard

PPE (Personal Protection Equipment) Required

De-energize equipment before working on or inside. Do not open cover without appropriate PPE. Refer to NFPA 70E for PPE requirements. This panel may contain more than one power source.

Hazardous Voltage Will Cause Severe Injury or Death

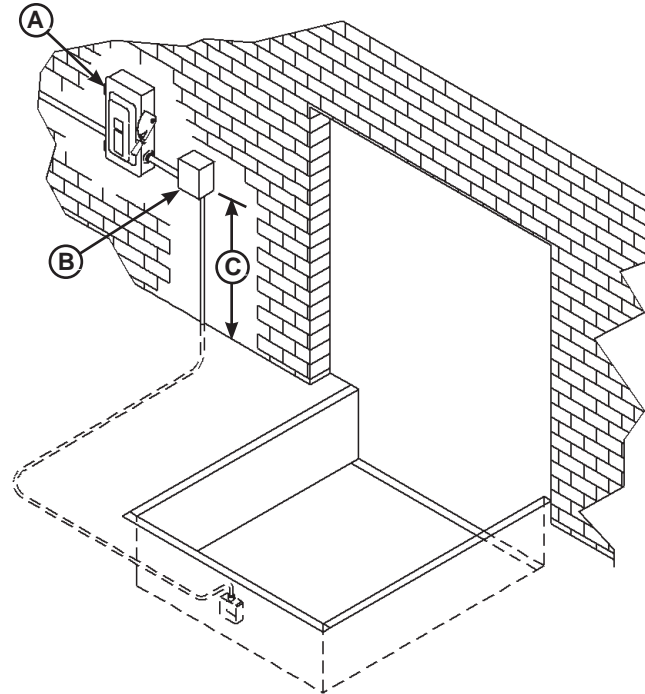

A— Disconnect Panel (provided by others)
B— Control Panel C— Distance, 48 in. (1219.2 mm)

1. Mount the push button control panel (B) so bottom of control panel-to-dock floor distance (C) is 48 in. (1219.2 mm).
2. Install electrical disconnect panel (A) if not already installed.
3. Install and connect the control wiring.
4. Connect the dock leveler power cable to the field wires in the pit junction box. Refer to the electrical drawings supplied with the dock leveler.
5. After all electrical connections in the pit have been made, disengage the maintenance prop and lower the platform using the external lifting device connected to the platform lifting brackets.

Put New Dock Leveler Into Service

1. Disconnect the external lifting device and chains from the lifting brackets.
2. Check that the leveler is flush with the dock floor and that the platform lip contacts both lip keepers evenly.

If an excessive transition exists between the dock floor and leveler and/or lip does not contact both lip keepers evenly, contact Poweramp Technical Services for further instructions.

3. Install the dock bumpers as required.
4. Turn the main electrical power ON.



WARNING

Always stand clear of platform lip when working in front of the dock leveler. Serious personal injury or death may result.

5. Raise the leveler platform fully by pushing and holding the RAISE button .

NOTE: The platform of a properly operating dock leveler will automatically stop rising when it reaches approximately 2 – 3 inches from its full raised height, at which point, the lip extends. When the lip is fully extended, the platform will continue to rise until it reaches the full raised position. (If the lip does not extend or extend fully, see Platform Rises to Full Height, But Lip Does Not Fully Extend in the Troubleshooting section.)

6. Release the RAISE button to lower the platform. As long as there is no truck present at the dock, the platform will lower to the full below-dock position as the lip folds.

NOTE: If a truck is present, the platform will lower until the lip rests on the truck/trailer bed. (See Operating Instructions in Operation section.)

7. When the platform lowers to the full below-dock position, wait 5 seconds after the lip has folded to allow lip cylinder to fully retract. Push and hold the RAISE button until the platform rises just enough to clear the lip keepers, then release the RAISE button to allow the platform to lower to the cross-traffic (stored) position (lip engages lip keepers).

NOTE: For dock levelers equipped with the Auto Return To Dock (ARTD), the platform will automatically return to the cross-traffic position if the ARTD is enabled. When the platform is at the full below-dock position, there is a six-second delay before the platform will automatically rise to the cross-traffic position.

8. Perform steps 5 – 7 at least four times to purge any air that may be in the hydraulic system and to ensure proper operation.



CAUTION

Unless the dock leveler is equipped with a tethered remote, two people are required to engage the maintenance prop: one person to operate the unit, the other person to engage the maintenance prop.

9. Raise the platform fully. Hold the platform at this position using the RAISE button and move the maintenance prop to the service (upright) position. Release the RAISE button to allow the platform to lower until it is resting on the maintenance prop.
10. With the maintenance prop supporting the platform, remove the lifting brackets and front shipping bar in between lip keepers.
11. If equipped with vertical weather seals, position the seals so that the seals are directly under and aligned with the overhead door.
12. Push and hold the RAISE button until the maintenance prop drops to its stored position. Release the RAISE button and allow the platform to lower fully.
13. Perform step 7 if not equipped with ARTD.

OPERATION

Operating Instructions

DANGER

Stay clear of dock leveler when freight carrier is entering or leaving dock area.

DO NOT move or use the dock leveler if anyone is under or in front of leveler.

Keep hands and feet clear of pinch points. Avoid putting any part of your body near moving parts.

Failure to follow these instructions may result in severe personal injury or death.

WARNING

Only trained personnel should operate the dock leveler.

DO NOT use a broken or damaged dock leveler. Make sure proper service and maintenance procedures have been performed on leveler before using.

Truck/trailer wheels must be chocked unless the truck restraint is used. Never remove the wheel chocks until loading/unloading is finished and truck driver has been given permission to leave.

Make sure platform lip rests on the truck/trailer bed with at least 4 in. (102 mm) of overlap.

Maintain a safe distance from side edges of leveler during the loading/unloading process.

Failure to follow these instructions may result in serious personal injury or death.

WARNING

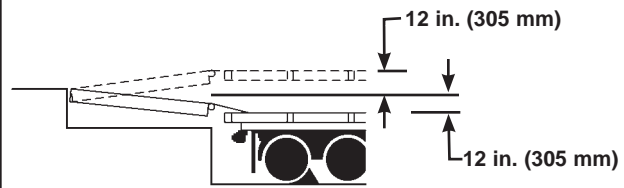

The VH hydraulic dock leveler is designed to compensate for a maximum ± 12 in.* (305 mm) of height difference between the loading dock and the truck bed. DO NOT use the dock leveler if the truck/trailer bed is more than 12 in. (305 mm) higher or lower than the dock floor.

*service height may vary with design specifications

DO NOT overload the dock leveler.

DO NOT operate any equipment while under the influence of alcohol or drugs.

DO NOT leave equipment or material unattended on the dock leveler.

Failure to follow these instructions may result in personal injury and/or damage to equipment.

The dock leveler operating instructions are divided into the two methods of loading and unloading:

- For ramp loading and unloading, see Ramp Loading/Unloading Instructions on page 21.
- For end loading and unloading, see End Loading/Unloading Instructions on page 22.

Operating Instructions—Continued

Ramp Loading/Unloading Instructions

NOTE: If end unloading is required, see End Loading/Unloading Instructions on page 22.

For ramp loading or unloading, the VH dock leveler can be operated by using the RAISE button on the control panel.

1. Check to make sure truck/trailer is positioned squarely against dock bumpers.
2. Instruct driver to remain at the dock until the loading or unloading process has been completed.
3. Chock the truck/trailer wheels or use the truck restraint if available.

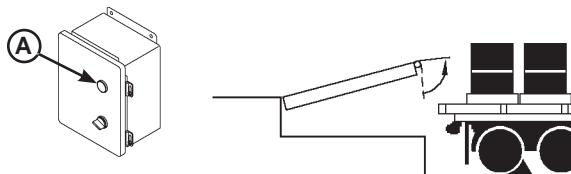

A—RAISE Button

4. Extend the platform lip onto truck/trailer as follows:
 - a. Raise the platform by pushing and holding RAISE button (A).
 - b. Hold the RAISE button until the lip is fully extended, then release the RAISE button. The platform will lower until the lip is resting on the truck/trailer bed.
 - c. Make sure that the lip is fully extended and supported on the truck/trailer along the entire width of the platform with at least 4 in. (102 mm) of lip contacting the truck bed.



5. Proceed with loading or unloading the truck/trailer.
6. If end loading is necessary, see End Loading/Unloading Instructions on page 22.

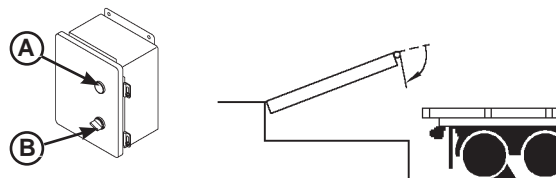

A—RAISE Button

B—ARTD Switch

7. When loading or unloading is finished, raise the platform by pushing and holding RAISE button (A).

Hold the RAISE button until the lip folds enough to clear the truck/trailer bed, then release the RAISE button. The lip will fold and the platform will return to the cross-traffic position.

8. Remove chocks from truck/trailer wheels or release the truck restraint if used.
9. Indicate to driver that truck may leave the dock.

OPERATION

Operating Instructions—Continued

End Loading/Unloading Instructions

NOTE: If ramp loading is required, see Ramp Loading/Unloading Instructions on page 20.

End loading or unloading can be done with the dock at the cross-traffic position or below-dock position, depending on the height of the truck/trailer bed.

1. Check to make sure truck/trailer is positioned squarely against dock bumpers.
2. Instruct driver to remain at the dock until the loading or unloading process has been completed.
3. Chock the truck/trailer wheels or use the truck restraint if available.

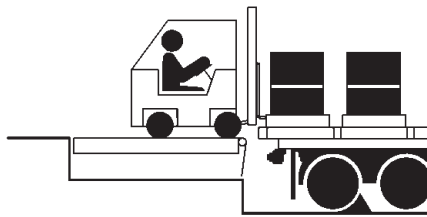

End Loading/Unloading — Platform at Cross-Traffic Position.

4. If truck/trailer bed is at or above dock floor level, leave leveler at the cross-traffic position and proceed with loading or unloading.

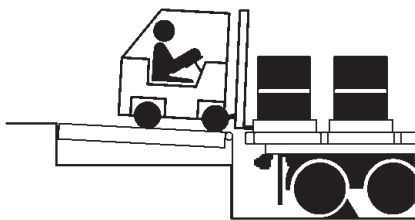

End Loading/Unloading — Platform at Below-Dock Position.

5. If truck/trailer bed is below the dock floor level, and the dock is equipped with the optional lip-out button, perform steps 6–12.

CAUTION

Whenever end loading or unloading with the platform in the below-dock position, make sure the ARTD switch is in the OFF position. DO NOT turn the ARTD switch to the ON position until end loading or unloading is finished.

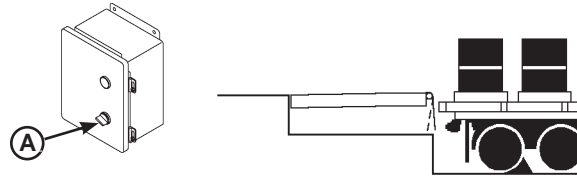

A—ARTD Switch

6. Turn the ARTD switch (A) on the control panel to the OFF position, if equipped.
7. Push the Raise button (B) to the platform just enough to clear the lip keepers.
8. When the platform lip clears the lip keepers, push the Lip-Out button (C) just long enough to clear the lip keepers. Release Lip-Out button. The platform will drift down to the full below-dock position.
9. Proceed with loading or unloading.

NOTE: When end unloading is finished and access to the rest of the truck/trailer is still required, the platform lip will need to be extended. See Ramp Loading/Unloading Instructions on page 19 for further instructions.

10. When the loading or unloading is finished, return the dock leveler platform to the cross-traffic (stored) position by performing one of the following:

- Turn the ARTD switch (A) to the ON position, if equipped. After approximately six seconds, the platform will automatically rise to the cross-traffic position.

OR

- Push the Raise button (B) until the lip clears the lip keepers. Release Raise button, leveler will return to the stored or cross traffic position.
11. Remove chocks from truck/trailer wheels or release the truck restraint if used.
 12. Indicate to the driver that the truck may leave the dock.

Service Dock Leveler Safely

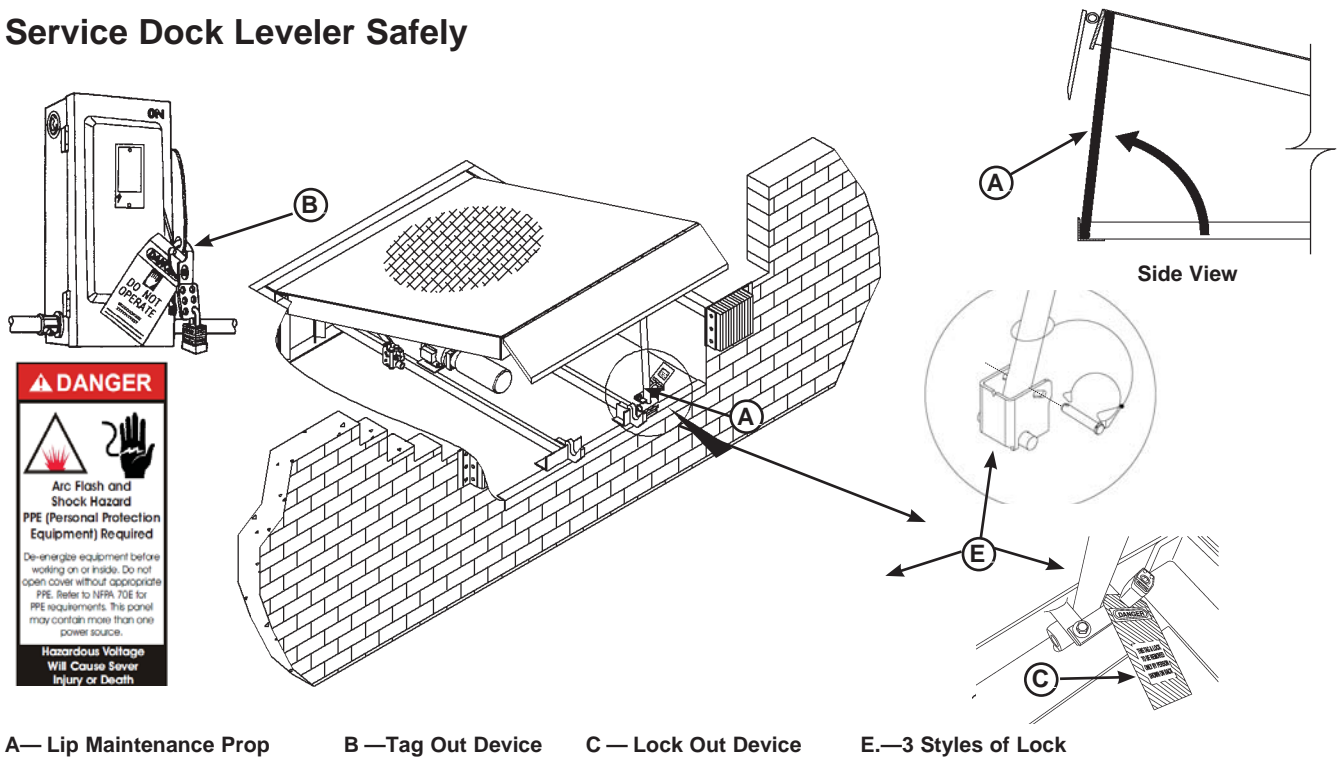

A— Lip Maintenance Prop

B—Tag Out Device

C— Lock Out Device

E.—3 Styles of Lock

⚠ WARNING

When service under the dock leveler is required, always lock all electrical disconnects in the OFF position after raising the platform and engaging the maintenance prop. Failure to do this may result in serious personal injury or death.

⚠ WARNING

Always post safety warnings and barricade the work area at dock level and ground level to prevent unauthorized use of the dock leveler before maintenance is complete. Failure to do this may result in serious personal injury or death.

⚠ WARNING

Always stand clear of the dock leveler lip when working in front of the dock leveler.

The maintenance prop **MUST** be in the service position when working under the dock leveler. For maximum protection, use an OSHA approved locking device to lock the maintenance prop in the service position. Only the person servicing the equipment should have the key to unlock the maintenance prop.

Unless the dock leveler is equipped with a tethered remote, two people are required to engage the maintenance prop: one person to operate the unit, the other person to engage the maintenance prop.

Failure to follow these instructions may result in serious personal injury or death.

Whenever maintenance is to be performed under the dock leveler platform, support the platform with maintenance prop (E). Position the maintenance prop behind front header plate (F) while staying clear of the lip. The lip will fold down after the platform has rested on the maintenance prop. Lock the maintenance prop in the service (upright) position using an OSHA approved lockout device* (C) and tagout device* (D).

Whenever servicing the dock leveler, lock the electrical power disconnect in the OFF position. Use only an OSHA approved lockout device* (B) and tagout device (A).

Only the person servicing the equipment should have the capability to remove the lockout devices. The tagout devices* must inform that repairs are in process and clearly state who is responsible for the lockout condition.

* Refer to OSHA regulation 1910.147.

MAINTENANCE

Periodic Maintenance

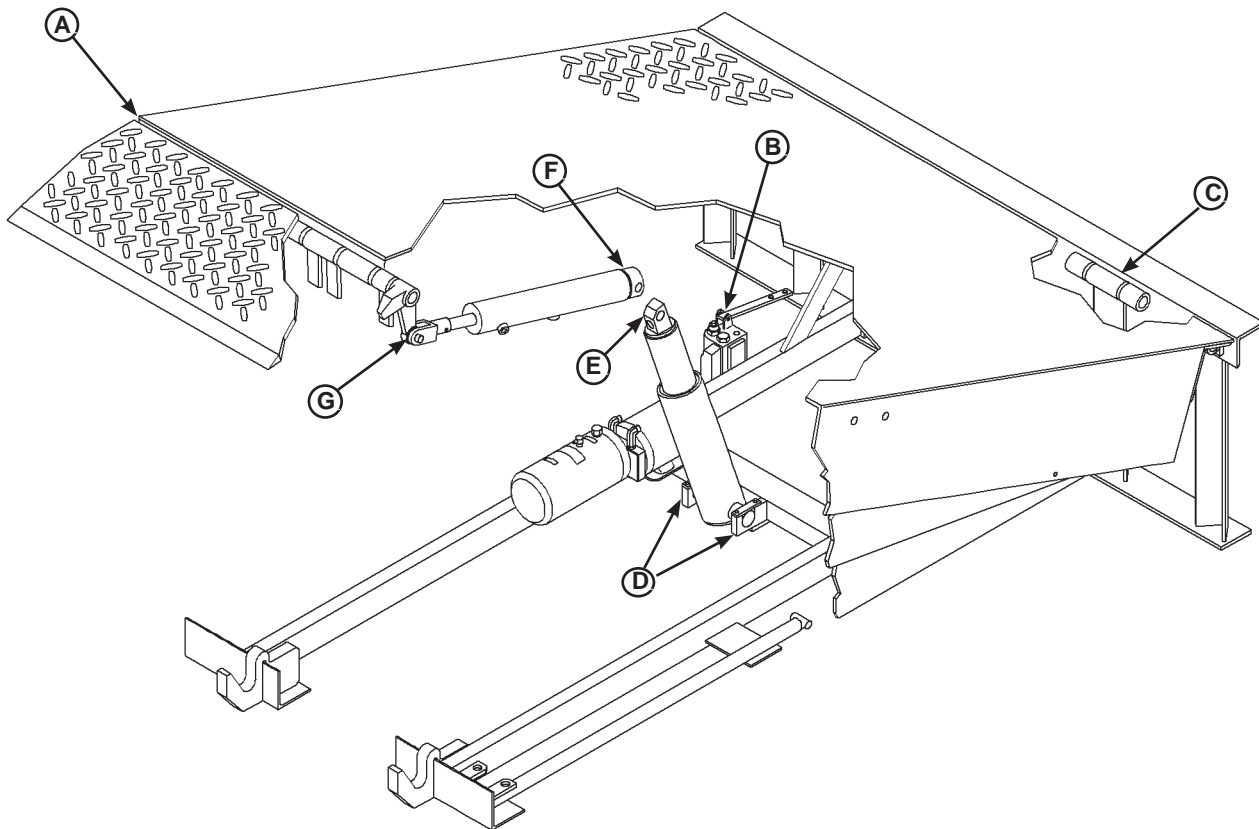

A— Lip Hinge Area

C— Platform Hinge Area

E— Platform Cylinder-to-Platform Pin

G— Lip Lifter and Lift

B— Valve Lever Pivot on Logic
Block

D— Platform Cylinder Trunnion

F— Lip Cylinder-to-Platform Frame Pin

Cylinder Pin



WARNING

Before performing any maintenance under the dock leveler, lock the electrical power source in OFF position and lock the maintenance prop in the service position using an approved locking device. (See Service Dock Leveler Safely in this section.)

Failure to follow these instructions may result in serious personal injury or death.

To ensure normal operation of the dock leveler, use only aircraft hydraulic fluid designed to meet or exceed military specification MIL-H-5606. It is recommended that the following hydraulic fluids be used:

- ULTRA-VIS-HVI-15
- Aero Shell Fluid 4 or Fluid 41
- Mobile Aero HFA Mil-HS606A or Aero HF
- Texaco Aircraft Hydraulic Oil 15 or 5606
- Exxon Univis J13

IMPORTANT

Use of fluids that do not have equivalent specifications to those in the following list will result in abnormal operation of the dock leveler and voiding of warranty.

These fluid brands can be mixed together. Mixing with fluids that do not meet or exceed MIL-H-5606G may damage the equipment and WILL void warranty. Use of hydraulic fluids with equivalent specifications to those listed here are acceptable.

Regular maintenance must be performed on a weekly and quarterly schedule.

Weekly Maintenance

- Operate the dock leveler through the complete operating cycle to maintain lubrication.

NOTE: To thoroughly inspect the platform hinge area, put the platform in the full below-dock position.

- Inspect the platform hinge and the lip hinge areas. The hinge areas must be kept free of dirt and debris. Build-up of foreign material in the hinge areas will cause abnormal operation.

Quarterly Maintenance

IMPORTANT

Failure to properly lubricate the dock leveler will cause abnormal operation of the leveler.

- Lubricate the following areas with light weight machine oil:
 - (A)— Lip hinge area unless equipped with grease fittings (apply oil to the top of the entire length of lip hinge when platform is at the full below-dock position and lip is folded)
 - (C)— Platform hinge area (apply oil to top of all platform hinges when platform is at the full below-dock position)
 - (E)— Platform cylinder-to-platform frame pin
 - (F)— Lip cylinder-to-platform frame pin
 - (G)— Lip lifter and lift cylinder pin
- Lubricate the following areas with white lithium grease:
 - (B)— Valve lever pivot and top of logic block spool valve.
 - (D)— All platform cylinder trunnions

NOTE: Apply grease to lip hinge grease fittings if equipped.

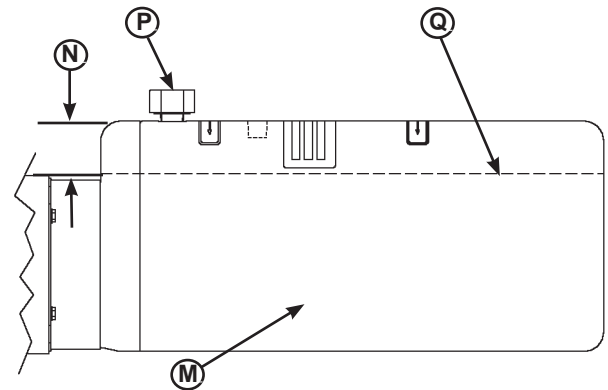

M - Reservoir

P - Breather Cap

N- 3 in. (76.5mm) From Top of Reservoir

Q - Fluid Level

IMPORTANT

A low fluid level or the use of hydraulic fluids not equivalent to the fluid types recommended, will cause abnormal operation of the leveler and WILL void warranty.

- Check reservoir fluid level (Q):
 1. Put the dock leveler platform at the full above-dock position.
 2. Turn OFF all electrical power to the leveler.
- ! WARNING**

Before performing any maintenance under the dock leveler, lock the electrical power source in OFF position and lock the maintenance prop in the service position using an approved locking device. (See Service Dock Leveler Safely in this section.)

Failure to follow these instructions may result in serious personal injury or death.
4. Remove breather cap (P).
 5. Measure fluid level. The fluid level should be approximately 3 in. (76.5 mm) (N) from top of reservoir (M) with platform raised on the maintenance prop.
 6. Add hydraulic fluid if necessary. Use only recommended fluid.
 7. Install breather cap and inspection plate.
 8. Turn ON electrical power to the leveler.
 9. Return the platform to the cross-traffic position.

ADJUSTMENTS

Adjust Main Pressure Relief

WARNING

When service under the dock leveler is required, always lock all electrical disconnects in the OFF position after raising the platform and engaging the maintenance prop. Failure to do this may result in serious personal injury or death.

WARNING

Always post safety warnings and barricade the work area at dock level and ground level to prevent unauthorized use of the dock leveler before maintenance is complete. Failure to do this may result in serious personal injury or death.

WARNING

Always stand clear of the dock leveler lip when working in front of the dock leveler.

The maintenance prop **MUST** be in the service position when working under the dock leveler. For maximum protection, use an OSHA approved locking device to lock the maintenance prop in the service position. Only the person servicing the equipment should have the key to unlock the maintenance prop.

Unless the dock leveler is equipped with a tethered remote, two people are required to engage the maintenance prop: one person to operate the unit, the other person to engage the maintenance prop.

Failure to follow these instructions may result in serious personal injury or death.

NOTE: *The main pressure relief may need to be increased if the platform does not rise or rises slowly and the system operates in pressure relief mode. See Troubleshooting section.*

The main pressure relief may need to be decreased if the pump motor loads down when platform reaches the full raised position. See Troubleshooting section.

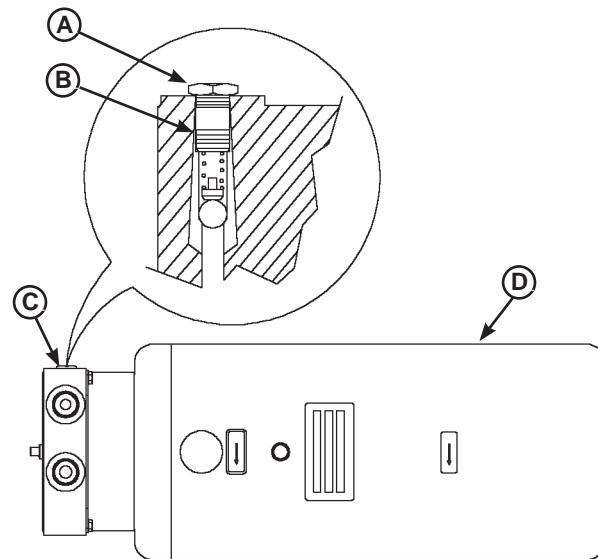

A— SAE Cap Screw C— Main Pressure Relief
B— Hex Adjusting Screw D—Reservoir

To adjust the main pressure relief:

1. Raise the platform fully and engage the maintenance prop in the service position.
2. Turn OFF all electrical power to the dock leveler. Attach safety lockout and tagout devices.
3. Remove SAE plug (A).
4. Adjust hex adjusting screw (B) in small 1/4 turn increments as follows:
 - Turn clockwise to increase pressure relief.
 - Turn counterclockwise to decrease pressure relief.
5. Tighten the jam nut and install the SAE plug.
6. Turn ON electrical power to the dock leveler.
7. Disengage the maintenance prop.
8. Check leveler operation.
9. Repeat steps 1– 8 as necessary.

Adjust Cable Weight and Down Speed Control

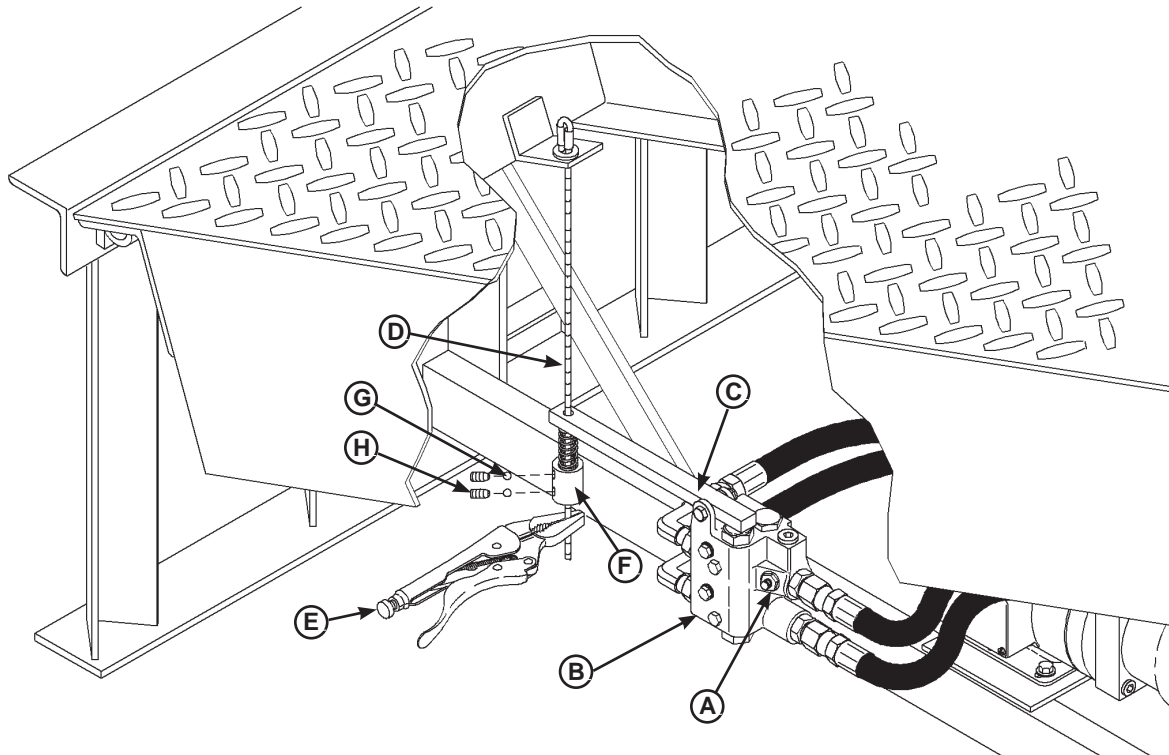

A— Speed Control Adjusting Screw
B— Logic Block

C— Valve Lever
D— Cable

E— Locking Pliers
F— Cable Weight

G— Steel Ball (2 used)
H— Set Screw (2 used)

Cable Weight Adjustment

If the platform lip does not extend, or extends too soon, cable weight (F) may need adjustment. The cable weight is attached to cable (D) and is located underneath the platform, directly behind logic block (B).

The factory setting causes the lip to fully extend when 1 – 3 in. (25.4 – 76.2 mm) of travel is left in the platform cylinder.

NOTE: To prevent the cable weight from accidentally falling off the cable when adjusting the weight, attach a locking pliers or similar device to the cable just below the cable weight. If adjustment requires that the weight be moved down, allow sufficient distance between pliers and weight before adjusting.

To adjust the cable weight:

- Loosen (do not remove) set screws (H). If set screws are removed, balls (G) may fall out.
- To make lip extend sooner, slide the weight up.
- To make lip extend later, slide the weight down.
- Tighten set screws.

Down Speed Control Adjustment

If the dock leveler did not lower, it is possible that the speed control requires adjustment. The speed control adjusting screw (A) is a hex screw located in logic block (B), directly behind the upper front hose connection.

NOTE: If the platform lowers too fast, the platform will stop lowering and lock in “safety” mode.

Use 1/4 turn increments when adjusting the down speed control. Check platform lowering speed after each adjustment.

To adjust the speed control:

- Loosen the jam nut.
- To decrease the lowering speed, turn adjusting screw (A) clockwise.
- To increase the lowering speed, turn adjusting screw (A) counterclockwise.
- Tighten the jam nut.

NOTE: Extreme cold and/or incorrect fluid may also cause cylinder to lock. Adjust downspeed to decrease lowering speed.

ADJUSTMENTS

Adjust Auto Return To Dock (ARTD)

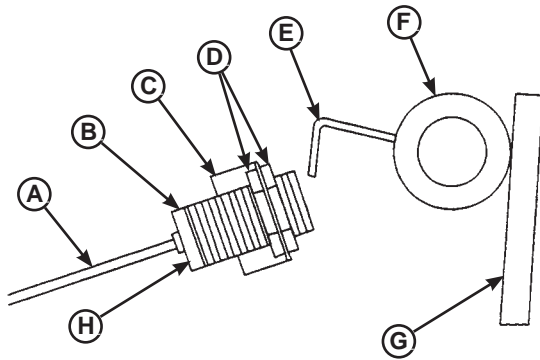

- | | |
|---------------------|--------------------|
| A— Cable | E— Target |
| B— Proximity Switch | F— Lip Hinge Tube |
| C— Bracket | G— Platform Lip |
| D— Lock Nuts | H— Indicator Light |

VH levelers are equipped with the optional Auto Return To Dock (ARTD) if leveler not interlocked with a truck restraint.

The ARTD allows the platform to automatically return to the cross-traffic (stored) position after the truck departs. The ARTD uses a proximity switch (B) located under the platform and a piece of angled steel called the target (E) that is attached to the lip hinge tube (F).

The proximity switch provides a six-second delay after the platform has lowered to the full below-dock position, after which, the platform will return to the cross-traffic position. The switch also contains an indicator light (H) that can be used for diagnosing and adjusting the switch.

NOTE: Some proximity switches have an indicator light at the back of the housing and some have the light at the side of the housing.

Adjust the ARTD as Follows:

WARNING

When service under the dock leveler is required, always lock all electrical disconnects in the OFF position after raising the platform and engaging the maintenance prop. Failure to do this may result in serious personal injury or death.

WARNING

Always post safety warnings and barricade the work area at dock level and ground level to prevent unauthorized use of the dock leveler before maintenance is complete. Failure to do this may result in serious personal injury or death.

WARNING

Always stand clear of the dock leveler lip when working in front of the dock leveler.

The maintenance prop MUST be in the service position when working under the dock leveler. For maximum protection, use an OSHA approved locking device to lock the maintenance prop in the service position. Only the person servicing the equipment should have the key to unlock the maintenance prop.

Unless the dock leveler is equipped with a tethered remote, two people are required to engage the maintenance prop: one person to operate the unit, the other person to engage the maintenance prop.

Failure to follow these instructions may result in serious personal injury or death.

1. Raise platform fully and engage the maintenance prop in the service position. Allow platform to rest on the prop so the lip will fully fold until it contacts the lip stops.
2. Turn OFF all electrical power to the dock leveler. Attach safety lockout and tagout devices.

IMPORTANT

Anytime proximity switch and target are adjusted, always check for interference between target and switch before operating the leveler. Damage to switch will occur if the target contacts the switch.

The maximum torque for proximity switch lock nuts is 27 N·m (29 lb-ft). Damage to switch will occur if maximum torque is exceeded.

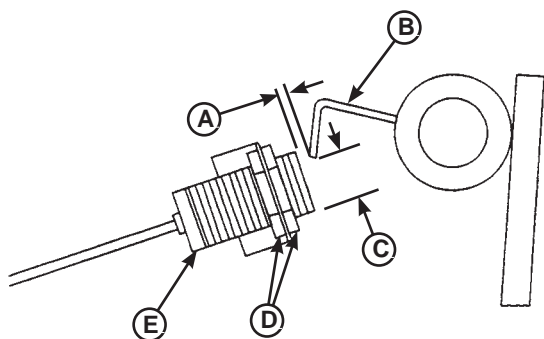

A— 1/4 in. (6.4 mm)
Approximate
B— Target

C— 1 in. (25.4 mm)
Approximate
D— Lock Nuts
E— Proximity Switch

NOTE: Distances (A and C) are typical factory settings. Use these dimensions only as a starting point when adjusting the proximity switch and target, especially if switch and/or target have been replaced.

When dimensions (A and C) are obtained, the proximity switch and target may need finer adjustments to get the ARTD to operate satisfactorily.

3. Loosen lock nuts (D). Adjust proximity switch (E) to obtain distance (A). Tighten lock nuts.
4. Bend target (B) as needed to obtain distance (C). Recheck distance (A) and readjust if necessary.

NOTE: At least two people may be required to manually move the lip.

5. After adjusting proximity switch and target, slowly move the lip up by hand while observing the target and proximity switch. The target **MUST NOT** contact the switch, otherwise, damage to switch will occur. Readjust switch and/or target if necessary, then recheck for interference.

6. Turn ON electrical power to the dock leveler.
7. Disengage the maintenance prop.
8. Turn the ARTD switch (on control panel) to the ON position.
9. Raise the platform until the lip is fully extended, then allow the platform to drift to the below-dock position.

After approximately 6 seconds, the platform must return to the cross-traffic position.

10. Adjust the proximity switch and target as necessary. Make small adjustments, then operate the dock leveler to check results. Do this until satisfied with the ARTD operation.

Use the following illustrations to assist in fine tuning and/or diagnosing the ARTD operation.

Cross-Traffic Position

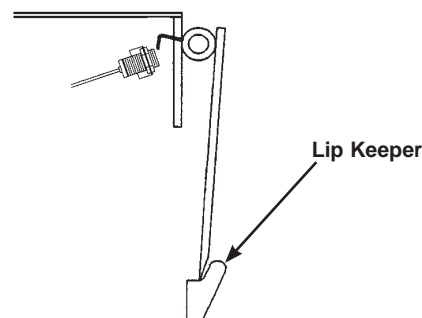

NOTE: The platform lip is fully folded when the platform is at the cross-traffic (stored) position (lip engaged with keepers) or when platform is resting on the maintenance prop.

Whenever the platform lip is at the cross-traffic position, the following conditions will exist for a normally operating ARTD:

- Target not in the sensing area of proximity switch.
- Proximity switch OFF (open) (no signal sent to control panel).
- Proximity switch indicator light is OFF.
- Platform stays at this position unless the operator activates the leveler.

ADJUSTMENTS

Full Below-Dock Position

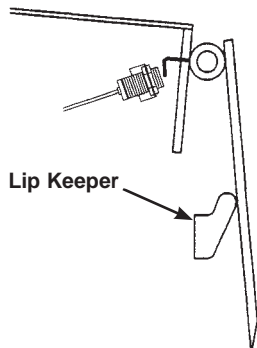

Whenever the platform lip is at the full below-dock position, the following conditions will exist for a normally operating ARTD:

- Proximity switch senses target.
- Proximity switch ON (closed) (signal sent to the control panel).
- Proximity switch indicator light is ON.
- Platform will automatically rise after approximately a six-second delay, then returns to the cross-traffic position.

Lip Fully Extended Position

Whenever the platform lip is at the fully extended position, the following conditions will exist for a normally operating ARTD:

- Target not in the sensing area of proximity switch.
- Proximity switch OFF (open) (no signal sent to the control panel).
- Proximity switch indicator light is OFF.
- If the platform lip is resting on the truck bed, the platform will stay at this position unless the operator activates the leveler.

WARNING

When service under the dock leveler is required, always lock all electrical disconnects in the OFF position after raising the platform and engaging the maintenance prop. Failure to do this may result in serious personal injury or death.

WARNING

Always post safety warnings and barricade the work area at dock level and ground level to prevent unauthorized use of the dock leveler before maintenance is complete. Failure to do this may result in serious personal injury or death.

WARNING

Always stand clear of the dock leveler lip when working in front of the dock leveler.

The maintenance prop **MUST** be in the service position when working under the dock leveler. For maximum protection, use an OSHA approved locking device to lock the maintenance prop in the service position. Only the person servicing the equipment should have the key to unlock the maintenance prop.

Unless the dock leveler is equipped with a tethered remote, two people are required to engage the maintenance prop: one person to operate the unit, the other person to engage the maintenance prop.

Failure to follow these instructions may result in serious personal injury or death.

Before performing the detailed troubleshooting procedures, check the following items first:

- Check all fuses inside the control panel(s). Replace any blown fuse(s) with a fuse of equal specification.
- Make sure the correct voltages are present at the proper locations inside the control panel(s).

Symptom	Possible Cause	Solution
Platform does not rise. Motor does not energize.	Motor overload device tripped or fuse blown.	Reset overload relay (three-phase) or replace fuse(s) (single-phase). Determine cause of overload. <i>NOTE: When replacing fuse(s), the new fuse must have the same specification as the old fuse.</i>
	Motor starter (three-phase) or motor relay (single-phase) not energizing.	Check voltage at starter or relay coil. <ul style="list-style-type: none"> • If voltage is present and starter or relay does not energize, replace starter or relay. • If voltage is not present, check all components in series with the starter or relay coil.

TROUBLESHOOTING

Symptom	Possible Cause	Solution
Three-phase units only: Platform does not rise. Motor hums, but does not run.	No voltage is present on one line.	Check for blown fuses at branch circuit disconnect. Replace fuse. Determine cause of blown fuse.
	<i>NOTE: A motor that is missing voltage on one line is said to be single-phased.</i>	Check motor starter as follows: 1. Disconnect wires at load side of starter. 2. Energize the starter. 3. Measure line-to-line voltage at line side of starter. 4. Measure line-to-line voltage at load side of starter. 5. Line-side and load-side voltages should be approximately the same. Replace starter if voltage values are considerably different from one another.
		Check all wiring to motor for high resistance or no connection.
Three-phase units only: Platform does not rise. Motor runs in reverse	Phase reversed.	Reverse any two legs at the branch circuit disconnect.
Single-phase units only: Platform does not rise. Motor energizes, but does not run.	Line voltage too low.	Check wiring to motor for high resistance. Check for loose or corroded connections. Check if gauge of wires to motor are of correct size and specification for load requirement. Replace if necessary.
	Defective motor centrifugal switch.	Replace motor.
	Defective motor capacitor.	Replace motor.
Dock leveler equipped with ARTD: Platform does not automatically return to the cross-traffic position or operates abnormally.	The auto return proximity switch not sensing target correctly.	Adjust proximity switch and target as necessary. See Adjust Auto Return To Dock (ARTD) in the Adjustment section.
	Defective proximity switch.	Replace switch.
	Broken wire. Loose or corroded wire connections.	Repair or replace wires and connections as necessary.

TROUBLESHOOTING

Symptom	Possible Cause	Solution
Platform does not rise. Pump operates in pressure relief mode.	Heavy object(s) on platform.	Remove object(s) from platform. <i>NOTE:</i> For safety reasons, the dock leveler is designed to lift only the platform's own weight.
	Dock leveler binds.	Check for visible obstructions that could cause binding. Remove obstructions. If no obstructions found, call Poweramp Technical Services. See inside back cover for phone number and address.
	Pressure relief set too low.	Increase pressure relief. See Adjust Main Pressure Relief in the Adjustment section. <i>NOTE:</i> The pressure relief valve must not be set at a level that causes the motor operating current to exceed the full load amp value* at any time, including when operating in pressure relief. <i>* The full load amp value can be found on the inside cover of the control panel.</i>
Platform rises slowly.	Low hydraulic fluid.	Add fluid as needed. See Periodic Maintenance in the Maintenance section.
	Contaminated hydraulic system.	Clean and inspect valves. Flush contaminated oil from hydraulic system. Fill system with new oil. See Periodic Maintenance in the Maintenance section.
	Damaged or restricted hydraulic hose(s).	Replace damaged hose(s). Remove restriction.
	Pressure relief set too low.	Increase pressure relief. See Adjust Main Pressure Relief in the Adjustment section. <i>NOTE:</i> The pressure relief valve must not be set at a level that causes the motor operating current to exceed the full load amp value* at any time, including when operating in pressure relief. <i>* The full load amp value can be found on the inside cover of the control panel.</i>
Pump motor loads down when platform reaches the full raised position.	Pressure relief set too high.	Decrease pressure relief. See Adjust Main Pressure Relief in the Adjustment section. <i>NOTE:</i> The pressure relief valve must not be set at a level that causes the motor operating current to exceed the full load amp value* at any time, including when operating in pressure relief. <i>* The full load amp value can be found on the inside cover of the control panel.</i>

TROUBLESHOOTING

Symptom	Possible Cause	Solution
Platform does not rise to full height.	Low hydraulic fluid.	Add fluid as needed. See Periodic Maintenance in the Maintenance section.
Platform DOES rise to full height, but lip DOES NOT extend or extend fully.	Low hydraulic fluid.	Add fluid as needed. See Periodic Maintenance in the Maintenance section.
	Logic block (valve) lever cable weight too low on cable.	Adjust cable weight. See Adjust Cable Weight and Down Speed Control in the Adjustment section.
Lip does not extend.	Logic block spool valve stuck in the up position or valve lever binding so that the lever will not push the spool down.	Apply penetrating oil to spool area and valve lever pivot at top of logic block. If necessary, disconnect the valve lever from logic block. Move spool valve up and down until spool valve slides freely. If the spool valve cannot be made to slide freely, replace spool valve. Lubricate valve lever pivot with white lithium grease.
Lip extends almost immediately when the RAISE button is pushed. Platform rises after lip is fully extended.	Logic block spool valve stuck in the down position or valve lever binding causing lever to prematurely push the spool down.	Apply penetrating oil to spool area and valve lever pivot at top of logic block. If necessary, disconnect the valve lever from logic block. Move spool valve up and down until spool valve slides freely. If the spool valve cannot be made to slide freely, replace spool valve. Lubricate valve lever pivot with white lithium grease.
Platform locks into "safety" as platform lowers. Lip drops to vertical position.	Platform lowering speed is too fast.	Adjust platform down speed control. See Adjust Cable Weight and Down Speed Control in the Adjustment section. <i>NOTE: Extreme cold weather OR incorrect fluid may cause platform to lock. Adjustment is same.</i>

Controls

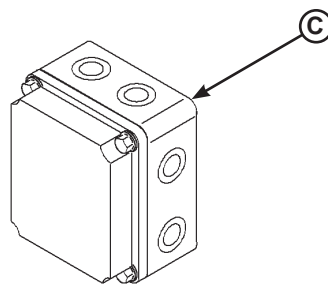
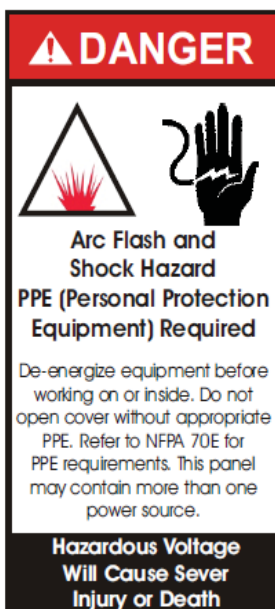
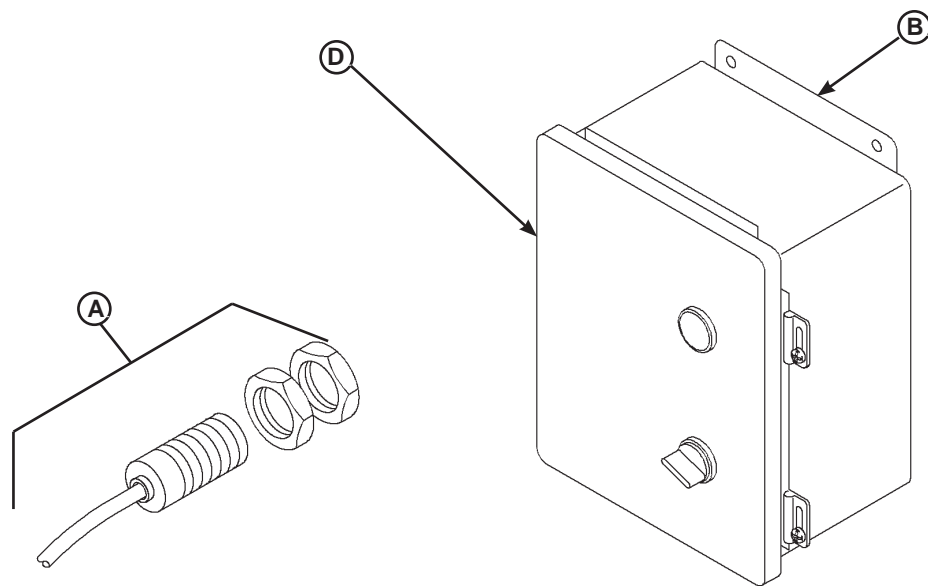

Item	Quantity	Part Number	Description
A	1	0615-0040	Proximity Switch with Harness (ARTD Feature Only)
B	1	*	Push Button Controller
C	1	9511-0004	J-Box, Standard (4 x 4 in. Metal Box)
		9512-0429	J-Box, Cold Weather (5 x 5 in. Plastic Box)
D	1	1751-0736	Decal, Arc Flash

* Provide dock leveler serial number, voltage, phase, and options when calling or faxing controller orders.

PARTS

Frame and Platform

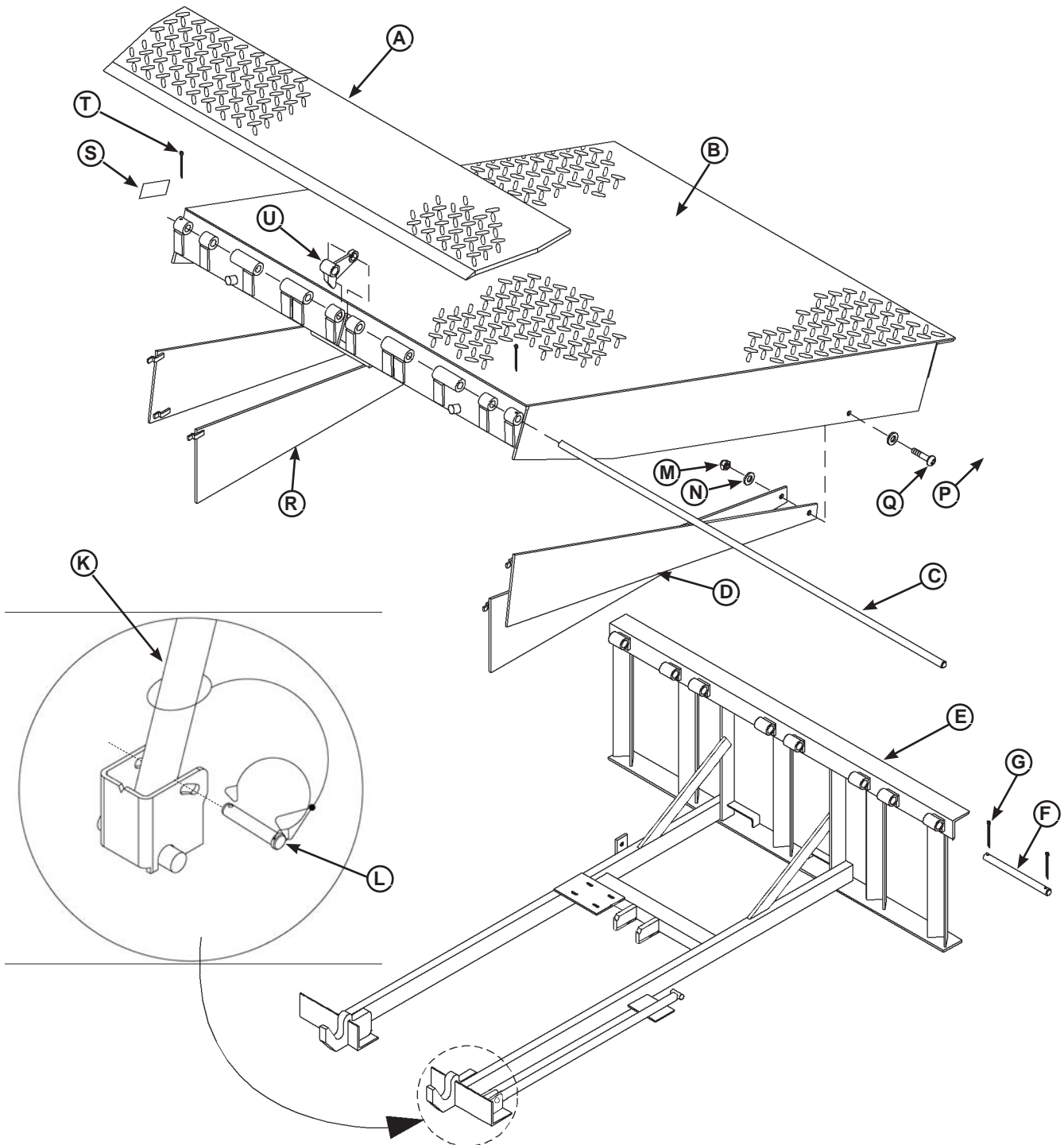

Frame and Platform

Item	Quantity	Part Number	Description
A	1	0595-____ ¹	Lip, Welded Assembly
B	1	7823-____ ²	Platform, Welded Assembly
C	1	9202-0050	Pin, Lip Hinge, 1" Dia 70.50 LG
		9202-0051	Pin, Lip Hinge, 1" Dia 76.75 LG
		9202-0052	Pin, Lip Hinge, 1" Dia 81.50 LG
D	1	0014-0062	Toe Guard Welded Assembly, Left Upper 6 Foot VH3
	1	0014-0066	Toe Guard Welded Assembly, Left Lower 6 Foot VH3
	1	0014-0070	Toe Guard Welded Assembly, Left Upper 8 Foot VH3
	1	0014-0074	Toe Guard Welded Assembly, Left Lower 8 Foot VH3
E	1	0015-____ ¹	Frame, VH
F	3	9202-0002	Rear Hinge Pin
G	6	2101-0047	Cotter Pin, 1/4 x 2 in.
H	1	-	
J	1	-	
K	1	9225-____ ¹	Maintenance Prop Rod
L	1	9201-0001	Prop Pin & Clip
M	AR	2101-0039	Nylon Lock Nut, 5/16-18 UNC
N-P	AR	2101-0163	Washer, 5/16 in., Flat
Q	AR	2101-0011	Cap Screw, 5/16-18 UNC x 1 in.
R	1	0014-0064	Toe Guard Welded Assembly, Right Upper 6 Foot VH3
	1	0014-0068	Toe Guard Welded Assembly, Right Lower 6 Foot VH3
	1	0014-0072	Toe Guard Welded Assembly, Right Upper 8 Foot VH3
	1	0014-0076	Toe Guard Welded Assembly, Right Lower 8 Foot VH3
S	1	1751-0010	Decal, Model/Serial ID
T	2	2101-0046	Cotter Pin, 1/4 x 1-1/4 in.
U	1	0521-0154	Lip Lifter Short
	1	0523-0523	Lip Lifter Long

AR = As Required

¹ Provide dock leveler serial number, platform size, and lip size when calling or faxing orders.

² Provide length and width of inspection plate opening when calling or faxing orders.

* For left/right orientation of dock leveler, see inside back cover of this manual.

PARTS

Hydraulic Components

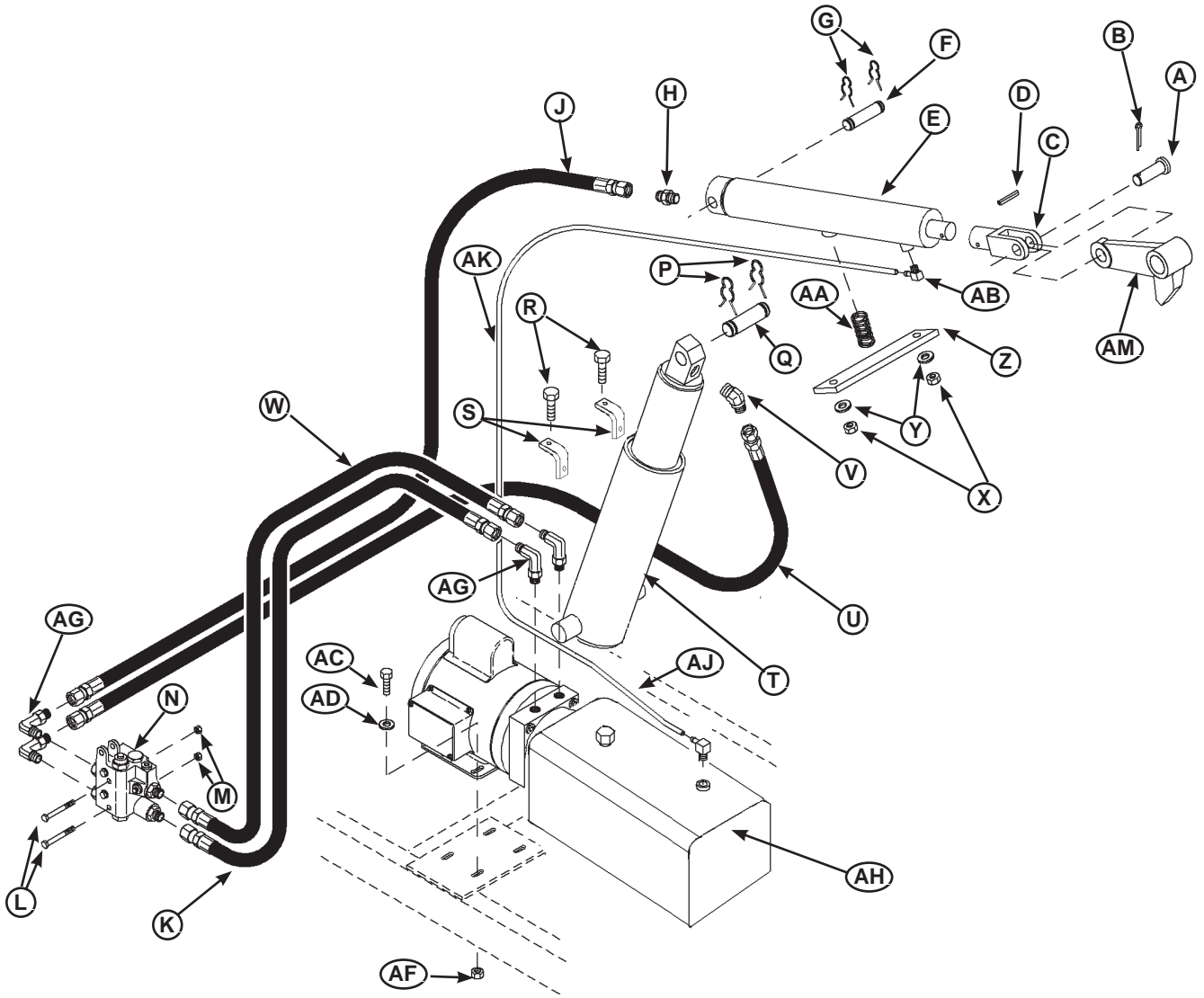

Hydraulic Components

Item	Quantity	Part Number	Description
A	1	0522-0005	Clevis Pin
B	1	2101-0045	Cotter Pin
C	1	0522-0156	Yoke
D	1	0521-0005	Roll Pin
E	1	0525-0086	Lip Cylinder, 13-3/4 in. (349 mm) Barrel Length
		0525-0087	Lip Cylinder, 20-1/8 in. (511 mm) Barrel Length
F	1	9202-0004	Pin, 3/4 x 4.38 in.
G	2	2101-0049	Clip, Hairpin, 5/8 in. dia.
H	1	9301-0111	Fitting, #6-ORB Male x #8-JIC Male
J	1	9904-0074	Hose, Logic Block-to-Lip Cylinder
K	1	9904-0106	Hose, Pump Pressure Port-to-Logic Block
L	2	2101-0015	Cap Screw, 5/16-18 UNC x 3-1/4 in.
M	2	2101-0039	Nylon Lock Nut, 5/16-18 UNC
N	1	9575-0007	Logic Block
	1	9575-0010	Logic Block, Cold Weather
P	2	2101-0050	Clip, Hairpin, 7/8 in. dia.
Q	2	9202-0005	Pin, 1 x 3-3/4 in.
R	4	2101-0009	Cap Screw, 5/16-18 UNC x 3/4 in.
S	2	8431-0022	Platform Cylinder, Hold Down
T	1	0525-0043	Cylinder, Platform, 15-1/2 in. (394 mm) Barrel Length
	1	0525-0044	Cylinder, Platform, 17-1/2 in. (445 mm) Barrel Length
	1	0525-0045	Cylinder, Platform, 19-1/2 in. (495 mm) Barrel Length
	1	0525-0046	Cylinder, Platform, 21-1/2 in. (546 mm) Barrel Length
U	1	9904-0075	Hose, Logic Block-to-Platform Cylinder
V	1	9301-0120	Elbow, 45° #8-ORB Male x #8-JIC Male
W	1	9904-0106	Hose, Logic Block-to-Pump Return Port
X	2	2101-0040	Nylon Lock Nut, 3/8-16 UNC
Y	2	2101-0060	Washer, 3/8 in.
Z	1	9455-____ ²	Hold-Down, Lip Cylinder
AA	1	0522-0002	Spring
AB	1	0521-0007	Elbow, 90° 1/4 NPT Male x 1/4 Tube
AC	4	2101-0011	Cap Screw, 5/16-18 UNC x 1 in.
AD	4	2101-0058	Washer, 5/16
AF	6	2101-0039	Nylon Lock Nut, 5/16-18 UNC in.
AG	1	0521-0016	Elbow, 45° 3/8 NPT Male x #8-JIC Male
AH	1	9395-____ ³	Power Pack Complete
AJ	1	0521-0007	Elbow, 90° 1/4 NPT Male x 1/4 Tube
AK	1	R509-____ ¹	Tube, Vent (3/8 OD x 1/16 in. Wall)
AM	1	0523-____ ²	Lip Lifter

¹ Provide length and diameter of hose when calling or faxing orders.

² Provide length of lip cylinder when calling or faxing orders.

³ Provide dock leveler serial number, voltage, and phase when calling or faxing orders.

PARTS

Platform Cylinder Repair Parts

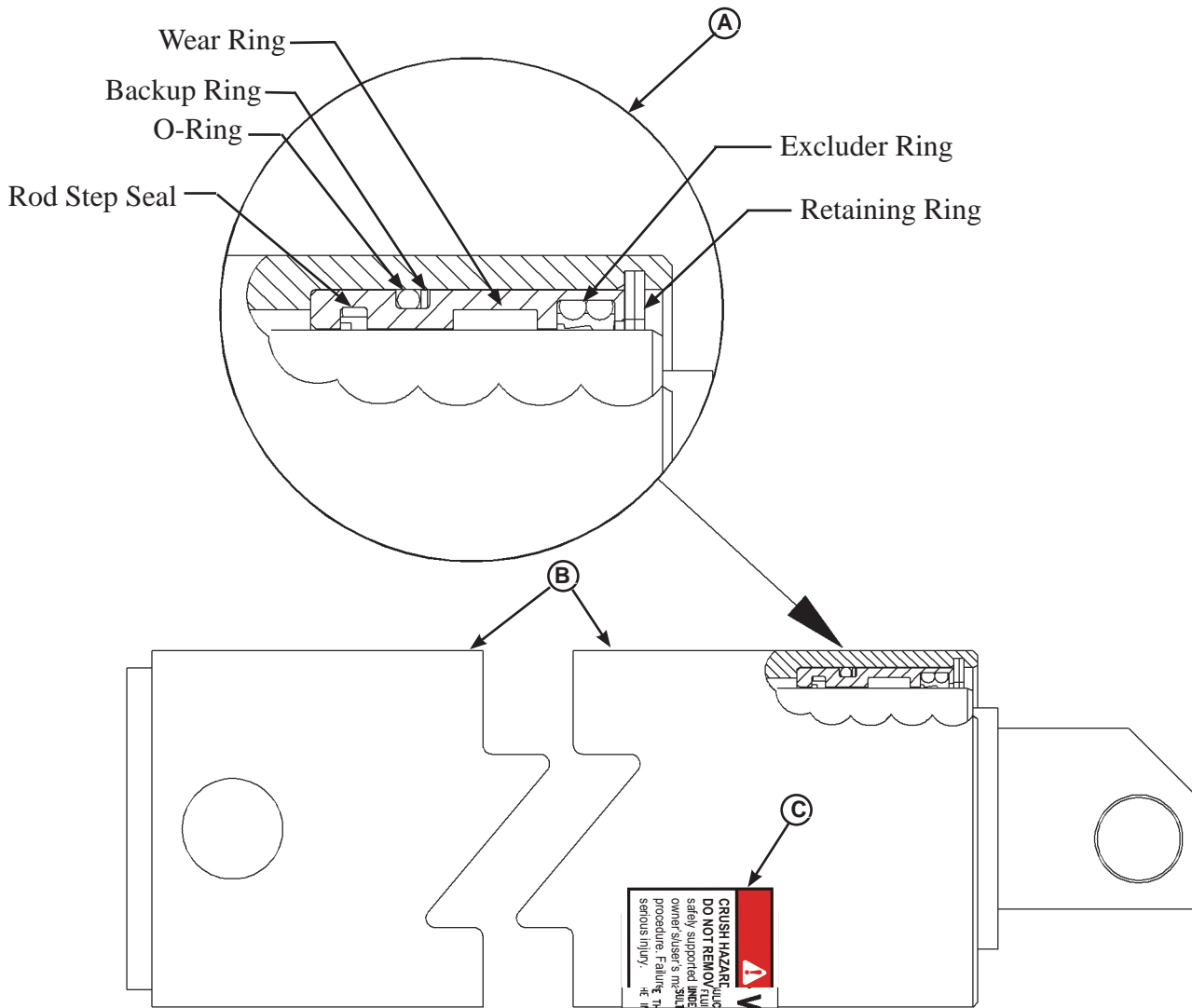

Item	Quantity	Part Number	Description
A	1	0525-0048	Seal Kit 1992 and Newer
		0525-0013	Seal Kit 1991 and Older
B	1	0525-0043	Cylinder, Platform, 15-1/2 in. (394 mm) Barrel Length
		0525-0044	Cylinder, Platform, 17-1/2 in. (445 mm) Barrel Length
		0525-0045	Cylinder, Platform, 19-1/2 in. (495 mm) Barrel Length
		0525-0046	Cylinder, Platform, 21-1/2 in. (546 mm) Barrel Length
C	1	1751-0138	Decal

*Provide dock leveler serial number when calling or faxing orders.

Lip Cylinder Repair Parts

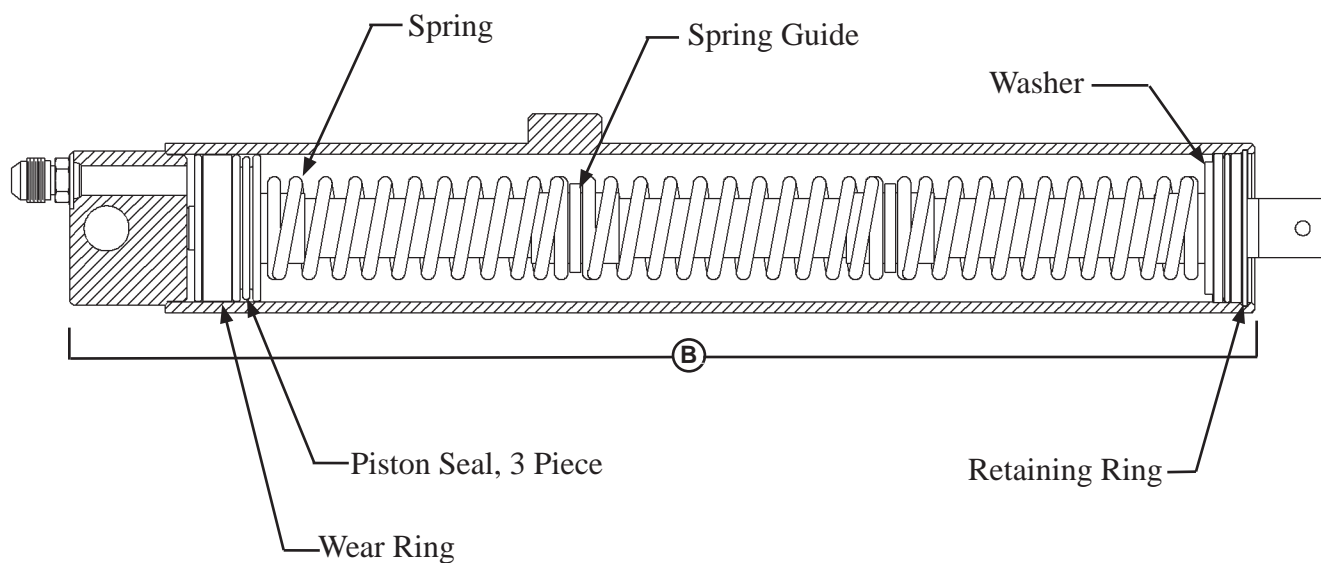

Item	Quantity	Part Number	Description
A	1	0525-0059	Seal Kit 1992 and Newer
		0025-0014	Seal Kit 1991 and Older
B	1	0525-0086	Lip Cylinder, Complete, 14 in. Barrel Length
		0525-0087	Lip Cylinder, Complete, 20 in. Barrel Length

*Provide dock leveler serial number when calling or faxing orders.

PARTS

Logic Block Assembly

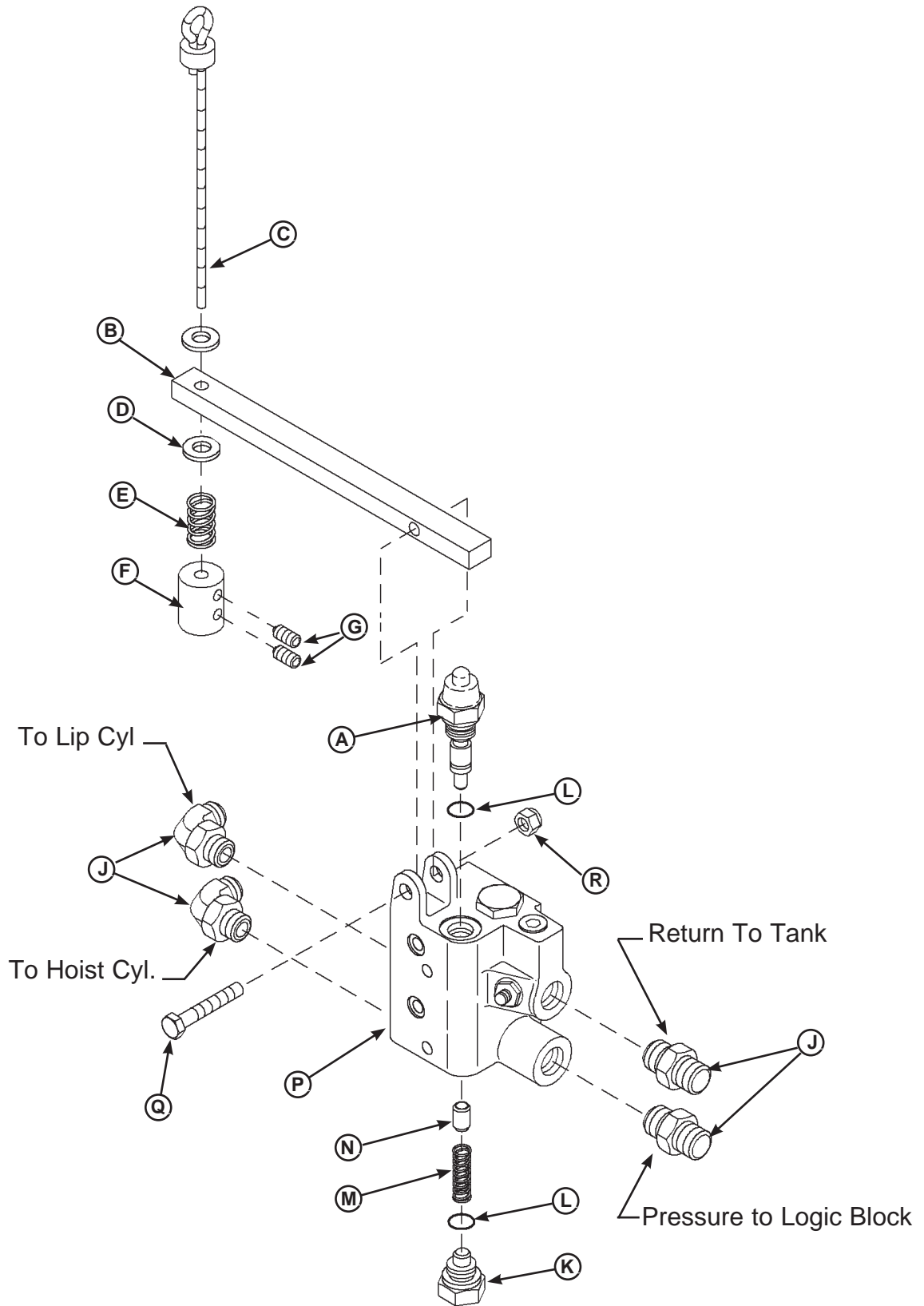

Logic Block Assembly

Logic Block and Lever Arm			
Item	Quantity	Part Number	Description
A	1	9574-0001	Spool Valve, Logic Block, Standard
		9574-0002	Spool Valve, Logic Block, Cold Weather
B	1	5402-0007	Lever Arm, Standard
		5402-0008	Lever Arm, Standard, Centra-Power
		5455-0006	Lever Arm, Cold Weather
		5455-0007	Lever Arm, Cold Weather, Centra-Power

Logic Block Cable Assembly			
Item	Quantity	Part Number	Description
C	1	7955-0001	Cable Subassembly, Logic Block
D	2	2101-0059	Washer, 1/4 in.
E	1	9572-0004	Spring
F	1	8102-0001	Weight, Logic Block Cable
G	2	2101-0032	Set Screw, Socket-Head, 1/4-20 UNC x 3/8 in.
H	1	5265-0002	Cable Weight Assembly, Logic Block (Includes Items C – H)

Logic Block Assembly			
Item	Quantity	Part Number	Description
J	2	9301-0112	Fitting, #8-ORB Male x #8-JIC Male
K	1	9572-0002	Plug, Spool Valve
L	2	9572-0003	Gasket, Spool Valve
M	1	9572-0004	Spring, Spool Valve
N	1	9572-0013	Dowel Pin, Cold Weather/Wash Down Feature Only
P	1	9575-0007	Logic Block, Complete (Includes Items A and K – N)
Q	1	2101-0098	Cap Screw, 5/16-18 UNC x 1-3/4 in.
R	1	2101-0039	Nylon Lock Nut, 5/16-18 UNC

PARTS

Power Pack Assembly, Metal Reservoir

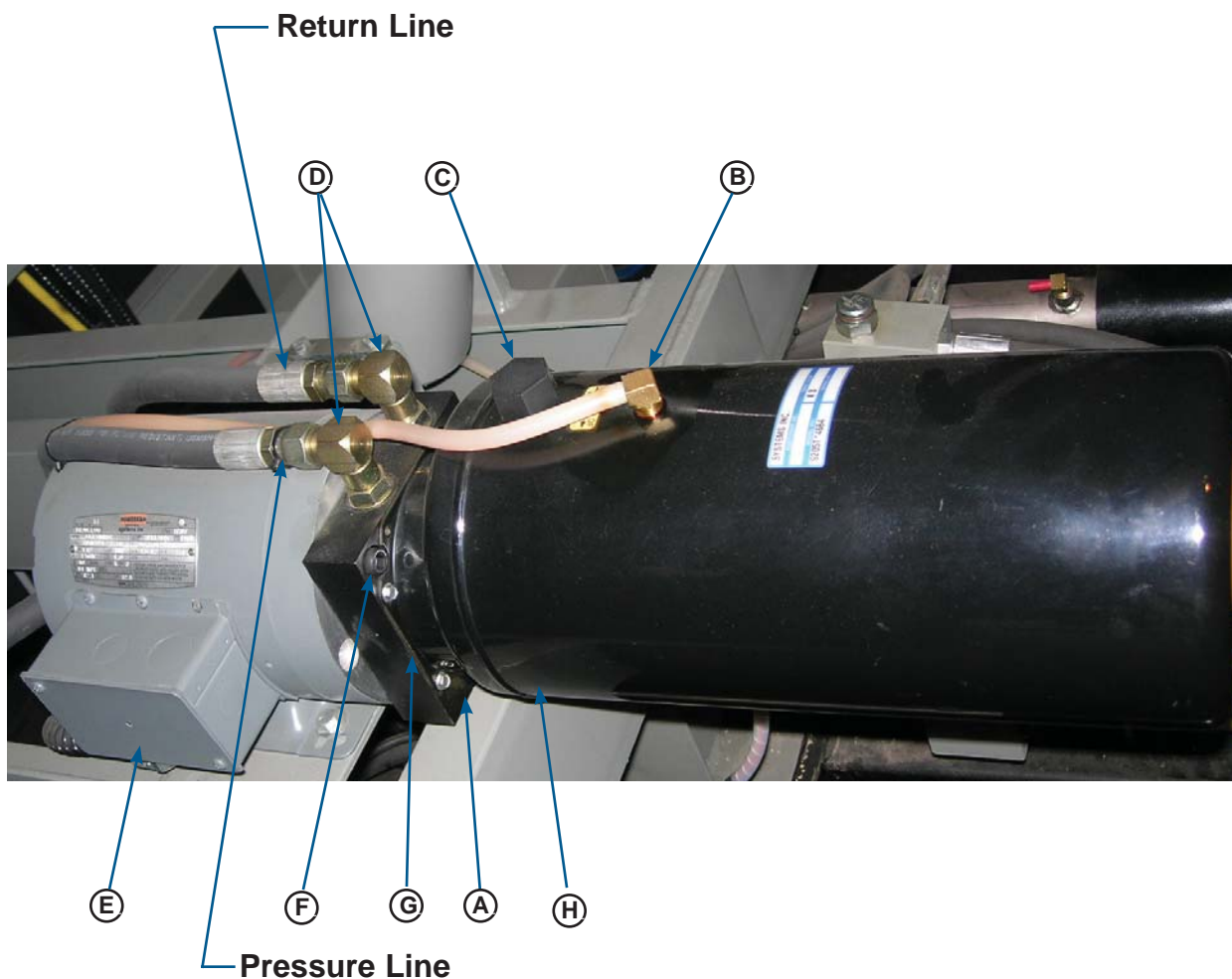

Item	Quantity	Part Number	Description
A	1	9301-____ ¹	Reservoir, Pump with Motor Drive Plate
B	1	0521-0007	90° Elbow, 1/4 NPT Male x 1/4 Tube
C	1	9301-0199	Breather Cap, 3/8 NPT Male
D	2	0521-0017	90° Elbow, 3/8 NPT Male x #8-JIC Male
E	1	3411-____ ²	Motor Only
F	4	2101-0016	Cap Screw, 5/16-18 UNC x 3-1/2 in., Grade 5
G	1	9301-0190	O-Ring
H	1	9301-0159	Metal Reservoir

¹ Provide dock leveler serial number and type of installation when calling or faxing orders.

² Provide dock leveler serial number, voltage, and phase when calling or faxing orders.

PARTS

Power Pack Assembly, Plastic Reservoir

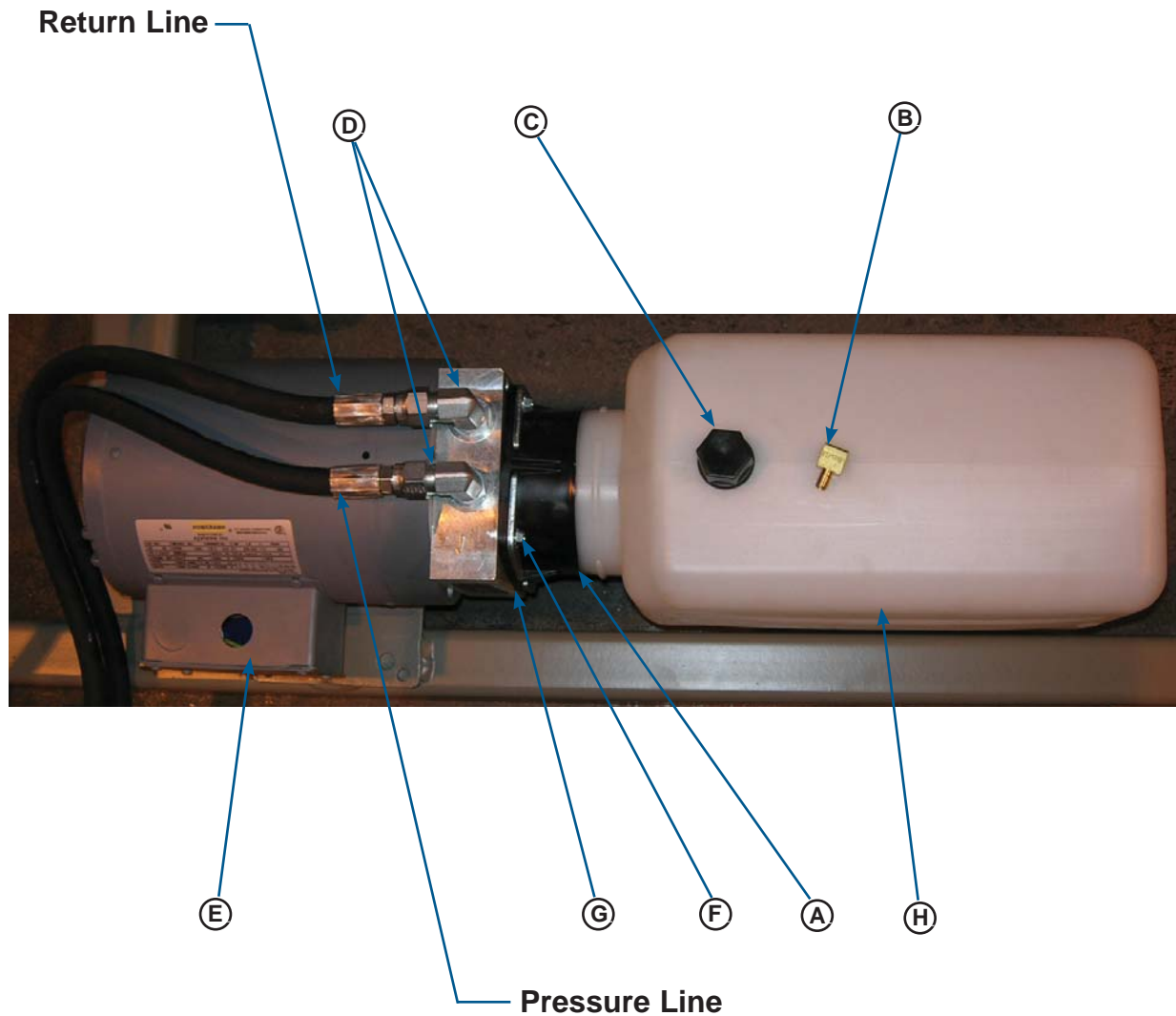

Item	Quantity	Part Number	Description
A	1	9301-0036	Reservoir, Pump with Motor Drive Plate
B	1	0521-0007	90° Elbow, 1/4 NPT Male x 1/4 Tube
C	1	9301-0218	Breather Cap, Push In
D	2	0521-0017	90° Elbow, 3/8 NPT Male x #8-JIC Male
E	1	3411-____ ²	Motor Only
F	4	2101-0225	Cap Screw, 5/16-18 UNC x 3-1/2 in., Grade 5
G	1	9301-0226	O-Ring
H	1	9301-0224	Plastic Reservoir

¹ Provide dock leveler serial number and type of installation when calling or faxing orders.

² Provide dock leveler serial number, voltage, and phase when calling or faxing orders.

PARTS

Power Pack Assembly, Low Amp Draw

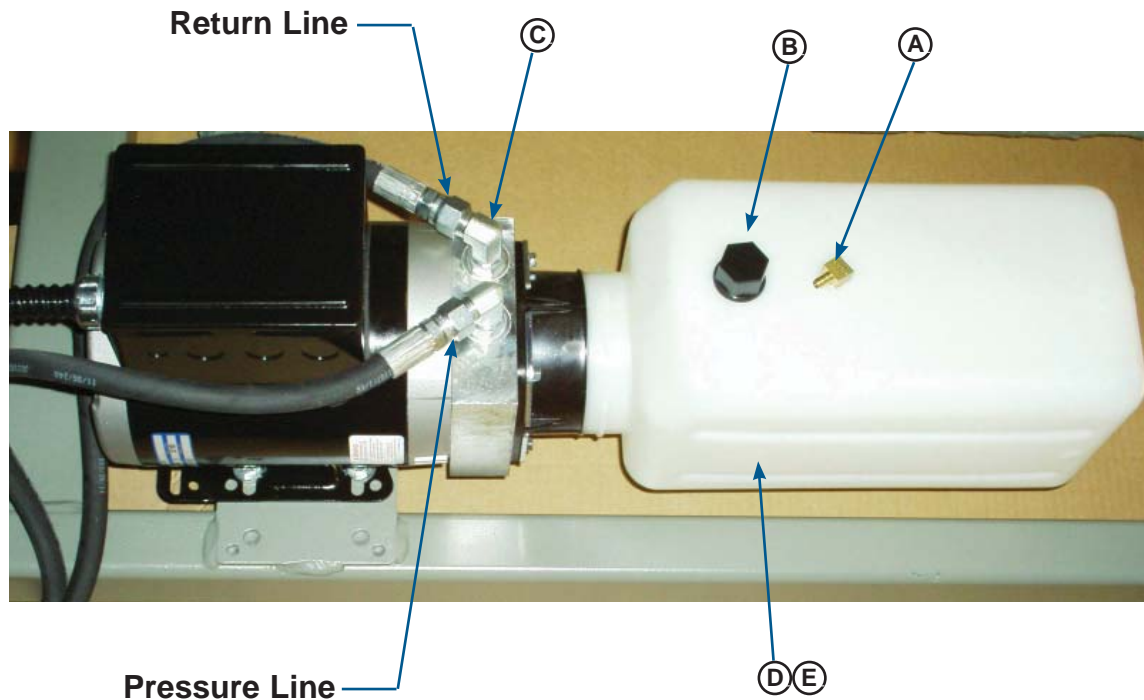

7.0 Amps @ 120 (volts consult factory)

Item	Quantity	Part Number	Description
A	1	0521-0007	90° Elbow, 1/4 NPT Male x 1/4 Tube
B	1	9301-0218	Breather Cap, Push In
C	2	0521-0201	90° Elbow, #8 ORB x #8-JIC Male
D	4	2101-0225	Cap Screw, 5/16-18 UNC x 3-1/2 in., Grade 5
E	1	9301-0226	O-Ring
F	1	9301-0224	Plastic Reservoir
G	1	9395-0404	Complete PPAC 115 Volt

← Provide dock leveler serial number, voltage, and phase when calling or faxing orders.

Weather Seal, Brush Style

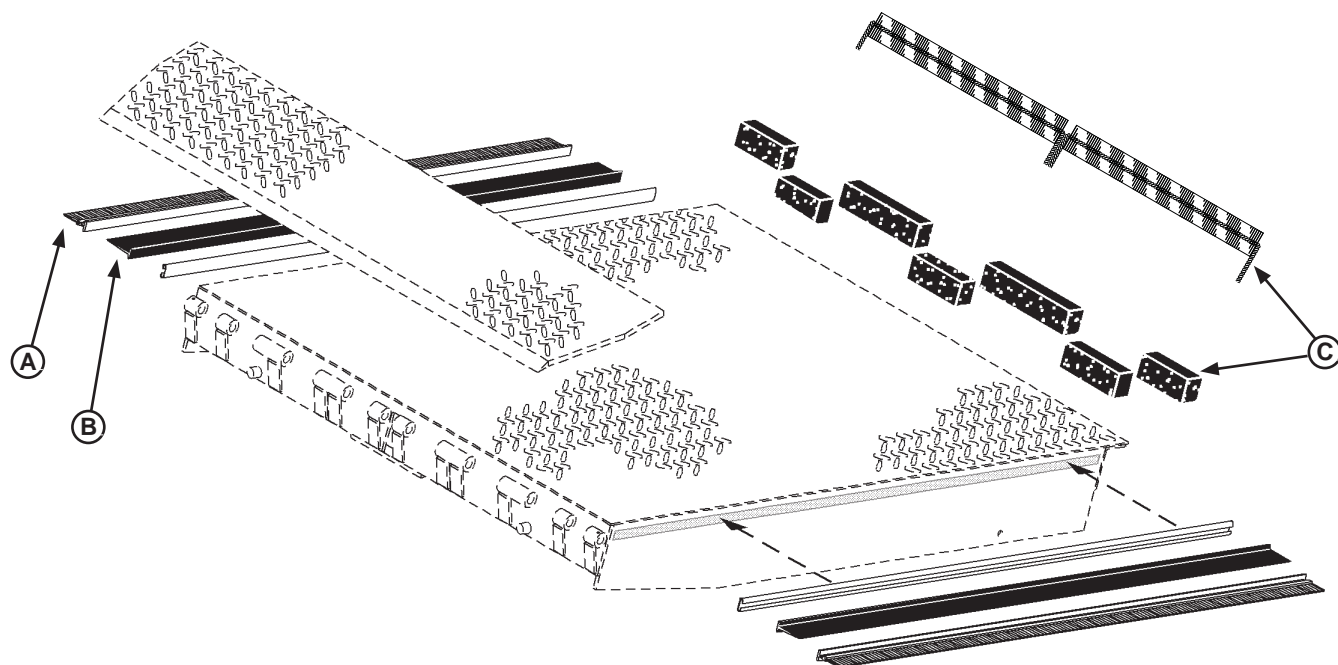

Item	Quantity	Part Number	Description
A	2	0195-0018	6' Brush Seal and track, 1 in. (25 mm)
	2	0195-0021	8' Brush Seal and track, 1 in. (25 mm)
	2	0195-0024	10' Brush Seal and track, 1 in. (25 mm)
	2	0195-0027	12' Brush Seal and track, 1 in. (25 mm)
B	2	0195-0030	6' Rubber Seal and track, 1 in (25 mm)
	2	0195-0033	8' Rubber Seal and track, 1 in (25 mm)
	2	0195-0036	10' Rubber Seal and track, 1 in (25 mm)
	2	0195-0039	12' Rubber Seal and track, 1 in (25 mm)
C	1	0192-____*	Foam Seal kit, Rear Hinge
	1	0195-0044	Rear Brush Weather Seal Fits all Sizes

AR = As Required

NOTE: Brush or track can be purchased separately as replacement parts. Contact factory for part numbers.

Kits are for existing dock leveler without weather seal.

* Provide dock leveler serial number and size of platform when calling or faxing orders.

*Provide width of weatherstrip when replacing existing seals

NOTES

This page intentionally left blank

Customer Information

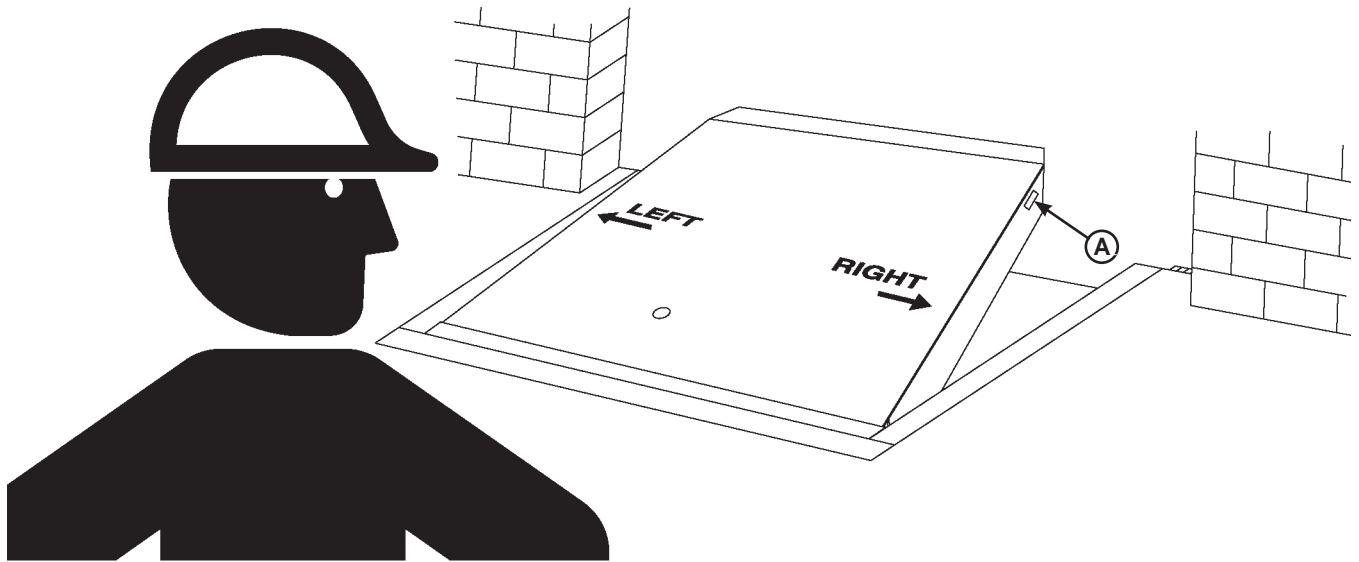

NOTE: Refer to illustration for left/right orientation of dock leveler.

The model/serial number decal (A) is located on the right platform joist near the front (lip) of dock leveler.

When you receive your VH dock leveler, write down the dock leveler model and serial number in the form provided. This will help ensure safe keeping of the numbers in the event the model/serial number decal (A) becomes lost or damaged.

Also, write down Systems, Inc.'s job number, the company that installed the dock leveler, and the original owner's name. This will all help to identify the specific dock leveler if more information is required.

When ordering, use part numbers and description to help identify the item ordered. Do not use "item" numbers. These are only for locating the position of the parts. Always give dock leveler MODEL NUMBER and/or SERIAL NUMBER.

For service, call or contact:

Systems, Inc.
P.O. Box 309
Germantown, WI 53022

Phone: (800) 643-5424
Fax: (262) 255-5917

<u>Dock Leveler Information</u>	
Model	_____
Serial No.	_____
Systems, Inc., Job No.	_____
<u>Original Owner Information</u>	
Name	_____
Address	_____ _____
<u>Installer Information</u>	
Name	_____
Address	_____ _____
Date of Installation	_____

STANDARD PRODUCT WARRANTY

SYSTEMS, INC. warrants that its products will be free from defects in design, materials and workmanship for a period of one (1) year from the date of shipment. All claims for breach of this warranty must be made within 30 days after the defect is or can with reasonable care, be detected. In no event shall any claim be made more than 30 days after this warranty has expired. In order to be entitled to the benefits of this warranty, the product must have been properly installed, maintained and operated in accordance with all manufacturer's recommendations and/or specified design parameters and not otherwise have been subject to abuse, misuse, misapplication, acts of nature, overloading, unauthorized repair or modification, application in a corrosive environment or lack of maintenance. Periodic lubrication, adjustment and inspection in accordance with all manufacturers' recommendations are the sole responsibility of the Owner/User.

In the event of a defect, as determined by SYSTEMS INC., covered by this warranty, SYSTEMS INC. shall remedy such defect by repairing or replacing any defective equipment or parts, bearing the cost for the parts, labor and transportation. This shall be exclusive remedy for all claims whether based on contract, negligence or strict liability.

WARRANTY LIMITATIONS

THE ABOVE WARRANTIES ARE IN LIEU OF ANY OTHER WARRANTIES, WHETHER EXPRESSED OR IMPLIED, INCLUDING BUT NOT LIMITED TO ANY IMPLIED WARRANTY OF MERCHANTABILITY OR FITNESS FOR A PARTICULAR PURPOSE. SYSTEMS INC. AND ITS SUBSIDIARIES SHALL NOT IN ANY EVENT BE LIABLE TO ANYONE, INCLUDING THIRD PARTIES, FOR INCIDENTAL, CONSEQUENTIAL OR SPECIAL DAMAGES OF ANY KIND INCLUDING BUT NOT LIMITED TO, BREACH OF WARRANTY, LOSS OF USE, LOSS OF PROFIT, INTERRUPTION OF BUSINESS OR LOSS OF GOODWILL.

PRODUCT SPECIFIC WARRANTY "VH" SERIES LEVELER

In addition to the "Standard Product Warranty" provided with all Poweramp® Products, Systems Inc., guarantees materials, components and workmanship to be free of defects for the following extended periods:

- Structural Warranty – For a period of five (5) years from the date of shipment, this warranty specifically applies to; the deck section, lip section, frame, rear hinge assembly and front hinge assembly only.
- Hydraulic Warranty – For a period of five (5) years from date of shipment, this warranty specifically applies to; the hydraulic pump and motor, all hydraulic cylinders, hydraulic pressure lines and fittings and fluid logic control assembly only.