

A Division of Systems, Inc.

POWERAMP[®]

Premium Loading Dock Systems

LHP SERIES

Dock Leveler

Owner's/User's Manual



POWERAMP • Division of Systems, Inc. • W194 N11481 McCormick Drive • Germantown, WI 53022
800.643.5424 • fax: 262.257.7399 • www.docksystemsinc.com • techservices@docksystemsinc.com

Printed in U.S.A.
Copyright © 2013

Manual No. 4111-0012
Aug 2012
April 2013

Table of Contents

	Page
Safety	
Recognize Safety Information	1
General Operational Safety Precautions	1
Operational Safety Precautions.....	2
Maintenance Safety Precautions.....	4
Safety Decals.....	5
Owner's User's Responsibilities	6
Introduction	
General Information.....	8
Dock Leveler Stock Specifications	8
Component Identification.....	9
Theory	9
Installation	
Prepare Pit	10
Prepare Dock Leveler	11
Install Dock Leveler	12
Install Control Panel and Wiring	18
Put New Leveler Into Service.....	19
Operation	
Operating Instructions	20
Ramp Loading/Unloading Instructions	21
End Loading/Unloading Instructions	22
Maintenance	
Service Dock Leveler Safely	23
Periodic Maintenance	24
Adjustments	
Adjust Main Pressure Relief	27
Lip Function	28
Parts	
Components	32
Controls	38
Hydraulic Components.....	34
Weather Seal, Rubber Style & Toe Guards	36
Weather Seal, Brush Style	36
Miscellaneous	
Electrical Wiring Single Phase	30
Electrical Wiring Three Phase	31
Customer Information	41
Warranty.....	Back Cover

Recognize Safety Information

Safety-Alert Symbol

The <u>Safety-Alert Symbol</u> identifies important safety messages on equipment, safety signs, in manuals, or elsewhere. When you see this symbol, be alert to the possibility of personal injury or death. Follow the instructions in the safety message.

 DANGER
The use of the word <u>DANGER</u> signifies the presence of an extreme hazard or unsafe practice which will most likely result in severe injury or death.

 WARNING
The use of the word <u>WARNING</u> signifies the presence of a serious hazard or unsafe practice which may result in serious injury or death.

 CAUTION
The use of the word <u>CAUTION</u> signifies possible hazard or unsafe practice which could result in personal injury.

IMPORTANT
The use of the word <u>IMPORTANT</u> is to draw attention to a procedure that needs to be followed to prevent machine damage.

General Operational Safety Precautions

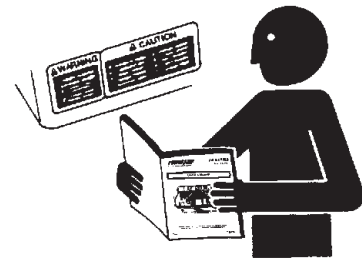

Read and understand the operating instructions and become thoroughly familiar with the equipment and its controls before operating the dock leveler.

Never operate a dock leveler while a safety device or guard is removed or disconnected.

Never remove DANGER, WARNING, or CAUTION signs or decals on the equipment unless replacing them.

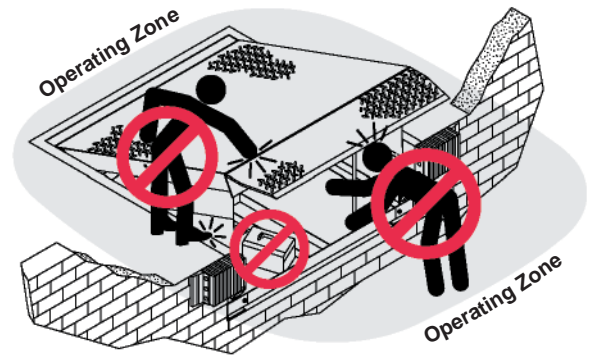

Do not start the equipment until all unauthorized personnel in the area have been warned and have moved outside the operating zone.

Remove any tools or foreign objects from the operating zone before starting.

Keep the operating zone free of obstacles that could cause a person to trip or fall.

SAFETY

Operational Safety Precautions

Learn the safe way to operate this equipment. Read and understand the manufacturer's instructions. If you have any questions, ask your supervisor.



DANGER



Stay clear of dock leveling device when transport vehicle is entering or leaving area.



Do not move or use the dock leveling device if anyone is under or in front of it.



Keep hands and feet clear of pinch points. Avoid putting any part of your body near moving parts.

WARNING



Chock/restrain all transport vehicles. Never remove the wheel chocks until loading or unloading is finished and truck driver has been given permission to drive away.



Do not use a broken or damage dock leveling device. Make sure proper service and maintenance procedures have been performed before using.

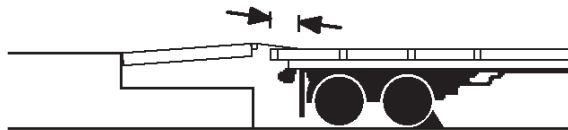

Make sure lip overlaps onto transport vehicle at least 4 in. (102 mm).

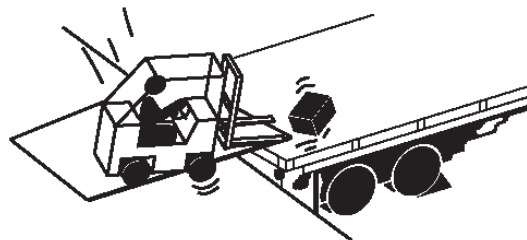

Keep a safe distance from both side edges.

⚠ WARNING

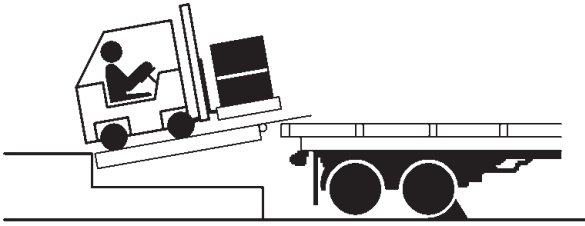

Do not use dock leveling device if transport vehicle is too high or too low.

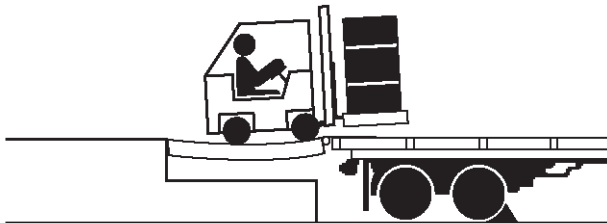

Do not overload the dock leveling device.

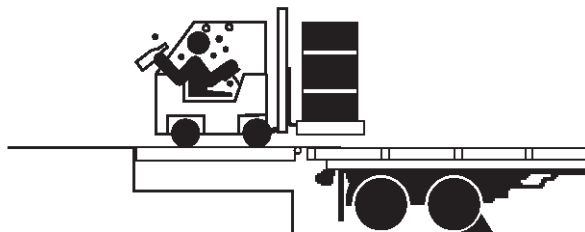

Do not operate any equipment while under the influence of alcohol or drugs.

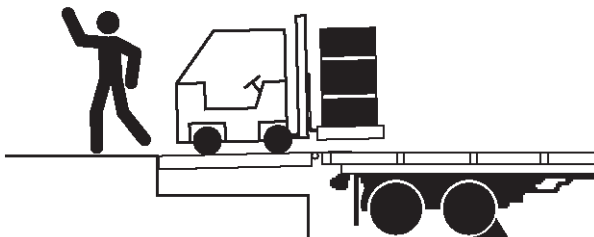

Do not leave equipment or material unattended on dock leveling device.

SAFETY

Maintenance Safety Precautions

DANGER

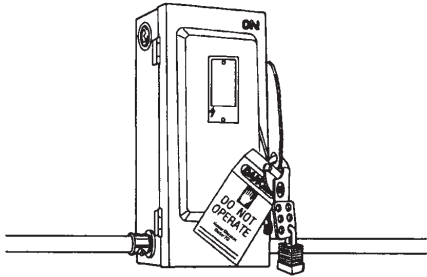

Hydraulic and electrical power must be OFF when servicing the equipment. For maximum protection, use an OSHA approved locking device to lock out all power sources. Only the person servicing the equipment should have the key to unlock the device.

CAUTION



Always post safety warnings and barricade the work area at dock level and ground level to prevent unauthorized use of the unit before maintenance is complete.

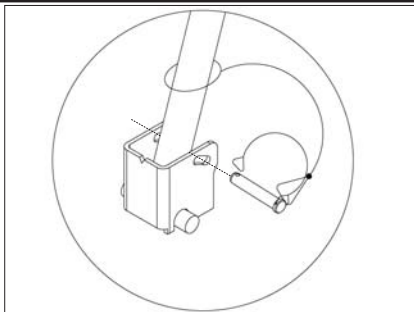

The maintenance prop must be in the upright "service" position when working under the dock leveler. For maximum protection, use an OSHA approved locking device to lock the maintenance prop in the service position. Only the person servicing the equipment should have the key to unlock the device.

WARNING

ALWAYS disconnect electrical power source and ground wire before welding on dock leveler.

DO NOT ground welding equipment to any hydraulic or electrical components of the dock leveler. Always ground to the dock leveler frame.

Failure to follow these instructions may result in damage to dock leveler and/or serious personal injury or death.

WARNING

DO NOT grind or weld if hydraulic fluid or other flammable liquid is present on the surface to be ground or welded

DO NOT grind or weld if uncontained hydraulic fluid or other flammable liquid is present. Stray sparks can ignite spills or leaks near the work area. Always clean up the oil leaks and spills before proceeding with grinding or welding.

Always keep a fire extinguisher of the proper type nearby when grinding or welding.

Failure to follow these instructions may result in serious personal injury or death.

WARNING

ALWAYS stand clear of dock leveler lip when working in front of the dock leveler. Failure to do this may result in serious personal injury or death.

DANGER



**Arc Flash and Shock Hazard
PPE (Personal Protection Equipment) Required**

De-energize equipment before working on or inside. Do not open cover without appropriate PPE. Refer to NFPA 70E for PPE requirements. This panel may contain more than one power source.

**Hazardous Voltage
Will Cause Severe
Injury or Death**

Refer to OSHA regulation 1910.146
Refer to OSHA regulation 1910.147

Safety Decals

Every 90 days (quarterly) inspect all safety labels and tags to ensure they are on the dock leveler and are easily legible. If any are missing or require replacement, please call 1-800-643-5424 for replacements.

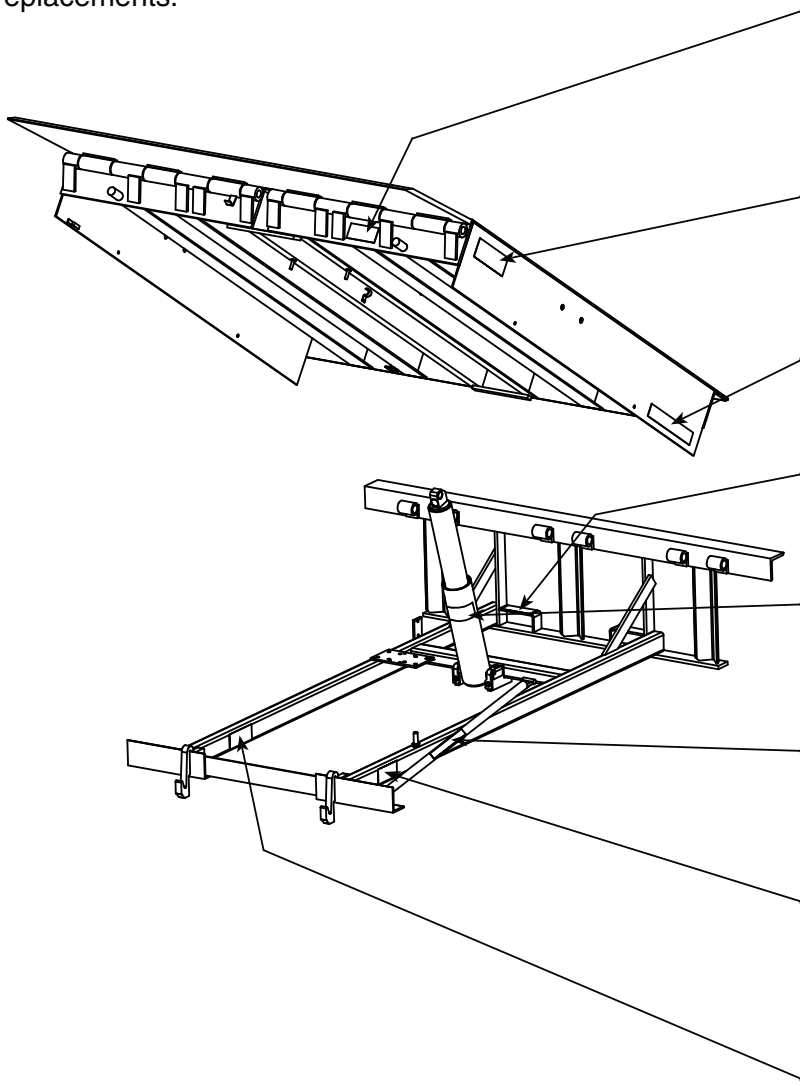

<p>1751-0727</p>	
<p>1751-0730 (x2)</p>	
<p>1751-0329 (x2)</p>	
<p>1751-0330 (x2)</p>	
<p>1751-0138</p>	
<p>1751-0729</p>	
<p>1751-0731</p>	
<p>1751-0726</p>	

OWNER'S/USER'S RESPONSIBILITIES

1. The owner/ user should recognize the inherent dangers of the interface between the loading dock and the transport vehicle. The owner/ user should, therefore, train and instruct all operators in the safe operation and use of the loading dock equipment in accordance with manufacturer's recommendations and industry standards. Effective operator training should also focus on the owner's/user's company policies and operating conditions. Maintaining, updating and re training all operators on safe working habits and operation of the equipment, regardless of previous experience, should be done on a regular basis and should include an understanding and familiarity with all functions of the equipment. Owner's/ user's shall actively maintain, update and retrain all operators on safe working habits and operations of the equipment.
2. The manufacturer shall provide to the initial purchaser all necessary information regarding Safety Information, Operation, Installation and Safety Precautions, Recommended Initial and Periodic Inspections Procedures, Planned Maintenance Schedule, Product Specifications, Troubleshooting Guide, Parts Break Down, Warranty Information, and Manufacturers Contact Information, as well as tables to identify the grade(slope) for all variations of length or configuration of the dock leveling device and information identifying the maximum uncontrolled drop encountered when sudden removal of support while in the working range of the equipment.
3. It is recommended that when the transport vehicle is positioned correctly in the dock opening and in contact with both bumpers, there shall be a minimum of 4.00 inches (100mm) overlap of the leveling device and the transport vehicle at all times during the loading and unloading process.
4. The Owner/User must review all name plates, placards, decals, instructions and posted warnings and place the same in view of the operator or maintenance personnel for whom such warnings are intended for. Contact manufacturer for any replacements.
5. Manufacturer's recommended periodic maintenance and inspection procedures in effect at the date of shipment shall be followed at all times. Written documentation of maintenance, replacement parts or damage should be retained. In the event of damage notification to the manufacturer is required.
6. Loading dock equipment that has been structurally damaged or has experienced a sudden loss of main support while under load (such as what might occur when a transport vehicle pulls out from under the leveling device) shall be removed from service, inspected by a manufacturer's authorized representative, and repaired or replaced as needed before being placed back in service.
7. Any modifications or alterations of loading dock equipment shall only be done with prior written approval from the manufacturer and the same shall be at least as safe as the original equipment was prior to the modification and shall also satisfy all safety requirements of the manufacturer for the particular application of the leveling device.
8. When industrial moving devices are being used in the loading or unloading of product from the transport vehicle, this vehicle shall have the brakes and wheel chocks applied appropriately or all other positive restraining device shall be fully utilized. It is recommended that trailers with air-ride suspension systems shall have its air exhausted prior to performing loading and unloading operation to minimize trailer bed drop.
9. Loading dock safety equipment should never be used outside of its intended use, vertical working range, or capacity. Please consult the manufacturer if you have any questions as to the use, vertical working range or capacity of the equipment. Only properly trained and authorized personnel should operate the equipment.
10. When selecting loading dock safety equipment, it is important to consider not only present requirements but also future plans and any possible adverse conditions, environmental factors or usage.

INTRODUCTION

General Information

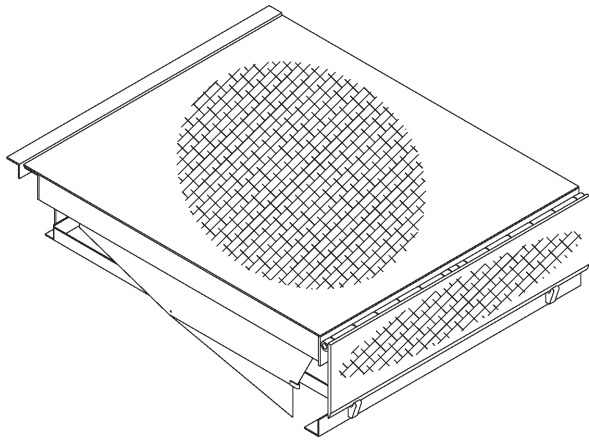

Congratulations on your choice of a Systems, Inc. dock leveler. This manual covers the LHP series hydraulic dock leveler.

Designed by Systems, Inc. to be a marvel of simplicity and efficiency. Your dock leveler, when properly installed, will provide many years of trouble-free performance with an absolute minimum of maintenance. Its revolutionary hydraulic system efficiently controls and operates every function. To obtain maximum performance and longest possible use, a simple program of preventive maintenance is recommended.

The LHP series dock leveler comes equipped with an electrical control panel, which allows pushbutton operation of the dock leveler functions. Each LHP dock leveler unit and control panel has been factory prewired and tested to ensure satisfactory operation.

To illustrate which connections are to be made in the field at installation, electrical drawings are included with each order or by contacting Systems, Inc. Technical Services.

Once again, thank you and congratulations on your purchase of a Systems, Inc. hydraulic dock leveler.

Dock Leveler Stock Specifications

LHP dock levelers are available in the following sizes, weight capacities, and options:

Width

- 6 ft (1828.8 mm)
- 6-1/2 ft (1981.2 mm)
- 7 ft (2133.6 mm)

Length

- 6 ft (1828.8 mm)
- 8 ft (2438 mm)
- 10 ft (3048 mm)

Capacity (CIR*)

- 25,000 lb (11 340 kg)
- 35,000 lb (15 876 kg)
- 40,000 lb (18 144 kg)

* CIR (Comparative Industry Rating)

Call Systems Inc to discuss available voltages, phases and options to meet your specific needs.

Component Identification

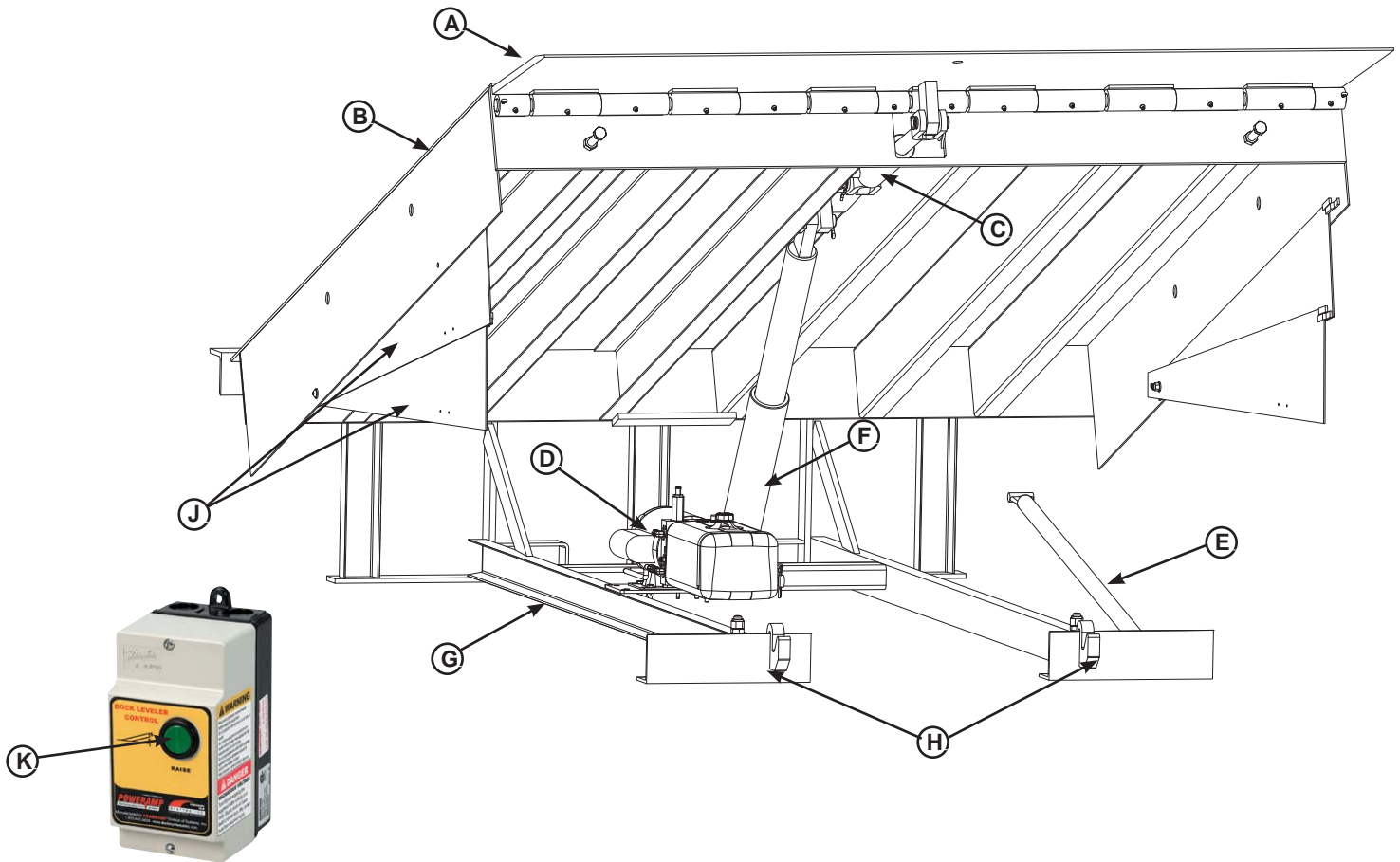

- | | | | |
|------------------|--------------------------------------|--------------------------|-----------------------------------|
| A — Lip | D — Powerpack (Motor/Pump/Reservoir) | G — Main Frame | J — Full Range Toe Guard (4 used) |
| B — Platform | E — Maintenance Prop | H — Lip Keepers (2 used) | K — Raise Button |
| C — Lip Cylinder | F — Platform Cylinder | | |

THEORY

The LHP dock leveler uses a pressure operated valve block and single push-button operation for ease of use.

The dock leveler can be operated remotely using the RAISE button (K) on the control panel .

Platform (B) is raised by pushing and holding the RAISE button (K). This activates an electric motor (D) which, in turn, drives a hydraulic pump. The hydraulic pump forces oil into the platform cylinder (F), causing the platform to rise. Releasing the RAISE button allows the platform to lower.

When the platform rises and the hoist cylinder is fully extended, the internal valving redirects the flow of oil to the lip cylinder (C). This causes the platform to stop rising and lip (A) to extend. When the lip has fully extended, the hydraulic oil will flow past the pressure relief valve and back to the oil reservoir.

Releasing the raise button will allow the platform to float down to the below dock position. The lip will stay extended until the platform reaches the full below dock position.

Pressing the raise button will return the platform and lip to the stored position.

INSTALLATION

Prepare Pit

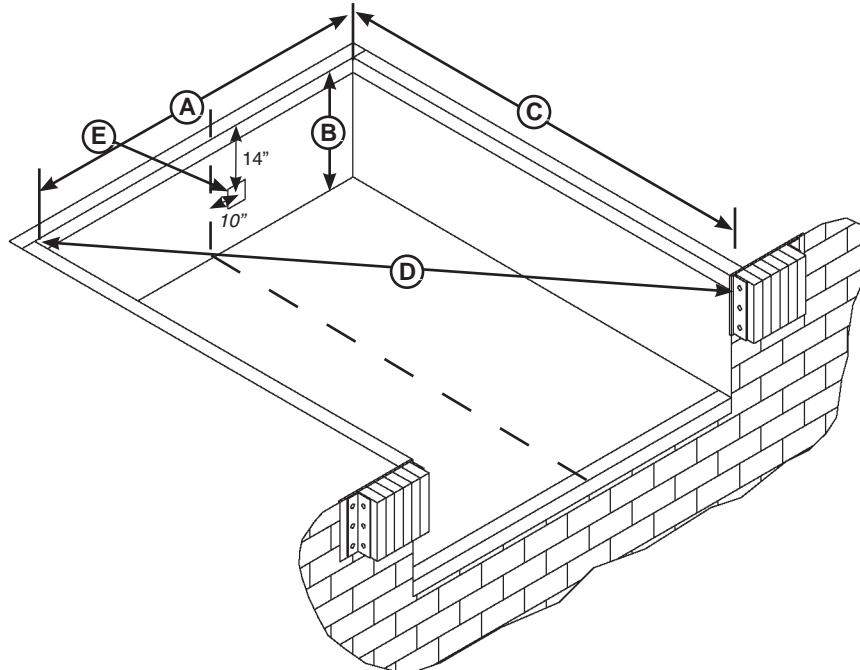

A—Distance (Pit Width)
(Front and Rear)

B—Distance (Dock Floor-to-Pit
Floor) (All Four Corners)

C—Distance (Pit Length)
(Both Sides of Pit)

D—Distance (Pit Corner-to-Corner)
(Top, Bottom, and Both Sides)



WARNING

Post safety warnings and barricade the work area at dock level and ground level to prevent unauthorized use of the dock leveler before installation has been completed.

Failure to follow the installation instructions can result in damage to dock leveler, the facilities, and/or serious personal injury or death.



CAUTION

Only trained installation professionals with the proper equipment should install this product.

IMPORTANT

DO NOT remove the shipping bands around the dock leveler lip until instructed to do so.

1. Before lowering the dock leveler into the pit, the following must be performed:
 2. Remove all debris from the pit and sweep the pit clean.
 3. Check the entire dock leveler pit for proper construction according to approved/certified pit drawings. Make sure pit is square by making the following measurements:
 - Measure pit width distance (A) at both front and rear of pit.
 - Measure dock floor-to-pit floor distance (B) at all four corners.
 - Measure pit length distance (C) at sides.
 - Measure corner-to-corner (criss-cross) distance (D) at both sides. Take measurements at dock floor level and at pit floor level.
- If any measurement is off by more than 1/8 in. (3.18 mm), contact Poweramp Technical Services before proceeding.
4. Make sure the field junction box for the dock leveler (E) is at the correct location per pit diagrams.

Prepare Dock Leveler

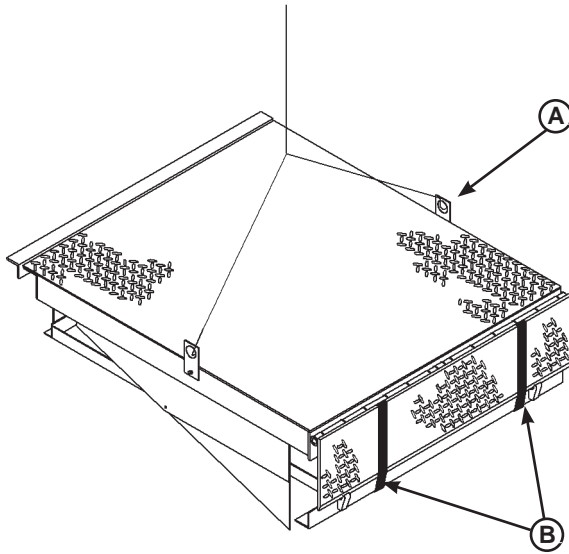

A— Lifting Bracket (2 used)

B — Shipping Bands

Systems, Inc. dock levelers are designed with installation in mind. Each unit is shipped with lifting brackets (A) fastened to the platform side joists.

WARNING

The dock leveler is heavy. Use a lifting device and chains with the appropriate lifting capacity and reach.

Always use the lifting brackets provided with the unit whenever lowering or lifting a dock leveler into or out of a pit.

Failure to follow these instructions may result in damage to dock leveler and/or serious personal injury or death.

IMPORTANT

DO NOT remove the shipping bands (B) around the platform lip and leveler frame at this time. The shipping bands are needed to hold the leveler together during the installation process.

1. Remove any control panel and bumpers that may be banded to the frame of the dock leveler. DO NOT remove the shipping bands (B) around the platform lip and leveler frame at this time.

IMPORTANT

DO NOT overtighten the lifting bracket hardware. Overtightening can damage the weather seal, if equipped.

NOTE: Overall width of platform and lifting brackets (A) must be kept to a minimum to prevent interference between the lifting brackets and the pit walls as the dock leveler is lowered into the pit.

2. Make sure the mounting hardware of lifting brackets (A) is snug. The brackets should pivot relatively freely on the mounting cap screw. DO NOT overtighten.
3. Attach lifting chains to lifting brackets (A) and to a lifting device (i.e., hoist or fork truck) having the appropriate lifting capacity and reach.
4. Remove wood blocks that are attached to the leveler frame before putting the dock leveler into the pit.

INSTALLATION

Install Dock Leveler

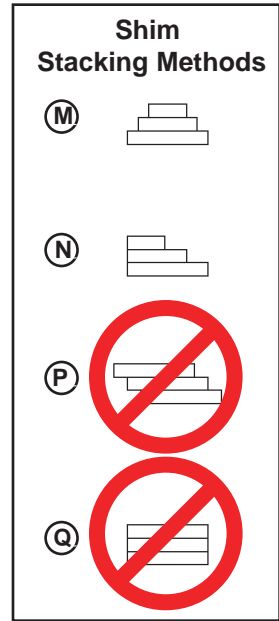
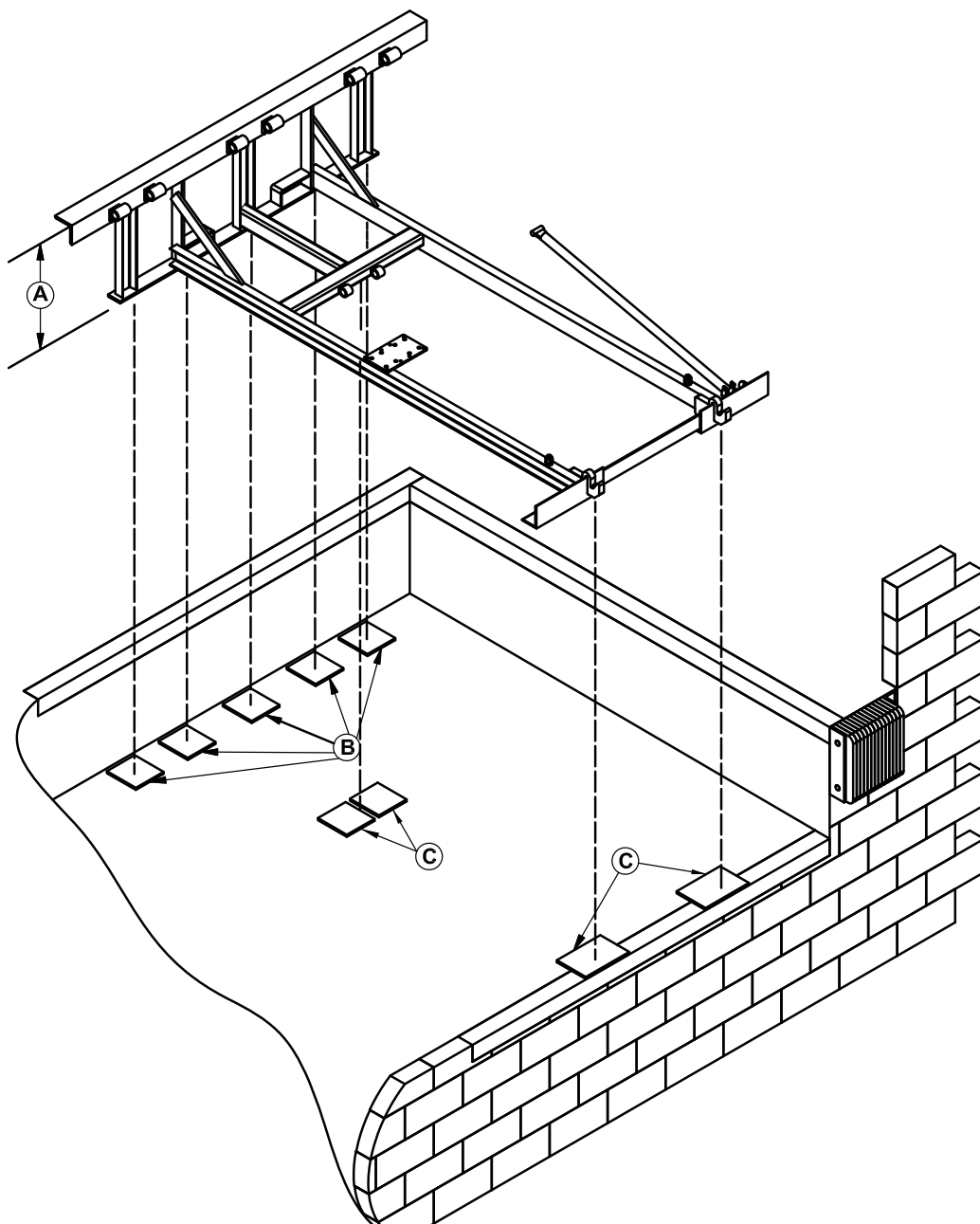

- A— Distance (Leveler Frame Height)
- B— Shim Locations (Under Rear Vertical Supports)
- C— Shim Location (Under Maintenance Prop, Lip Keepers, Main Cylinder)
- D— Dock Floor
- E— Rear Pit Curb Steel
- F— String
- G— Rear Hinge frame Angle
- H— Distance (Dock floor-To-Pit Floor)
- J— Distance (TOP of Shim to Dock Floor)
- K— Shim Stack
- L— Dock Leveler Base Frame
- M— Pyramid (Preferred)
- N— Stepped (Acceptable)
- P— Offset (Not Acceptable)
- Q— Straight (Not Acceptable)

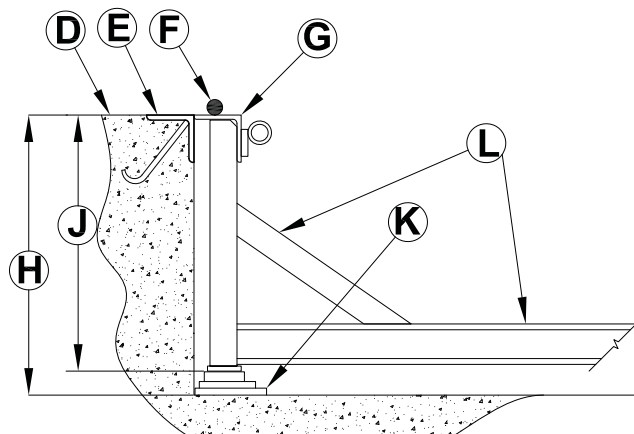

NOTE: Systems, Inc. dock levelers are designed with a nominal 1/2 in. (12.7 mm) shimming distance to allow for pit inconsistencies.

1. Determine height of shim stack (L) for each shim location (B) by performing the following:
 - a. Measure leveler frame height distance (A).
 - b. Measure dock floor-to-pit floor distance (J) at each shim location (B). Write down the dimensions obtained at each location.
 - c. Subtract distance (A) from distance (J) to obtain the shim height. Repeat for each shim location.

IMPORTANT

The minimum size of the shim that contacts the leveler frame (i.e., the top shim of each shim stack) must be at least 4-1/2 x 4-1/2 in. (114.3 x 114.3 mm) to support the full width of the frame rail and to provide a shelf for a fillet weld.

Use the thickest shim stock possible for stability and weld penetration purposes. DO NOT use multiple layers of 1/8 in. (3.18 mm) or thinner shim stock.

2. Using the results obtained in step 1, create the individual shim stacks on the pit floor at locations (B). Build each shim stack (L) using the pyramid method (N) (preferred) or stepped method (P) with the top shim having a minimum size of 4-1/2 x 4-1/2 in. (114.3 x 114.3 mm) and each successive lower shim being larger so the shims can be welded together using a fillet weld. DO NOT use offset method (Q) or straight method (R).

NOTE: To assist in obtaining an accurate measurement of distance (K), use a string (G) pulled tight across the pit opening, directly over the shim locations.

3. Verify that each shim stack is at the correct height by measuring distance (K) [top of shim stack (L) to dock floor]. Distance (K) must equal the dock leveler height (A).

4. For all LHP models, put a 1/4 in. (6.6 mm) thick shim at locations (C and D) .

NOTE: A 1/4 in. (6.6 mm) thick shim at locations (C and D) is used only as a starting point. The final shim stack height will be determined after dock leveler is lowered into the pit.

WARNING

The dock leveler is heavy. Use chains and a lifting device with the appropriate lifting capacity and reach. Failure to do so may result in damage to dock leveler and/or serious personal injury or death.

5. Using an appropriate lifting device connected to the lifting brackets, lower dock leveler into the pit so rear hinge frame angle (H) is tight against rear pit curb angle (F) across full width of the leveler frame.
6. Allow rear of dock leveler to rest on the rear shims while keeping the front of the dock leveler level with the dock floor.
7. For all LHP models, add shims at front shim locations (C and D) so front of dock leveler will stay level with dock floor when leveler is resting fully on shims.

INSTALLATION

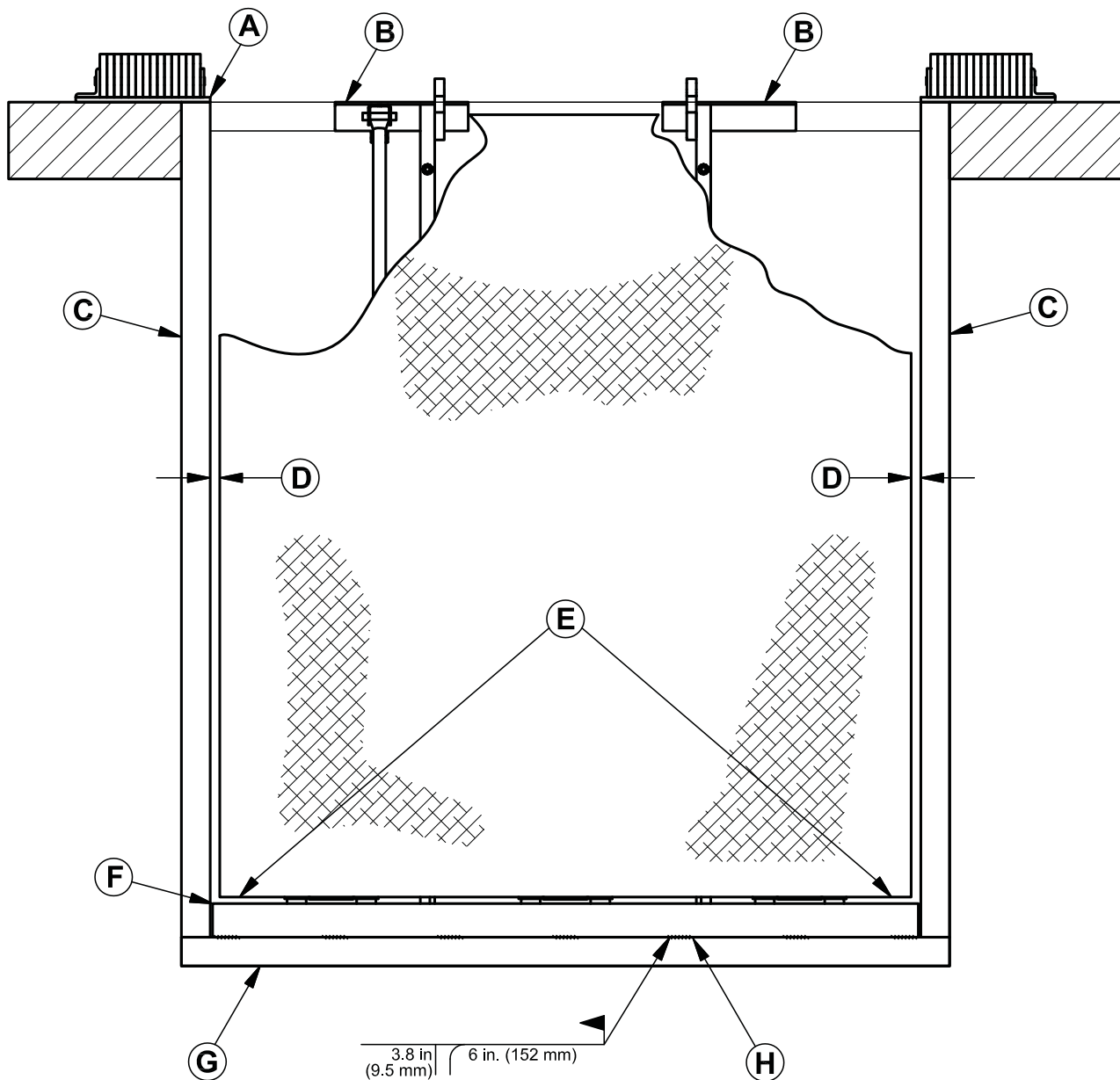

- | | | | |
|-----------------------|----------------------------------|---------------------------|---|
| A— Front of Dock Pit | C— Side Pit Curb Angle | E— Pry Locations | G— Rear Pit Curb Angle |
| B— Dock Leveler Frame | D— Gap [3/4 in. (19 mm) Minimum] | F— Rear Hinge Frame Angle | H— Flare Bevel Weld, Typical (To Fit Spacing) |

8. With rear hinge frame angle (F) tight against rear pit curb angle (G), perform/check the following:
 - Pry between the platform and rear hinge frame angle at locations (E) to make sure rear edge of platform is parallel to the rear hinge frame angle (F).
 - Gap (D) must exist equally along both sides of leveler so weather seal (if equipped) will not bind during dock leveler operation.
9. If gap (D) cannot be obtained equally at both sides of leveler, grind or add material at the rear edge of rear hinge frame angle (F) as needed.
10. Allow the dock leveler to rest fully on the shim stacks. Check that a smooth and level transition exists between the dock floor and the dock leveler platform. Add or remove shims as necessary until a smooth transition is obtained.
11. If leveler cannot be squared and/or made level as instructed in steps 8 — 10, contact Systems, Inc. Technical Services.



WARNING

DO NOT grind or weld if hydraulic fluid or other flammable liquid is present on the surface to be ground or welded.

DO NOT grind or weld if uncontained hydraulic fluid or other flammable liquid is present. Stray sparks can ignite spills or leaks near the work area. Always clean up the oil leaks and spills before proceeding with grinding or welding.

Always keep a fire extinguisher of the proper type nearby when grinding or welding.

Failure to follow these instructions may result in serious personal injury or death.

IMPORTANT

DO NOT connect the dock leveler electrical wiring and ground connections until all welding has been completed.

DO NOT ground welding equipment to any hydraulic or electrical components of the dock leveler. Always ground welding equipment to the dock leveler frame, NEVER to the platform.

Failure to follow these instructions may damage the motor, hoist cylinder, wiring, and/or control panel.

NOTE: The illustration on the previous page shows a typical weld pattern. The weld pattern will vary slightly depending on size of dock leveler.

IMPORTANT

DO NOT weld continuously along the full length of the rear hinge frame angle. This can put unnecessary stress on the leveler components, causing the leveler to malfunction and shorten the lifespan of the affected components.

11. With the rear hinge frame angle (F) tight against the rear pit curb angle (G), weld the rear hinge frame angle (F) to the rear pit curb angle (G) using a 3/8 in. (9.5 mm) flare bevel skip weld — each weld being 6 in. (152 mm) long.

Start at each end with a 6 in. (152 mm) long weld. Space all the other welds out evenly leaving approximately 6 in. (152 mm) space between each weld.

12. Weld front of dock leveler frame (B) to shims located under the keepers, then weld the shims to the front pit curb steel.
13. With leveler welded into place, remove the shipping bands from around lip and leveler frame.



WARNING

If the platform is raised using an external lifting device or the hydraulic system is opened to atmosphere, air will enter into the hydraulic system.

Whenever this happens, always cycle the leveler at least 4 times using the leveler's own hydraulic power system before allowing the leveler to be put into service. This is to make sure all air is purged from the hydraulic cylinders. Failure to do this may result in serious personal injury or death.

INSTALLATION

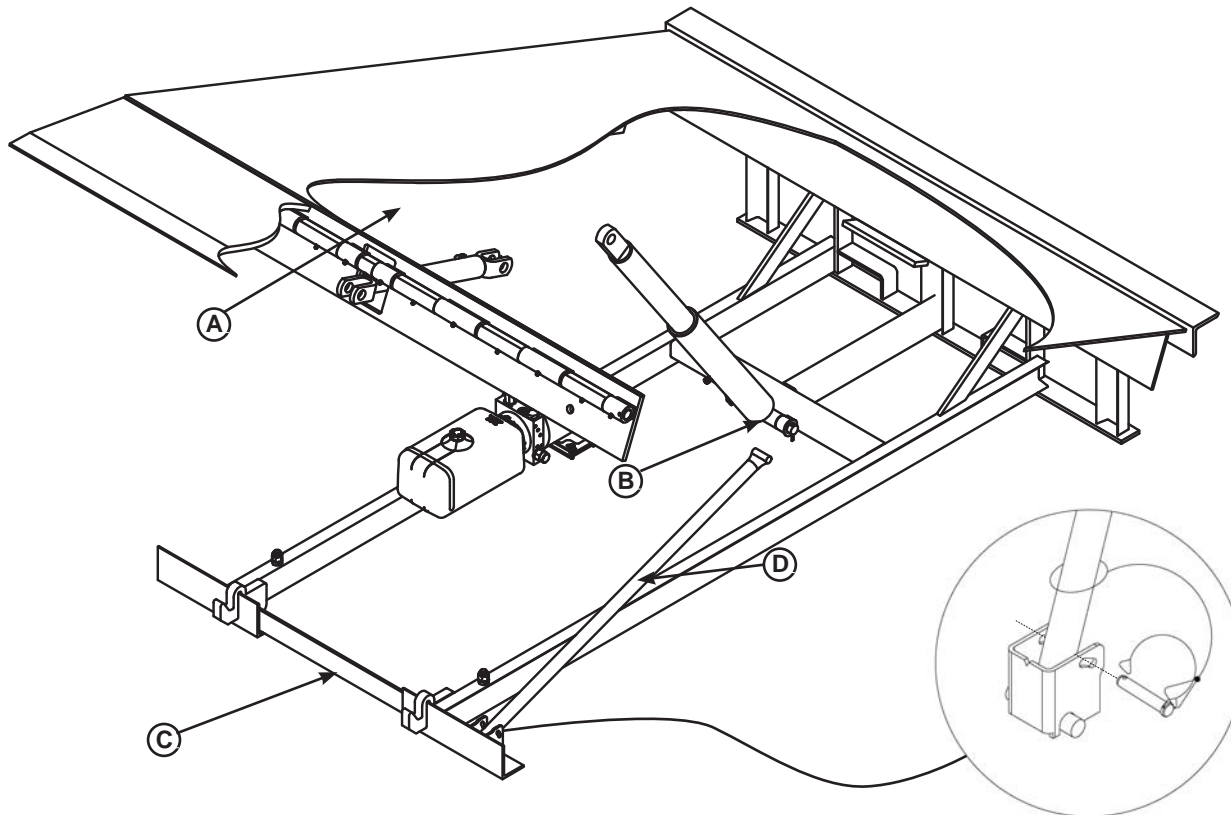

A— Platform Joists
B— Shim Locations (Under Platform Cylinder Trunnions)

C— Removable Frame Section
D— Maintenance Prop

14. Using an external lifting device (i.e., crane or fork truck) attached to the platform lifting brackets, slowly raise the platform. Check for binding as platform is being raised.
15. If binding occurs, lower the platform. Reposition leveler and/or add or remove shims as necessary. Slowly raise platform again. If platform still binds, contact Systems, Inc. Technical Services for further instructions.
16. All LHP models:
 - a. Install shims under maintenance prop (D) where prop attaches to leveler frame. Make sure prop is solidly shimmed.
 - b. Using the appropriate lifting device, attached to the platform lifting lugs, slowly raise the dock to the fully open position.

CAUTION

Two people are required to engage the maintenance prop: one person to operate the lifting device, the other person to engage the maintenance prop.

WARNING

DO NOT use the maintenance prop to support the raised platform until the maintenance prop has been properly shimmed and welded. The shims must be welded to each other, the leveler frame, and to the front pit curb steel. Failure to do this may result in serious personal injury or death.

- c. Raise maintenance prop (D) to the service (upright) position and lock prop in this position using an OSHA approved locking device.
- d. Proceed to step 18.



WARNING

Make sure the platform is properly supported in the raised position before entering the pit to finish weld the shims. Failure to do this may result in serious personal injury or death.

18. All model levelers: Install shims at locations (B) using the pyramid or stepped shimming method. Both platform cylinder trunnions must be solidly shimmed the entire length of the trunnion. Make sure the trunnions are level from side-to-side as well as from front-to-back.
19. Finish weld all shims using a fillet weld.
 - Weld all shims within each shim stack to each other, then weld the shim stack to the leveler frame.
 - Weld the front leveler frame shim stacks to the front pit curb steel.
20. When all welding has been completed, paint all the welds and shims.
21. For all LHP models, remove the Shipping Bar (C) by grinding the tack welds that hold it in place during transport. Paint after complete.

NOTE: LHP models are shipped with a front frame section (C) installed. This temporary frame holds the leveler frame at the correct dimensions until the leveler is permanently anchored into place. Only then should it be removed.

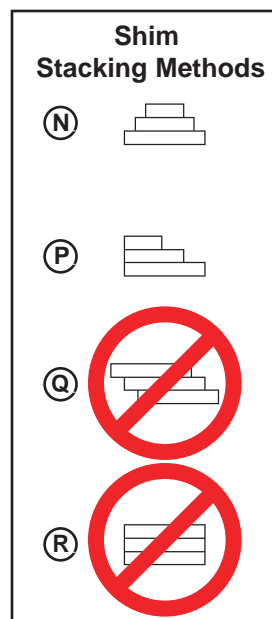

* For left/right orientation of dock leveler, see inside back cover of this manual.

INSTALLATION

Install Control Panel and Wiring

WARNING

The electrical power must be OFF prior to electrical installation. For maximum protection, use an OSHA approved locking device to lock out all power sources. Only the person installing the equipment should have the key to unlock the power source.

Failure to follow these instructions may result in serious personal injury or death.

WARNING

DO NOT make any final electrical connections until all welding has been completed. Failure to do this may result in serious personal injury or death.

CAUTION

All electrical work — including the installation of the disconnect panel, control panel, and final connections to the pit junction box — must be performed by a certified electrician and conform to all local and applicable national codes.

 **DANGER**



**Arc Flash and Shock Hazard
PPE (Personal Protection Equipment) Required**

De-energize equipment before working on or inside. Do not open cover without appropriate PPE. Refer to NFPA 70E for PPE requirements. This panel may contain more than one power source.

**Hazardous Voltage
Will Cause Severe
Injury or Death**

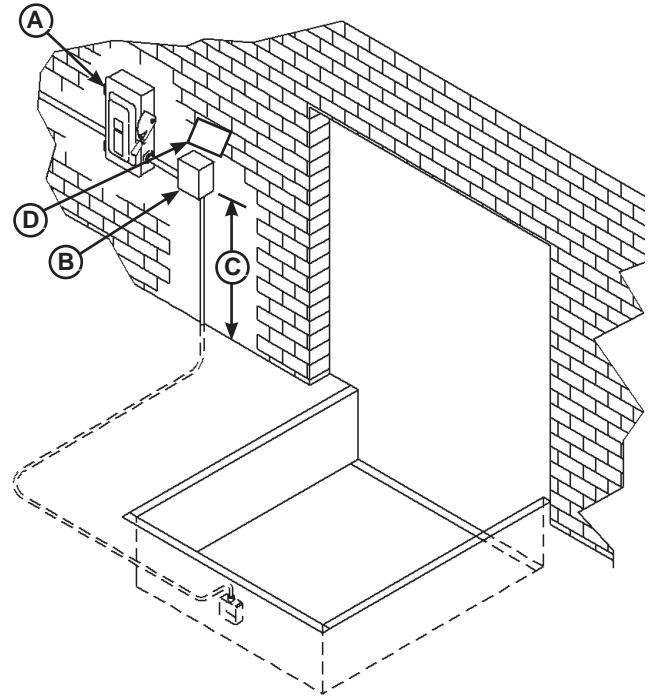

A— Disconnect Panel (provided by others)
B— Control Panel C— Distance, 48 in. (14 630 mm)
D— Placard

1. Mount the push button control panel (B) so bottom of control panel-to-dock floor distance (C) is 48 in. (1219.2 mm).
2. Install electrical disconnect panel (A) if not already installed.
3. Install and connect the control wiring.
4. Connect the dock leveler power cable to the outlet in the pit junction box. Refer to the electrical drawings supplied with the dock leveler.
5. After all electrical connections in the pit have been made, raise the leveler, disengage the maintenance prop and allow the platform to lower
6. Install the Placard(s) (D), in close proximity to the control box and in plain sight.

Put New Dock Leveler Into Service

1. Disconnect the external lifting device and chains from the lifting brackets.
2. Check that the leveler is flush with the dock floor and that the platform lip contacts both lip keepers evenly.

If an excessive transition exists between the dock floor and leveler and/or lip does not contact both lip keepers evenly, contact Systems, Inc. Technical Services for further instructions.

3. Install the dock bumpers as required.
4. Turn the main electrical power ON.



WARNING

Always stand clear of platform lip when working in front of the dock leveler. Serious personal injury or death may result.

5. Raise the leveler platform fully by pushing and holding the RAISE button .

NOTE: The platform of a properly operating dock leveler will automatically stop rising when it reaches its full raised height, at which point, the lip extends.

6. Release the RAISE button to lower the platform. As long as there is no truck present at the dock, the platform will lower to the full below-dock position as the lip folds.

NOTE: If a truck is present, the platform will lower until the lip rests on the transport vehicle. (See Operating Instructions in Operation section.)

7. When the platform lowers to the full below-dock position, wait 5 seconds after the lip has folded to allow lip cylinder to fully retract. Push and hold the RAISE button until the platform rises just enough to clear the lip keepers, then release the RAISE button to allow the platform to lower to the cross-traffic (stored) position (lip engages lip keepers).
8. Perform steps 5 – 7 at least four times to purge any air that may be in the hydraulic system and to ensure proper operation.



CAUTION

Unless the dock leveler is equipped with a tethered remote, two people are required to engage the maintenance prop: one person to operate the unit, the other person to engage the maintenance prop.

9. Raise the platform fully. Hold the platform at this position using the RAISE button and move the maintenance prop to the service (upright) position. Release the RAISE button to allow the platform to lower until it is resting on the maintenance prop.
10. With the maintenance prop supporting the platform, remove the lifting brackets and front shipping bar in between lip keepers.
11. Push and hold the RAISE button until the maintenance prop drops to its stored position. Release the RAISE button and allow the platform to lower fully.

OPERATION

Operating Instructions

DANGER

Stay clear of dock leveler when transport vehicle is entering or leaving dock area.

DO NOT move or use the dock leveler if anyone is under or in front of leveler.

Keep hands and feet clear of pinch points. Avoid putting any part of your body near moving parts.

Failure to follow these instructions may result in severe personal injury or death.

WARNING

Only trained personnel should operate the dock leveler.

DO NOT use a broken or damaged dock leveler. Make sure proper service and maintenance procedures have been performed on leveler before using.

Transport vehicle wheels must be chocked unless the truck restraint is used. Never remove the wheel chocks until loading/unloading is finished and truck driver has been given permission to leave.

Make sure platform lip rests on the transport vehicle bed with at least 4 in. (102 mm) of overlap.

Maintain a safe distance from side edges of leveler during the loading/unloading process.

Failure to follow these instructions may result in serious personal injury or death.

WARNING

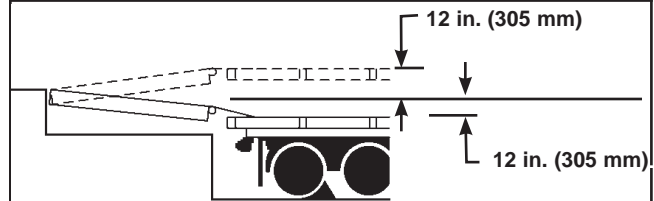

The LHP hydraulic dock leveler is designed to compensate for a maximum ± 12 in.* (305 mm) of height difference between the loading dock and the transport vehicle bed. DO NOT use the dock leveler if the transport vehicle bed is more than 12 in. (305 mm) higher or lower than the dock floor.

*service height may vary with design specifications

DO NOT overload the dock leveler.

DO NOT operate any equipment while under the influence of alcohol or drugs.

DO NOT leave equipment or material unattended on the dock leveler.

Failure to follow these instructions may result in personal injury and/or damage to equipment.

The dock leveler operating instructions are divided into the two methods of loading and unloading:

- **For ramp loading and unloading, see Ramp Loading/Unloading Instructions on page 21.**
- **For end loading and unloading, see End Loading/Unloading Instructions on page 22.**

Operating Instructions—Continued

Ramp Loading/Unloading Instructions

NOTE: If end unloading is required, see End Loading/Unloading Instructions on page 22.

For ramp loading or unloading, the LHP dock leveler can be operated by using the RAISE button on the control panel.

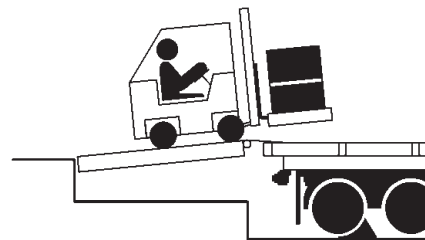

1. Check to make sure transport vehicle is positioned squarely against dock bumpers.
2. Instruct driver to remain at the dock until the loading or unloading process has been completed.
3. Chock the transport vehicle wheels or use the truck restraint if available.

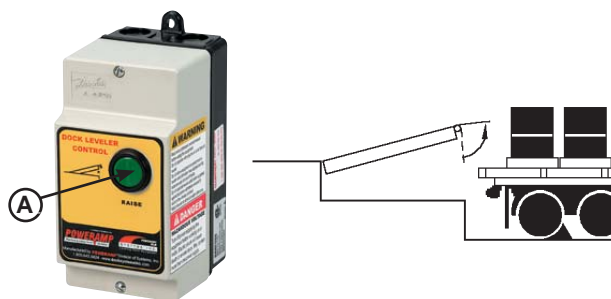

A—RAISE Button

4. Extend the platform lip onto transport vehicle as follows:
 - a. Raise the platform by pushing and holding RAISE button .
 - b. Hold the RAISE button until the lip is fully extended, then release the RAISE button. The platform will lower until the lip is resting on the transport vehicle bed.
 - c. Make sure that the lip is fully extended and supported on the transport vehicle along the entire width of the platform with at least 4 in. (102 mm) of lip contacting the transport vehicle bed.

5. Proceed with loading or unloading the transport vehicle.
6. If end loading is necessary, see End Loading/Unloading Instructions on page 22.

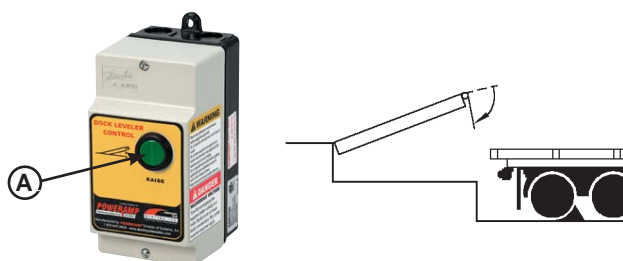

A—RAISE Button

7. When loading or unloading is finished, raise the platform by pushing and holding RAISE button (A) .

Hold the RAISE button until the lip folds enough to clear the transport vehicle bed, then release the RAISE button. The lip will fold and the platform will return to the cross-traffic position.

8. Remove chocks from transport vehicle wheels or release the truck restraint if used.
9. Indicate to driver that truck may leave the dock.

OPERATION

Operating Instructions—Continued

End Loading/Unloading Instructions

NOTE: If ramp loading is required, see Ramp Loading/Unloading Instructions on page 21.

End loading or unloading can be done with the dock at the cross-traffic position or below-dock position, depending on the height of the transport vehicle bed.

1. Check to make sure transport vehicle is positioned squarely against dock bumpers.
2. Instruct driver to remain at the dock until the loading or unloading process has been completed.
3. Chock the transport vehicle wheels or use the truck restraint if available.

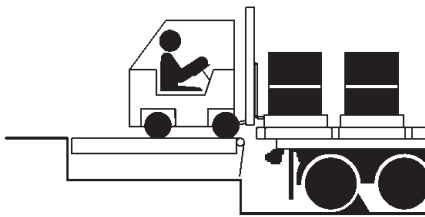

End Loading/Unloading — Platform at Cross-Traffic Position.

4. If transport vehicle bed is at or above dock floor level, leave leveler at the cross-traffic position and proceed with loading or unloading.

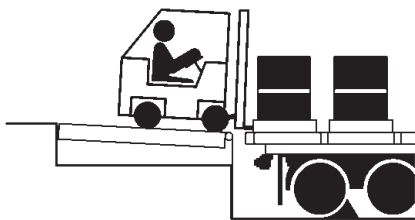

End Loading/Unloading — Platform at Below-Dock Position.

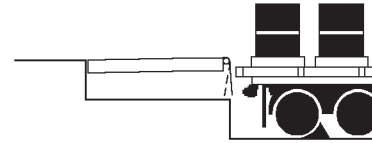

5. Push the Raise button (A) to the platform just enough to clear the lip keepers.
6. Proceed with loading or unloading.

NOTE: When end unloading is finished and access to the rest of the transport vehicle is still required, the platform lip will need to be extended. See Ramp Loading/Unloading Instructions on page 21 for further instructions.

7. When the loading or unloading is finished, return the dock leveler platform to the cross-traffic (stored) position by performing one of the following:

OR

- Push the Raise button (A) until the lip clears the lip keepers. Release Raise button, leveler will return to the stored or cross traffic position.
8. Remove chocks from transport vehicle wheels or release the truck restraint if used.
 9. Indicate to the driver that the truck may leave the dock.

Service Dock Leveler Safely

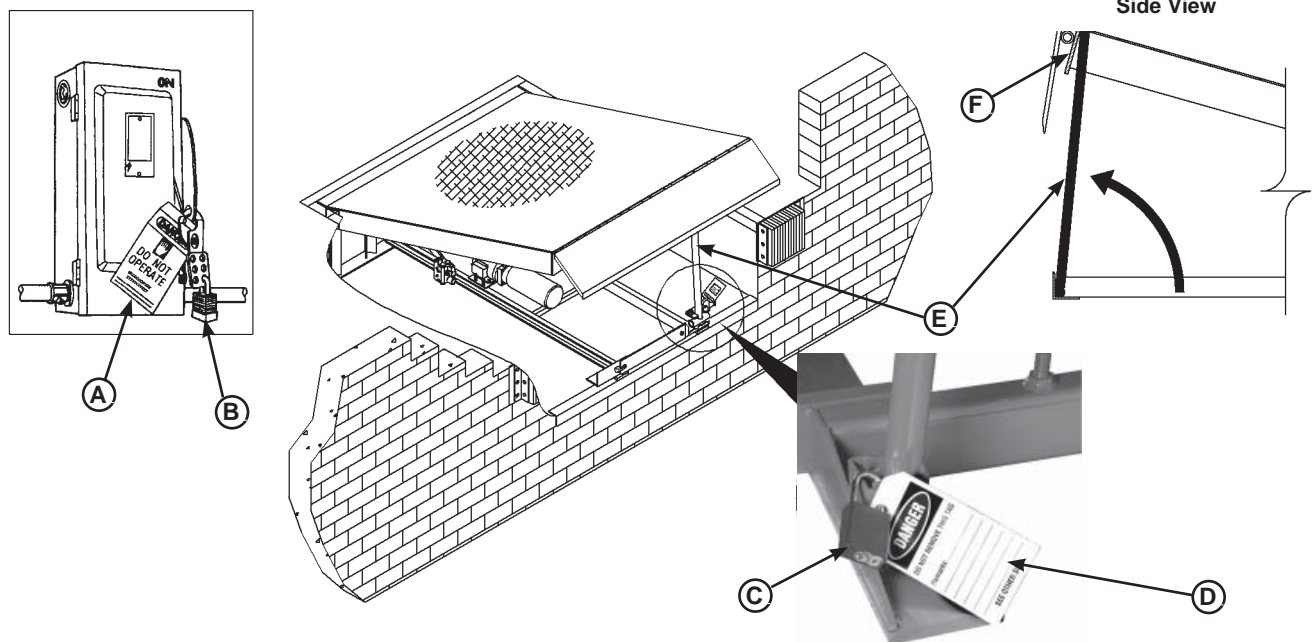

A— Tagout Device B— Lockout Device C— Lockout Device D— Tagout Device E— Maintenance Prop F— Header Plate

WARNING

When service under the dock leveler is required, always lock all electrical disconnects in the OFF position after raising the platform and engaging the maintenance prop. Failure to do this may result in serious personal injury or death.

WARNING

Always post safety warnings and barricade the work area at dock level and ground level to prevent unauthorized use of the dock leveler before maintenance is complete. Failure to do this may result in serious personal injury or death.

WARNING

Always stand clear of the dock leveler lip when working in front of the dock leveler.

The maintenance prop **MUST** be in the service position when working under the dock leveler. For maximum protection, use an OSHA approved locking device to lock the maintenance prop in the service position. Only the person servicing the equipment should have the key to unlock the maintenance prop.

Unless the dock leveler is equipped with a tethered remote, two people are required to engage the maintenance prop: one person to operate the unit, the other person to engage the maintenance prop.

Failure to follow these instructions may result in serious personal injury or death.

Whenever maintenance is to be performed under the dock leveler platform, support the platform with maintenance prop (E). Position the maintenance prop behind front header plate (F) while staying clear of the lip. The lip will fold down after the platform has rested on the maintenance prop. Lock the maintenance prop in the service (upright) position using an OSHA approved lockout device* (C) and tagout device* (D).

Whenever servicing the dock leveler, lock the electrical power disconnect in the OFF position. Use only an OSHA approved lockout device* (B) and tagout device (A).

Only the person servicing the equipment should have the capability to remove the lockout devices. The tagout devices* must inform that repairs are in process and clearly state who is responsible for the lockout condition.

* Refer to OSHA regulation 1910.147.

* Refer to OSHA regulation 1910.146

MAINTENANCE

Periodic Maintenance

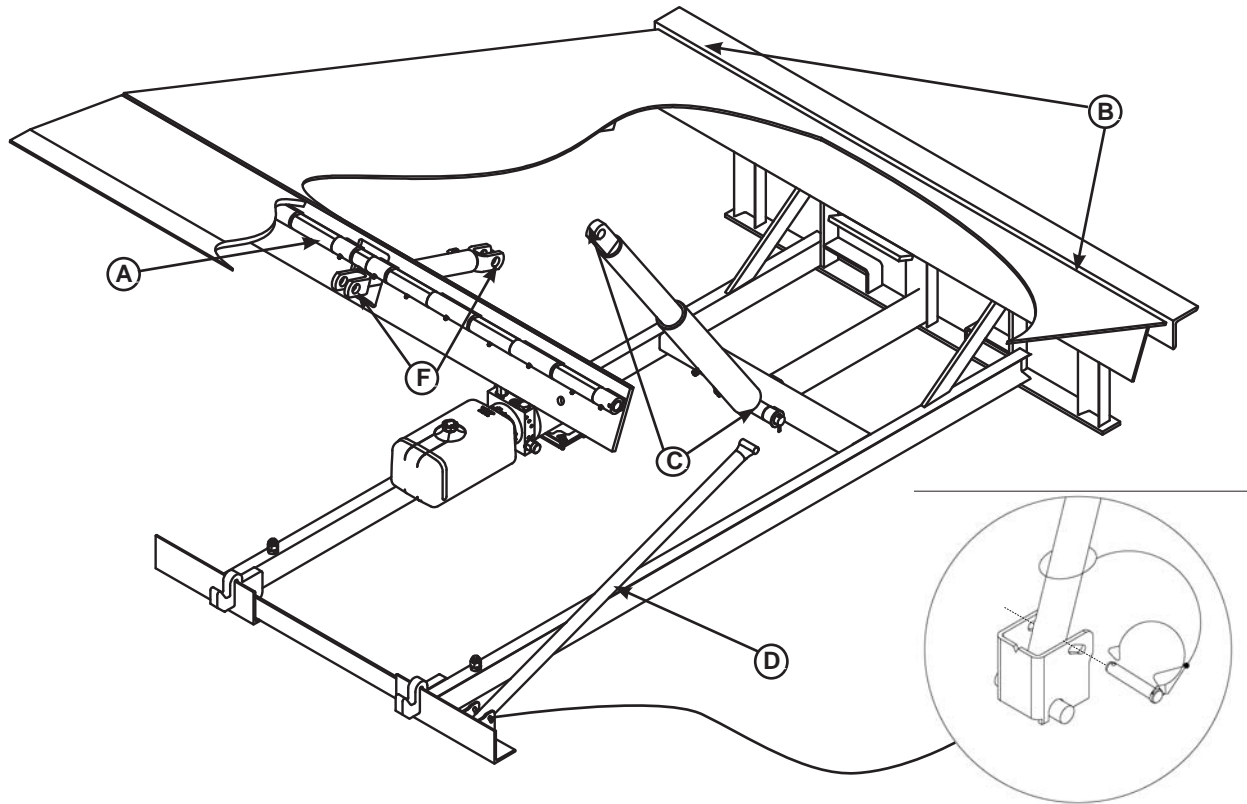

A— Lip Area
B— Platform Hinge Area

C— Main Cylinder Pins
D— Maintenance Prop Pivot

E— Lip Cylinder-to-Platform Pin

WARNING

Before performing any maintenance under the dock leveler, lock the electrical power source in OFF position and lock the maintenance prop in the service position using an approved locking device. (See Service Dock Leveler Safely in this section.)

Failure to follow these instructions may result in serious personal injury or death.

To ensure normal operation of the dock leveler, use only aircraft hydraulic fluid designed to meet or exceed military specification MIL-H-5606G. It is recommended that the following hydraulic fluids be used:

- ULTRA-VIS-HVI-15
- Aero Shell Fluid 4 or Fluid 41
- Mobile Aero HFA Mil-HS606A or Aero HF
- Texaco Aircraft Hydraulic Oil 15 or 5606
- Exxon Univis J13

IMPORTANT

Use of fluids that do not have equivalent specifications to those in the following list will result in abnormal operation of the dock leveler and voiding of warranty.

These fluid brands can be mixed together. Mixing with fluids that do not meet or exceed MIL-H-5606G may damage the equipment and WILL void warranty. Use of hydraulic fluids with equivalent specifications to those listed here are acceptable.

Regular maintenance must be performed on a weekly and quarterly schedule.

Follow All Safety Precautions

Weekly Maintenance

- Operate the dock leveler through the complete operating cycle to maintain lubrication.

NOTE: To thoroughly inspect the platform hinge area, put the platform in the full below-dock position.

- Inspect the platform hinge and the lip hinge areas. The hinge areas must be kept free of dirt and debris. Build-up of foreign material in the hinge areas will cause abnormal operation.

Quarterly Maintenance

- Weekly Maintenance

IMPORTANT

Failure to properly lubricate the dock leveler will cause abnormal operation of the leveler.

- Lubricate the following areas with light weight machine oil:

(B)(D)- Platform lug area (apply oil to top of all platform hinges when platform is at the full below-dock position)

- Lubricate the following areas with white lithium grease:

(A)— Lip hinge area (apply oil to each of lip and platform hinge when platform is at the full below-dock position and lip is folded)

(C)(E) - Both Hoist and Lip cylinder trunnions

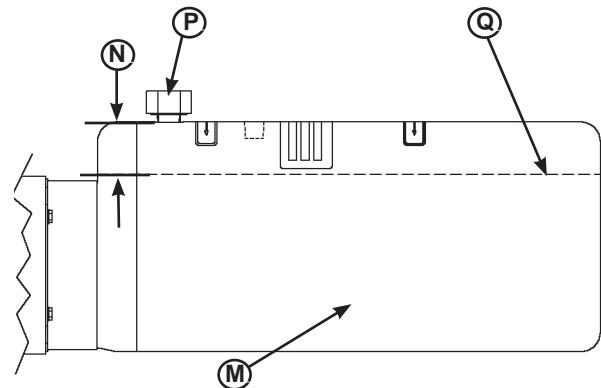

M -- Reservoir

N- 3 in. (76.5mm)

From Top of Reservoir

P - Breather Cap

Q - Fluid Level

IMPORTANT

A low fluid level or the use of hydraulic fluids not equivalent to the fluid types recommended, will cause abnormal operation of the leveler and WILL void warranty.

- Check reservoir fluid level (Q):

1. Put the dock leveler platform at the full above-dock position, engage prop.

2. Turn OFF all electrical power to the leveler.

WARNING

Before performing any maintenance under the dock leveler, lock the electrical power source in OFF position and lock the maintenance prop in the service position using an approved locking device. (See Service Dock Leveler Safely in this section.)

Failure to follow these instructions may result in serious personal injury or death.

3. Measure fluid level. The fluid level should be approximately 3 in. (76.5 mm) (N) from top of reservoir (M) with platform raised on the maintenance prop.

4. Add hydraulic fluid if necessary. Use only recommended fluid.

5. Turn ON electrical power to the leveler.

6. Return the platform to the cross-traffic position.

NOTES

This page intentionally left blank

Adjust Main Pressure Relief

WARNING

When service under the dock leveler is required, always lock all electrical disconnects in the OFF position after raising the platform and engaging the maintenance prop. Failure to do this may result in serious personal injury or death.

WARNING

Always post safety warnings and barricade the work area at dock level and ground level to prevent unauthorized use of the dock leveler before maintenance is complete. Failure to do this may result in serious personal injury or death.

WARNING

Always stand clear of the dock leveler lip when working in front of the dock leveler.

The maintenance prop **MUST** be in the service position when working under the dock leveler. For maximum protection, use an OSHA approved locking device to lock the maintenance prop in the service position. Only the person servicing the equipment should have the key to unlock the maintenance prop.

Unless the dock leveler is equipped with a tethered remote, two people are required to engage the maintenance prop: one person to operate the unit, the other person to engage the maintenance prop.

Failure to follow these instructions may result in serious personal injury or death.

NOTE: The main pressure relief may need to be increased if the platform does not rise or rises slowly and the system operates in pressure relief mode. See Troubleshooting section.

The main pressure relief may need to be decreased if the pump motor loads down when platform reaches the full raised position. See Troubleshooting section.

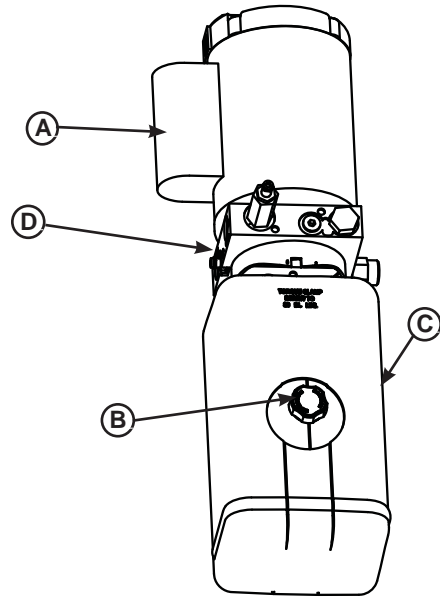

A— Motor C— Reservoir
B— Breather/Fill Cap D— Main Pressure Relief

To adjust the main pressure relief:

1. Raise the platform fully and engage the maintenance prop in the service position.
2. Turn OFF all electrical power to the dock leveler. Attach safety lockout and tagout devices.
3. Loosen locking nut.
4. Adjust hex adjusting screw in small 1/4 turn increments as follows:
 - Turn clockwise to increase pressure relief.
 - Turn counterclockwise to decrease pressure relief.
5. Tighten the jam nut.
6. Turn ON electrical power to the dock leveler.
7. Disengage the maintenance prop.
8. Check leveler operation.
9. Repeat steps 1– 8 as necessary.

ADJUSTMENTS

Adjust Lip Function

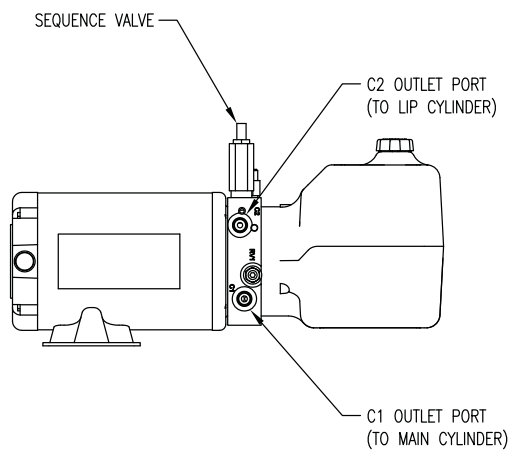
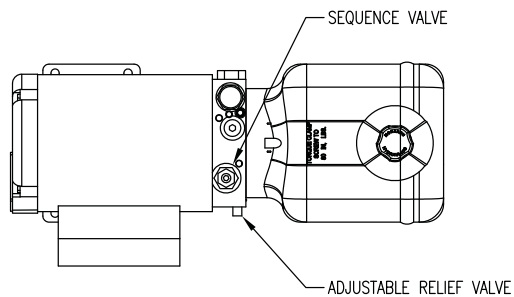

NOTES:

1. RELIEF VALVE IS FACTORY SET AT 1500 PSI. THIS VALVE IS MAIN SYSTEM RELIEF.
2. RELIEF VALVE ADJUSTMENT:
 - A. LOOSEN JAM NUT.
 - B. TURN SCREW CLOCKWISE TO INCREASE PRESSURE.
 - C. TURN SCREW COUNTER CLOCKWISE TO DECREASE PRESSURE.
 - D. TIGHTEN JAM NUT.
3. SEQUENCE VALVE IS FACTORY SET AT 750 PSI. TURN CLOCKWISE TO INCREASE PRESSURE, TURN COUNTER CLOCKWISE TO DECREASE PRESSURE. THIS VALVE NORMALLY SHOULD NOT NEED ADJUSTMENT.
4. SEE TROUBLESHOOTING SECTION FOR FURTHER ADJUSTMENT PROCEDURES.

TROUBLESHOOTING:

1. IF LIP OPENS AS PLATFORM BEGINS TO RISE, TURN SEQUENCE VALVE CLOCKWISE IN $\frac{1}{4}$ TURN INCREMENTS.
2. IF LIP WILL NOT FULLY RETRACT WHEN RECYCLING PLATFORM TO STORED POSITION, TURN SEQUENCE VALVE CLOCKWISE IN $\frac{1}{8}$ TURN INCREMENTS.

NOTE: ALL ADJUSTMENTS SHOULD BE MADE IN SMALL INCREMENTS, AND SHOULD BE CHARTED TO HAVE RELIABLE INFORMATION WHEN BACK TRACKING THROUGH ADJUSTMENTS.



WARNING

When service under the dock leveler is required, always lock all electrical disconnects in the OFF position after raising the platform and engaging the maintenance prop. Failure to do this may result in serious personal injury or death.



WARNING

Always post safety warnings and barricade the work area at dock level and ground level to prevent unauthorized use of the dock leveler before maintenance is complete. Failure to do this may result in serious personal injury or death.



WARNING

Always stand clear of the dock leveler lip when working in front of the dock leveler.

The maintenance prop **MUST** be in the service position when working under the dock leveler. For maximum protection, use an OSHA approved locking device to lock the maintenance prop in the service position. Only the person servicing the equipment should have the key to unlock the maintenance prop.

Unless the dock leveler is equipped with a tethered remote, two people are required to engage the maintenance prop: one person to operate the unit, the other person to engage the maintenance prop.

Failure to follow these instructions may result in serious personal injury or death.

1. Raise platform fully and engage the maintenance prop in the service position. Allow platform to rest on the prop so the lip will fully fold until it contacts the lip stops.
2. Turn OFF all electrical power to the dock leveler. Attach safety lockout and tagout devices.

PARTS

Electrical Components

TABLE 1 TOTAL FLA		TABLE 2 MOTOR NAMEPLATE DATA MOTOR LOCATED AT DOCK LEVELER		
VOLTAGE	FLA	VOLTAGE	FLA	HP
115 V	14.5 A	115 V	14.4 A	1.25 HP
230 V	7.2 A	230 V	7.2 A </tr	

TABLE 3	
SEE NAMEPLATES ON CONTACTOR & OVERLOAD RELAY FOR:	
1.	TYPE OF FIELD WIRING CONDUCTORS.
2.	TEMPERATURE RATING OF FIELD WIRING CONDUCTORS.
3.	TERMINAL TIGHTENING TORQUE.
4.	TYPE OF BRANCH CIRCUIT FUSE.
5.	MAXIMUM RATING OF BRANCH CIRCUIT FUSE.
6.	SHORT CIRCUIT CURRENT RATING.

NOTE

1. ALL WIRES BY OTHERS UNLESS INDICATED OTHERWISE.
2. ALL CONDUIT BY OTHERS UNLESS INDICATED OTHERWISE.
3. ALL WIRE CONNECTIONS BY OTHERS.
4. ● REPRESENTS WIRE NUT OR EQUIVALENT. BY OTHERS.

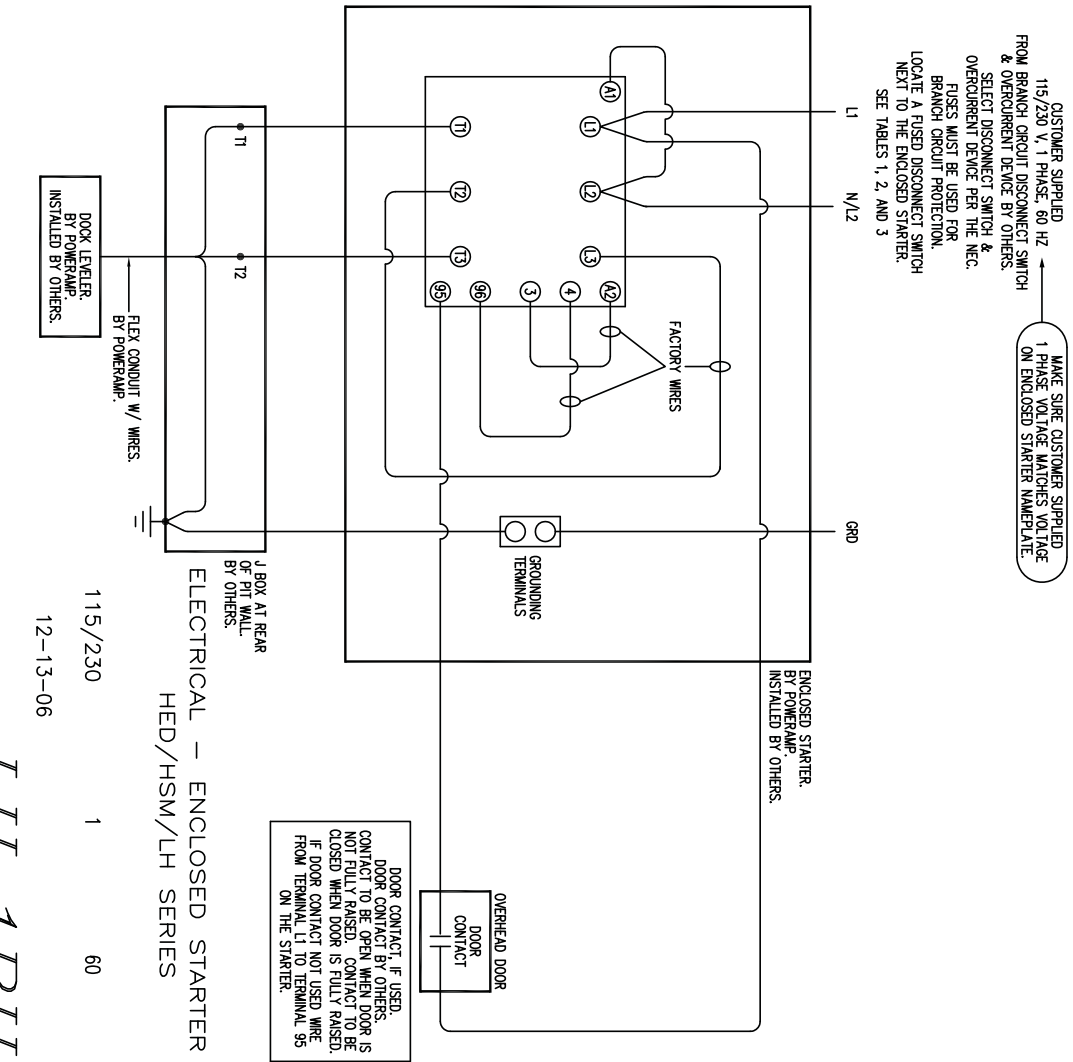

* Provide dock leveler serial number, voltage, phase, and options when calling or faxing controller orders.

LH 1PH

Electrical Components

MAKE SURE CUSTOMER SUPPLIED 3 PHASE VOLTAGE MATCHES VOLTAGE ON ENCLOSED STARTER NAMEPLATE.

CUSTOMER SUPPLIED 230/460 V, 3 PHASE, 60 HZ FROM BRANCH CIRCUIT DISCONNECT SWITCH & OVERCURRENT DEVICE BY OTHERS. SELECT DISCONNECT SWITCH & OVERCURRENT DEVICE PER THE NEC. FUSES MUST BE USED FOR BRANCH CIRCUIT PROTECTION. LOCATE A FUSED DISCONNECT SWITCH NEXT TO THE ENCLOSED STARTER. SEE TABLES 1, 2, AND 2

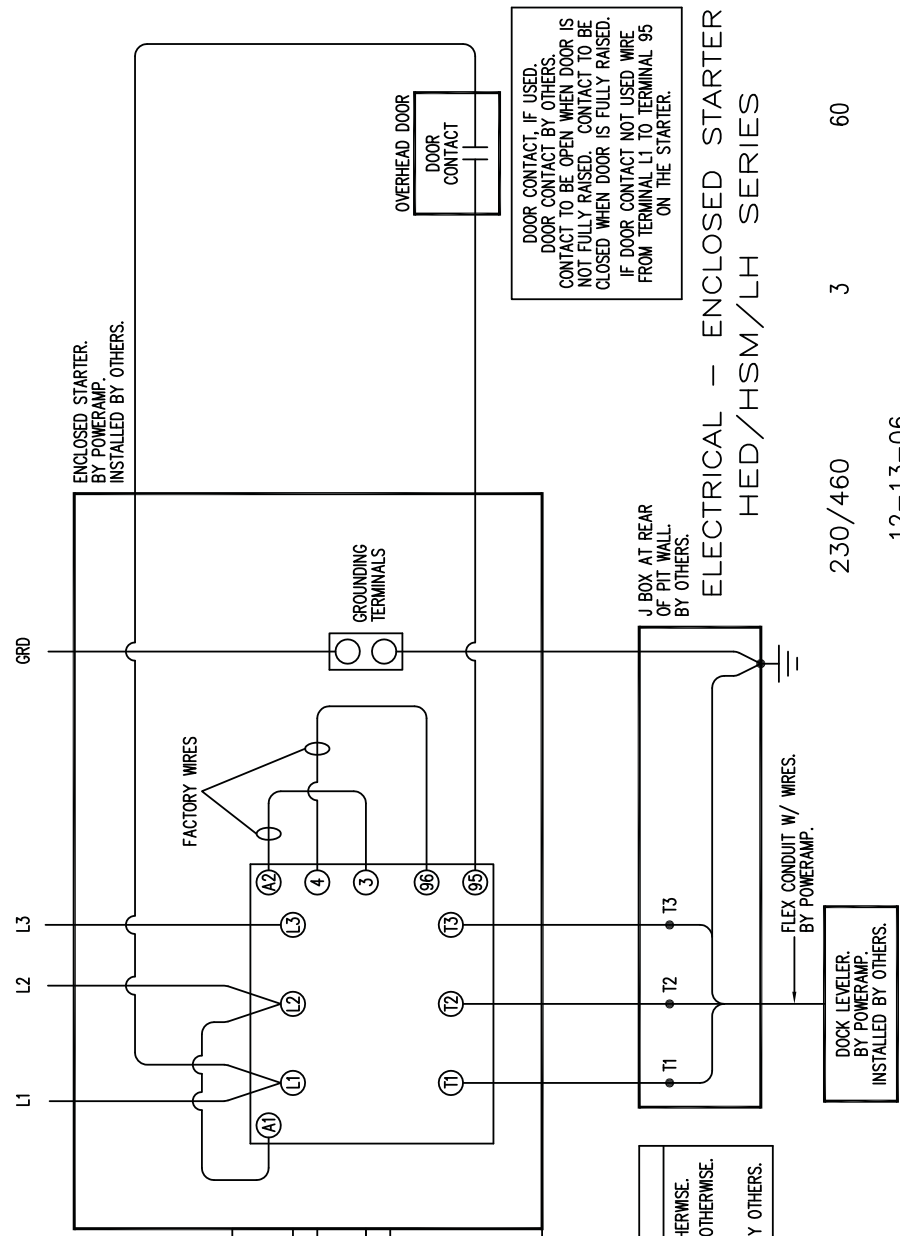

ENCLOSED STARTER. BY POWERAMP. INSTALLED BY OTHERS.

DOOR CONTACT, IF USED. DOOR CONTACT BY OTHERS. CONTACT TO BE OPEN WHEN DOOR IS NOT FULLY RAISED. CONTACT TO BE CLOSED WHEN DOOR IS FULLY RAISED. IF DOOR CONTACT NOT USED WIRE FROM TERMINAL L1 TO TERMINAL 95 ON THE STARTER.

- NOTE
1. ALL WIRES BY OTHERS UNLESS INDICATED OTHERWISE.
 2. ALL CONDUIT BY OTHERS UNLESS INDICATED OTHERWISE.
 3. ALL WIRE CONNECTIONS BY OTHERS.
 4. ● REPRESENTS WIRE NUT OR EQUIVALENT. BY OTHERS.

TABLE 1

TOTAL FLA	FLA	HP
3.6 A	3.6 A	1.25 HP
1.8 A	1.8 A	

TABLE 2

MOTOR NAMEPLATE DATA	MOTOR LOCATED AT DOCK LEVELER
VOLTAGE	FLA
230 V	3.6 A
460 V	1.8 A

TABLE 3

SEE NAMEPLATES ON CONTACTOR & OVERLOAD RELAY FOR:
1. TYPE OF FIELD WIRING CONDUCTORS.
2. TEMPERATURE RATING OF FIELD WIRING CONDUCTORS.
3. TERMINAL TIGHTENING TORQUE.
4. TYPE OF BRANCH CIRCUIT FUSE.
5. MAXIMUM RATING OF BRANCH CIRCUIT FUSE.
6. SHORT CIRCUIT CURRENT RATING.

ELECTRICAL – ENCLOSED STARTER
HED/HSM/LH SERIES

230/460 3 60

12-13-06

LH 3PH

DOCK LEVELER. BY POWERAMP. INSTALLED BY OTHERS.

FLEX CONDUIT W/ WIRES. BY POWERAMP.

J BOX AT REAR OF PIT WALL. BY OTHERS.

PARTS

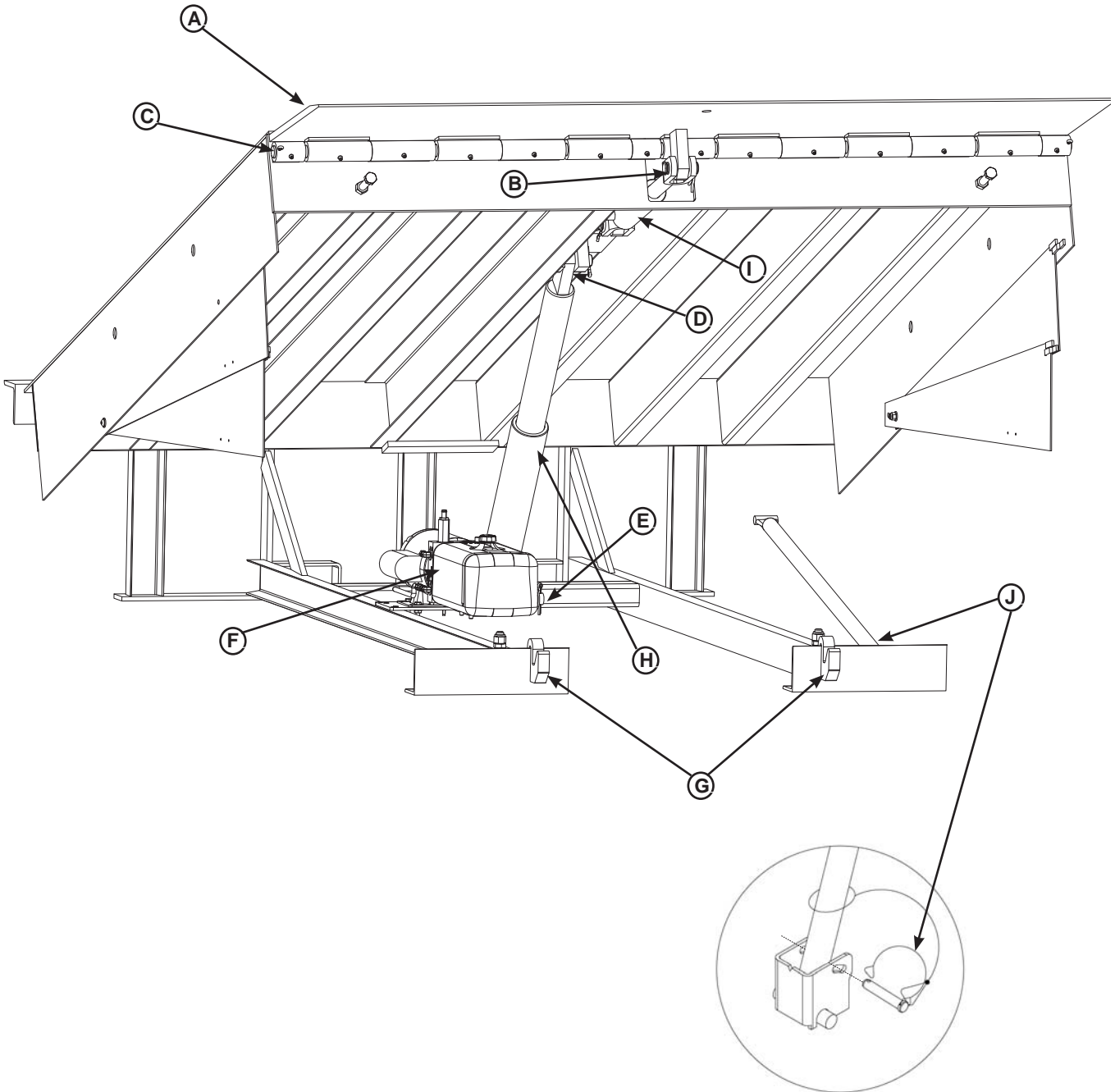

LIPS					
ITEM	QTY	25K	35K	40K	
A	1	6.0 FOOT			
		16	DLIP-1250	DLIP-1256	DLIP-1259
		18	DLIP-1251	DLIP-1257	DLIP-1260
		20	DLIP-1252	DLIP-1258	DLIP-1261
	1	6.5 FOOT			
		16	DLIP-1262	DLIP-1268	DLIP-1271
		18	DLIP-1263	DLIP-1269	DLIP-1272
		20	DLIP-1264	DLIP-1270	DLIP-1273
	1	7.0 FOOT			
		16	DLIP-1274	DLIP-1280	DLIP-1283
		18	DLIP-1275	DLIP-1281	DLIP-1284
		20	DLIP-1276	DLIP-1282	DLIP-1285
B	2	113-264	PIN, LIP CYL		
C	2	DPLA-2101	6.0 FOOT LIP SHAFT		
		DPLA-2102	6.5 FOOT LIP SHAFT		
		DPLA-2103	7.0 FOOT LIP SHAFT		
D	1	DPLA-0389	PIN HOIST UPPER		
E	1	DFRA-1205	PIN HOIST LOWER		
F	1	DOTH-2854	POWER PACK 1PH		
		DOTH-2855	POWER PACK 3PH		
G	2	8432-0983	KEEPER LIP 16		
		8432-0984	KEEPER LIP 18		
		8432-0985	KEEPER LIP 20		
		8432-0986	KEEPER LIP 16 (24 PIT)		
		8432-0987	KEEPER LIP 18 (24 PIT)		
		8432-0988	KEEPER LIP 20 (24 PIT)		
H	1	DOTH-2853	MAIN CYLINDER		
I	1	DOTH-2852	LIP CYLINDER		

PARTS

Hydraulic Components

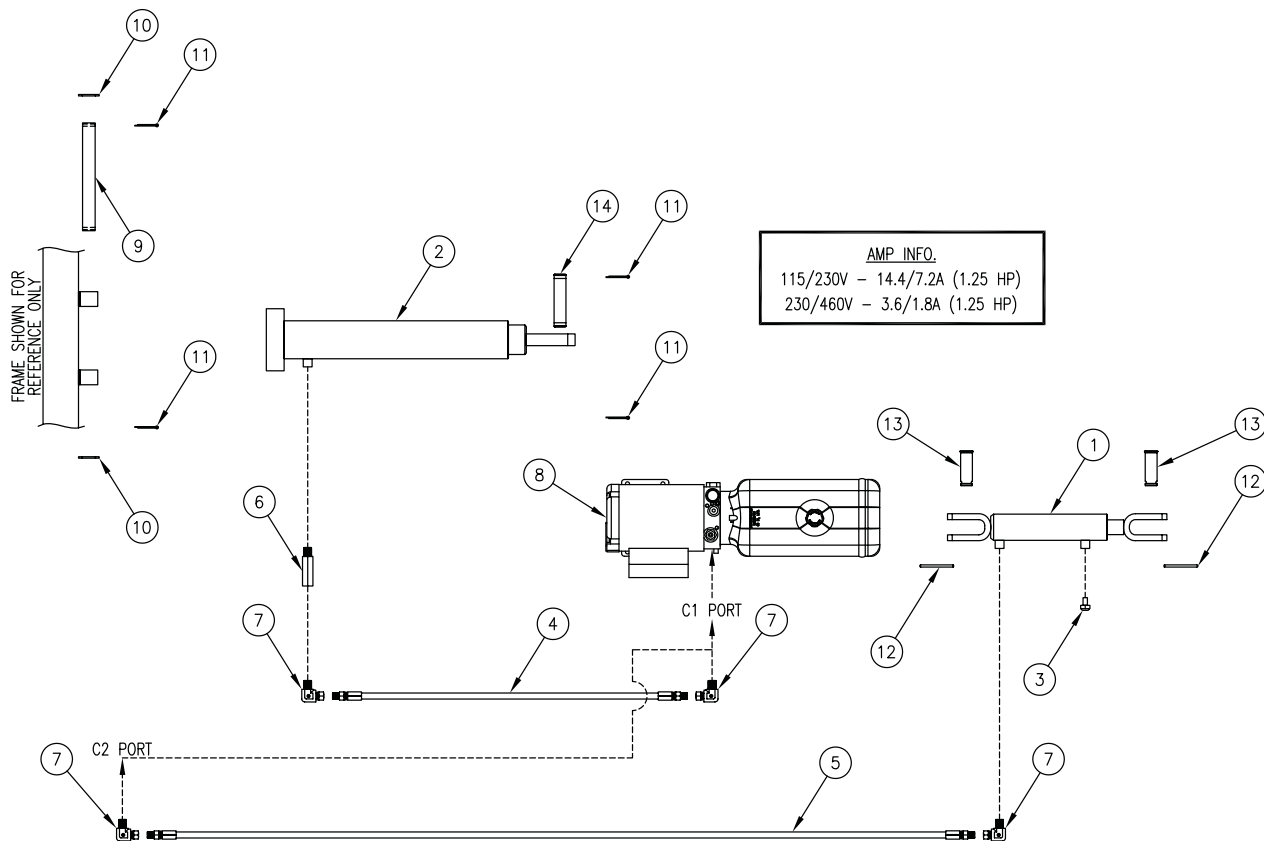

BILL OF MATERIAL

ITEM	QTY	PART NO.	DESCRIPTION	SIZE
1	1	DOTH-2852	CYLINDER - LIP	2" BORE X 6" STROKE
2	1	DOTH-2853	CYLINDER - MAIN HOIST	3" BORE X 14" STROKE RAM
3	1	DOTH-2814	BREATHER VENT PLUG	3/8" MALE - NPT
4	1	DOTH-2792	HOSE ASSEMBLY (MAIN)	1/4 X 30 OL (R-S)
5	1	DOTH-2798	HOSE ASSEMBLY (LIP)	1/4 X 70 OL (R-S)
6	1	DOTH-2771	VELOCITY FUSE - 3 GPM	
7	4	DOTH-2739	90 DEG. SWIVEL - 3/8M X 1/4F	
8	1	DOTH-2854	PPAC - MONARCH - NEUTRON	115V/230V - 1 PHASE - 60 HERTZ
	1	DOTH-2855	PPAC - MONARCH - NEUTRON	230V/460V - 3 PHASE - 60 HERTZ
	1	DOTH-2856	PPAC - MONARCH - NEUTRON	110V/220V - 1 PHASE - 50 HERTZ
	1	DOTH-2857	PPAC - MONARCH - NEUTRON	208V/380V - 3 PHASE - 50 HERTZ
9	1	DFRA-1205	PIVOT PIN	1 OD X 9-1/8
10	2	DOTH-2205	WASHER	1-3/4 OD X 1-1/8 ID X 1/8
11	2	DOTH-2382	PIN, COTTER	1/4 X 2
12	2	DOTH-2815	PIN - HITCH CLIP	
13	2	DOTH-2816	PIN - CLEVIS	1 X 3
14	1	DPLA-0389	PIN - MAIN HOIST	1 X 4-1/2
15	1	7141-0216	CONTROL BOX - DANFOSS	115V/1PH (NOT SHOWN)
	1	7141-0217	CONTROL BOX - DANFOSS	460V/3PH (NOT SHOWN)
	1	7141-0218	CONTROL BOX - DANFOSS	208V/1PH (NOT SHOWN)
	1	7141-0219	CONTROL BOX - DANFOSS	230V/1PH (NOT SHOWN)
	1	7141-0220	CONTROL BOX - DANFOSS	208V/3PH (NOT SHOWN)
	1	7141-0221	CONTROL BOX - DANFOSS	230V/3PH (NOT SHOWN)

This page intentionally left blank

Toe Guard / Weather Seal Options

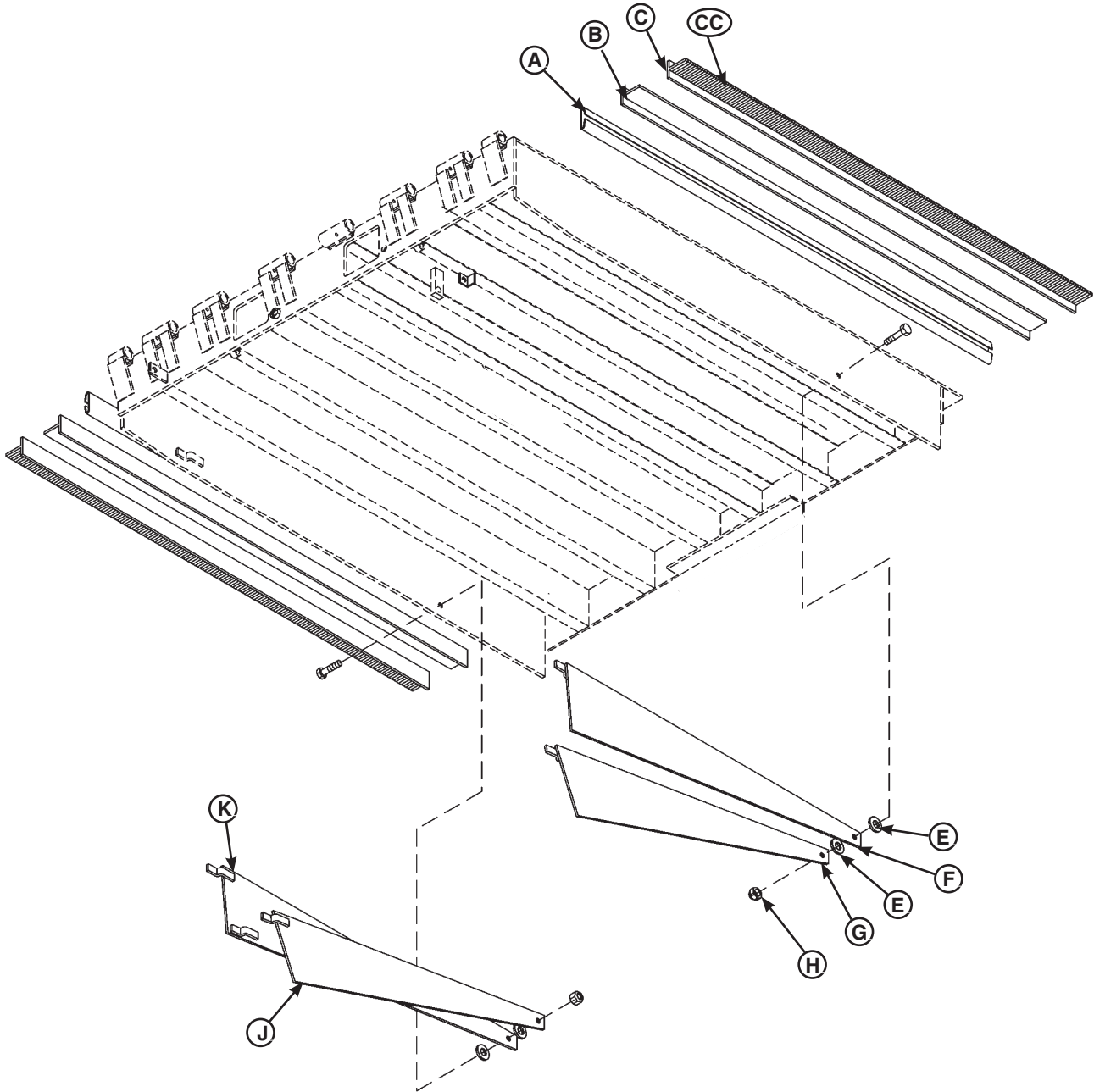

AR = As Required

NOTE: Brush or track can be purchased separately as replacement parts. Contact factory for part numbers.

Kits provide all parts / hardware to add Toe Guards or Weather Seal to an existing dock leveler.

Weatherseal channel must be welded to leveler

*Note, see Safety section (P.4). Pay special attention to removing grounds to motor and control box before welding.

* Provide dock leveler serial number and size of platform when calling or faxing orders.

Weather Seal, Brush Style

Item	Quantity	Part Number	Description
A	2	DOTH-2818	Channel, Weather Seal, 84"
B	2	DOTH-2824	T-Rubber, Weather Seal, 84"
C	2	DOTH-2820	Extrusion, Brush Weather Seal, 84"
CC	2	DOTH-2822	Brush Weather Seal, 1.58" x 84"
D	2	DOTH-2041	Cap Screw
E	4	DOTH-2207	Washer
F	1	See * Below	Toe Guard
G	1	See * Below	Toe Guard
H	2	DOTH-2131	Nut, Nylon Lock
J	1	See * Below	Toe Guard
K	1	See * Below	Toe Guard

Item	Quantity	Part Number	Description
Toe Guard / Weather Seal Options			
A	1	DOTH-2842	Track, Weatherstrip, 5'
		DOTH-2819	Track, Weatherstrip, 6'
		DOTH-2187	Track, Weatherstrip, 8'
		DOTH-2843	Track, Weatherstrip, 10'
C	1	DOTH-2850	Extrusion For Brush, 5'
		DOTH-2821	Extrusion For Brush, 6'
		DOTH-2820	Extrusion For Brush, 8'
		DOTH-2851	Extrusion For Brush, 10'
*	1	DKIT-9178	Full Range Toe Guard Assembly, 5'
		DKIT-9179	Full Range Toe Guard Assembly, 6'
		DKIT-9180	Full Range Toe Guard Assembly, 8'
		DKIT-9181	Full Range Toe Guard Assembly, 10'

Control Box

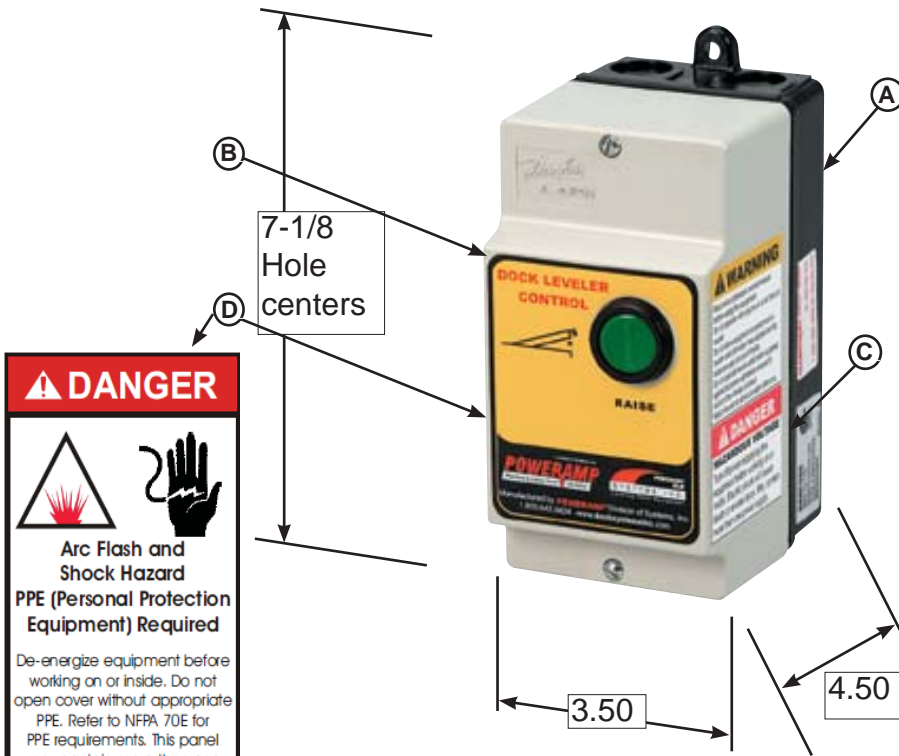

⚠ DANGER

Arc Flash and Shock Hazard
PPE (Personal Protection Equipment) Required

De-energize equipment before working on or inside. Do not open cover without appropriate PPE. Refer to NFPA 70E for PPE requirements. This panel may contain more than one power source.

Hazardous Voltage Will Cause Severe Injury or Death

⚠ DANGER	OPERATING INSTRUCTIONS
<ul style="list-style-type: none"> Read and follow all instructions, warnings and maintenance schedules in the manual and on placards. Operation and servicing of dock leveler is restricted to trained personnel. 	<p>POWERED DOCK LEVELERS</p> <p>NORMAL OPERATION</p> <ol style="list-style-type: none"> 1 Raise the platform by depressing and holding the RAISE button. 2 Hold the RAISE button until the lip is fully extended, then release the RAISE button. The platform will lower until lip is resting on the transport vehicle.
<ul style="list-style-type: none"> Always chock transport vehicle wheels or engage vehicle restraint and set parking brakes before operating dock leveler or beginning to load or unload. Before activating dock leveler, ensure lip avoids contact with transport vehicle sides and cargo. If lip does not lower to transport vehicle bed, reposition transport vehicle. Ensure the transport vehicle floor supports extended lip or the leveler frame (lip keepers or below dock endload supports) supports the ramp before driving on ramp. Stay clear of hinges and front and sides of moving dock leveler. Never use hands or equipment to move the ramp or lip. Never use damaged or malfunctioning dock leveler. Report problems immediately to supervisor. Always store dock leveler and remove people, material, and equipment from ramp before vehicle leaves the dock. DO NOT ENTER PIT unless dock leveler is securely supported by the maintenance prop. Disconnect power and follow proper lockout/tagout procedures for the dock leveler before entering the dock leveler pit or doing any repair or inspection under the dock leveler. <p>FAILURE TO FOLLOW THESE INSTRUCTIONS COULD RESULT IN DEATH OR OTHER SERIOUS INJURY.</p>	<p>STORING LEVELER</p> <ol style="list-style-type: none"> 1 Depress the RAISE button until the lip is completely folded. When the lip is folded release the RAISE button. The platform will lower returning to the cross-traffic position. <p>BELOW DOCK ENLOADING</p> <ul style="list-style-type: none"> (HYDRAULIC ONLY) Depress and hold the RAISE button until the lever is fully raised. As the lip starts to extend, release the RAISE button. The leverer will lower to the below dock position provided the lip extension allows the lip to clear the lip keepers. (AIR POWERED ONLY) Depress and hold the RAISE button until the leverer is 12" above dock level. Pull the below dock level chain until the leverer passes the below dock position. (HYDRAULIC WITH INFINITE LIP CONTROL) If equipped raise the platform by depressing and holding the RAISE button. When the lip is just above the lip keepers, simultaneously depress and hold the RAISE button and the LIP OUT button until lip has extended beyond the lip keepers. Release both buttons.
<p>1.262.255.1510 or 1.800.643.5424</p> <p>Call for additional placards, or manuals, or with questions regarding proper use, maintenance, and repair of dock leveler.</p> <p>www.DockSystemsInc.com</p> <p><small>POWERAMP HYDRAULIC DLM SYSTEMS, INC. Loading Dock Equipment</small></p>	<p><small>1751-0874</small></p> <p><small>NOTE: If equipped, depressing E-STOP button will stop platform from lowering</small></p>

Item	Quantity	Part Number	Description
A	1	7141-0216	Push Button Controller,
B	1	1751-0247	Decal (English)
C	1	1751-0477	Decal (English)
D	1	1751-0736	Decal Arc Flash
E	1	1751-0878	Placard,

This page intentionally left blank

This page intentionally left blank

MISCELLANEOUS

Customer Information

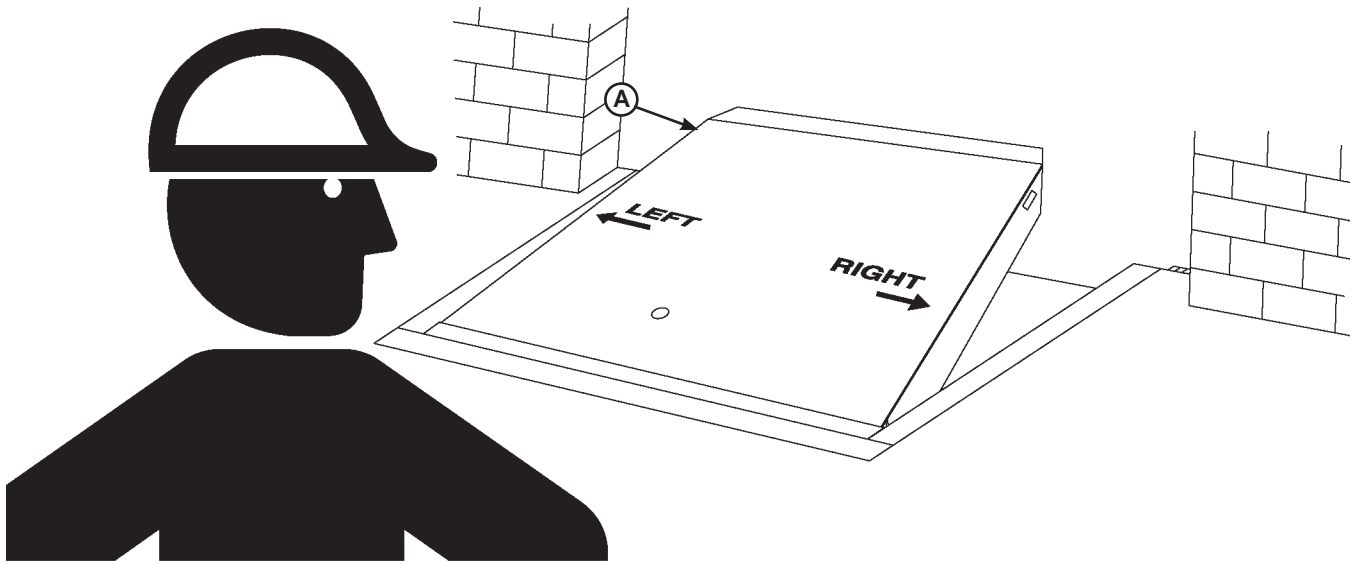

NOTE: Refer to illustration for left/right orientation of dock leveler.

The model/serial number decal (A) is located on the right platform joist near the front (lip) of dock leveler.

When you receive your LHP dock leveler, write down the dock leveler model and serial number in the form provided. This will help ensure safe keeping of the numbers in the event the model/serial number decal (A) becomes lost or damaged.

Also, write down Systems, Inc.'s job number, the company that installed the dock leveler, and the original owner's name. This will all help to identify the specific dock leveler if more information is required.

When ordering, use part numbers and description to help identify the item ordered. Do not use "item" numbers. These are only for locating the position of the parts. Always give dock leveler MODEL NUMBER and/or SERIAL NUMBER.

For service, call or contact:

Systems, Inc.
P.O. Box 309
Germantown, WI 53022

Phone: (800) 643-5424
Fax: (262) 255-5917

Dock Leveler Information	
Model	_____
Serial No.	_____
Systems, Inc., Job No.	_____
Original Owner Information	
Name	_____
Address	_____ _____
Installer Information	
Name	_____
Address	_____ _____
Date of Installation	_____

STANDARD PRODUCT WARRANTY

SYSTEMS, INC. warrants that its products will be free from defects in design, materials and workmanship for a period of one (1) year from the date of shipment. All claims for breach of this warranty must be made within 30 days after the defect is or can with reasonable care, be detected. In no event shall any claim be made more than 30 days after this warranty has expired. In order to be entitled to the benefits of this warranty, the product must have been properly installed, maintained and operated in accordance with all manufacturer's recommendations and/or specified design parameters and not otherwise have been subject to abuse, misuse, misapplication, acts of nature, overloading, unauthorized repair or modification, application in a corrosive environment or lack of maintenance. Periodic lubrication, adjustment and inspection in accordance with all manufacturers' recommendations are the sole responsibility of the Owner/ User.

In the event of a defect, as determined by SYSTEMS INC., covered by this warranty, SYSTEMS INC. shall remedy such defect by repairing or replacing any defective equipment or parts, bearing the cost for the parts, labor and transportation. This shall be exclusive remedy for all claims whether based on contract, negligence or strict liability.

WARRANTY LIMITATIONS

THE ABOVE WARRANTIES ARE IN LIEU OF ANY OTHER WARRANTIES, WHETHER EXPRESSED OR IMPLIED, INCLUDING BUT NOT LIMITED TO ANY IMPLIED WARRANTY OF MERCHANTABILITY OR FITNESS FOR A PARTICULAR PURPOSE. SYSTEMS INC. AND ITS SUBSIDIARIES SHALL NOT IN ANY EVENT BE LIABLE TO ANYONE, INCLUDING THIRD PARTIES, FOR INCIDENTAL, CONSEQUENTIAL OR SPECIAL DAMAGES OF ANY KIND INCLUDING BUT NOT LIMITED TO, BREACH OF WARRANTY, LOSS OF USE, LOSS OF PROFIT, INTERRUPTION OF BUSINESS OR LOSS OF GOODWILL.