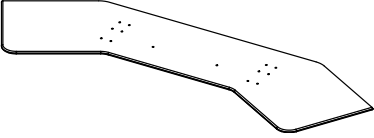
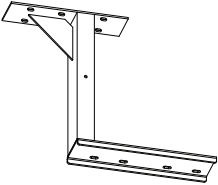
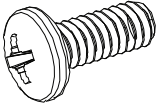
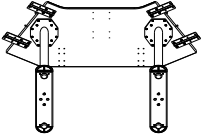

## Instructions for Assembling Second Tier

### Included Parts with the Second Tier - BOX 4

|   |                                       |                   |
|---|---------------------------------------|-------------------|
|     | <p>2nd Tier Platform</p>              | <p><b>x1</b></p>  |
|   | <p>2nd Tier Mounting Bracket</p>      | <p><b>x2</b></p>  |
|  | <p>1/4 - 20 x 5/8" Pan Head Screw</p> | <p><b>x28</b></p> |

### Additional Parts Needed from other boxes - BOX 1 & 2

|   |   |                  |
|---|---|------------------|
|  | <p>Assembled core table with legs (Instructions for assembling core table and legs are included in box 1 &amp; 2)</p> | <p><b>x1</b></p> |
|---|---|------------------|

# ULTIMATE SUPPORT®

2nd Tier Mounting Bracket

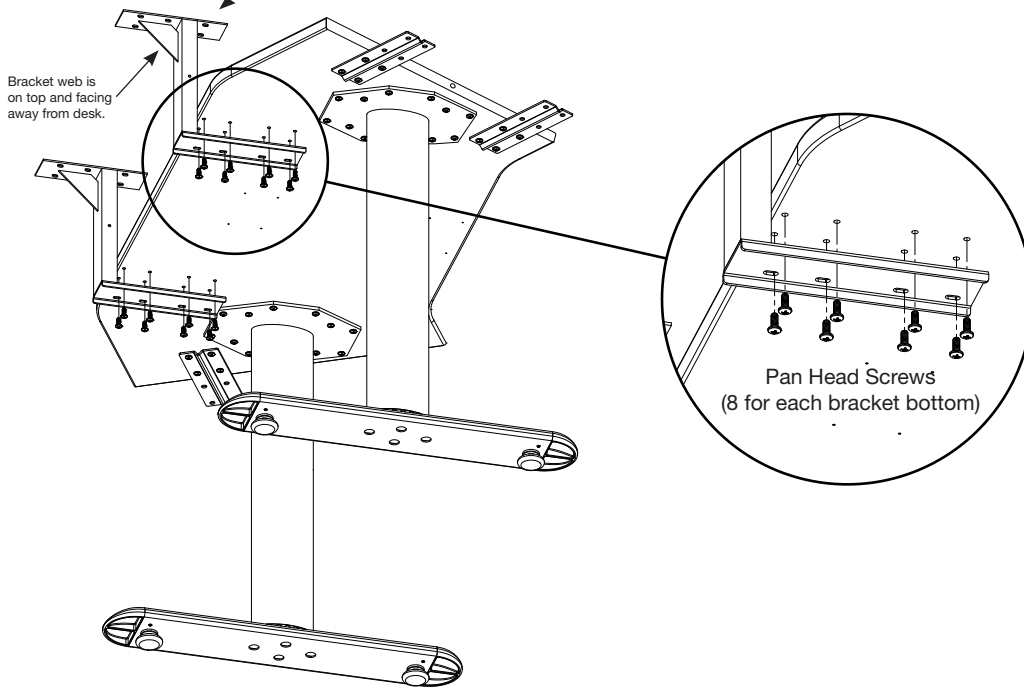

Stand up core desk. Line-up 2nd tier mounting bracket holes with core desk holes. Use eight pan head screws for each bracket bottom.

2nd Tier Platform

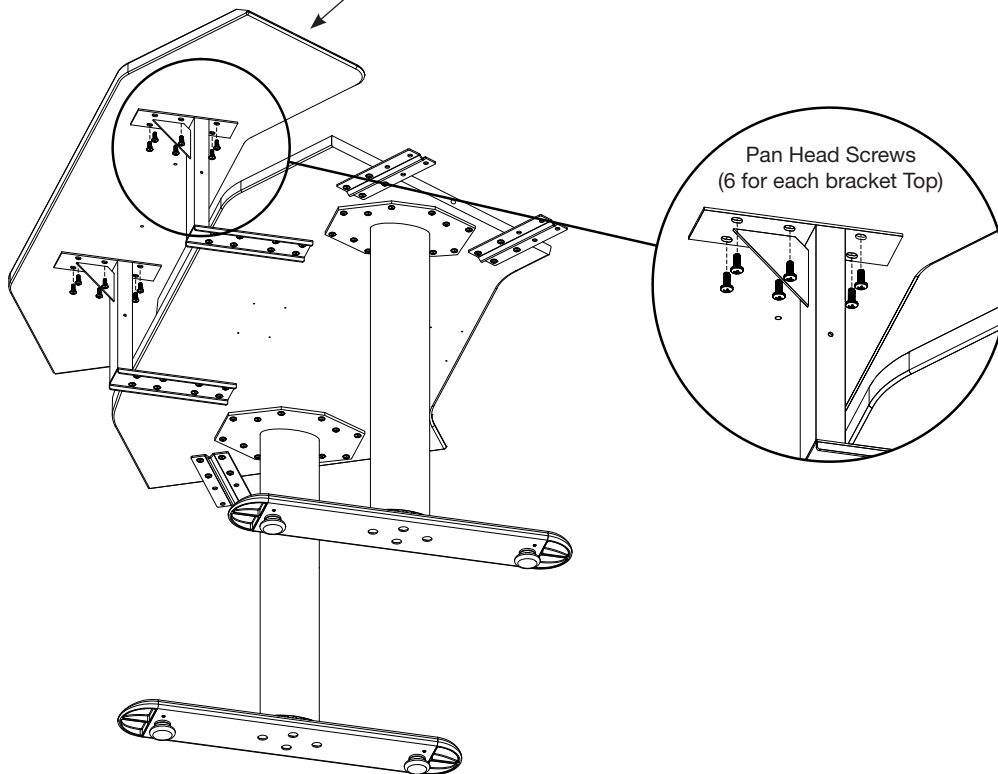

Place 2nd Tier Platform on top of attached 2nd tier bracket and line-up holes. Use six pan head screws for each bracket top.

## NOTE:

If attaching the four space rack, back off all 2nd tier bracket screws a quarter turn from tight. Then slide the assembled four space rack between top tier and main desk surface. See instruction 10 for more details.