

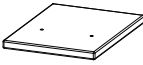

# ULTIMATE SUPPORT®

## Instructions for Assembling 4 Space Rack Cabinet

### Included Parts with the 4 Space Rack Cabinet - BOX 10

	4 Space Rack Rail	x2
	Bottom and Top Board	x2
	Side Board - Left	x1
	Side Board - Right	x1
	1/4 - 20 x 1 3/8" Pan Head Screw	x4
	Flat Washer	x4
	Cam Pin	x8
	Cam Lock	x8
	Dowel Rod	x8
	1/4 - 20 x 5/8" Pan Head Screw	x4

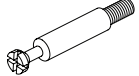
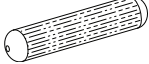
### Included Parts with the 4 Space Rack Cabinet - BOX 1, 2, & 4

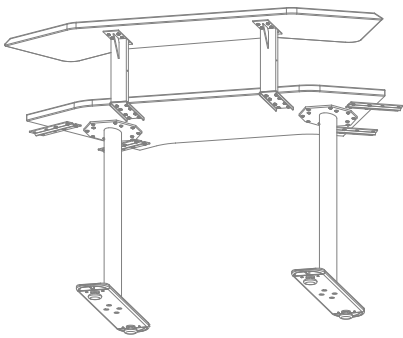
	Assembled core table with legs and second tier (Instructions for assembling core table, legs and second tier are included in box 1, 2, & 4)	x1
--	---	----

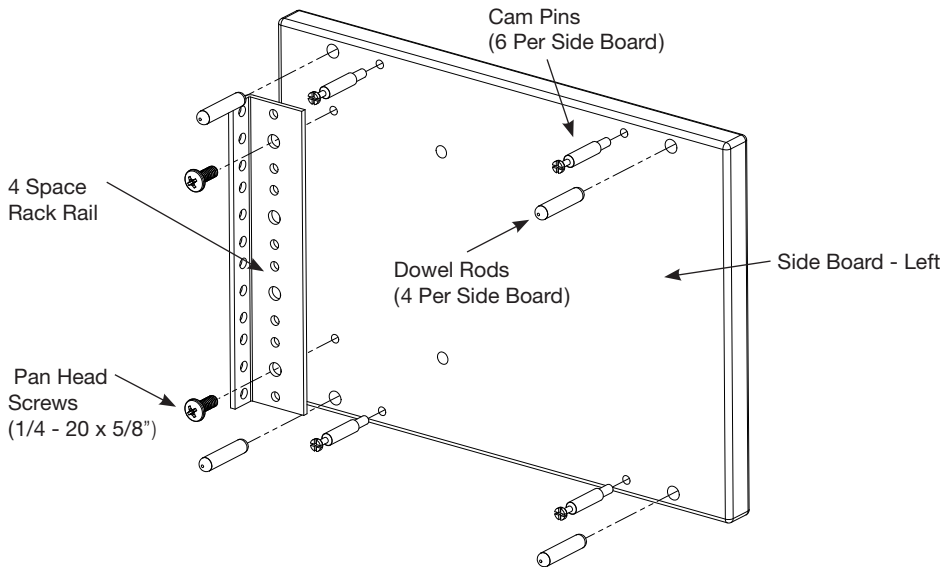

Using the outside four top and bottom holes, push the dowels into left side boards. Using the inside four top and bottom holes, screw cam pins into left side boards. Using two pan head screws (1/4 - 20 x 5/8") attach four space rack rail. Repeat steps for right side board.

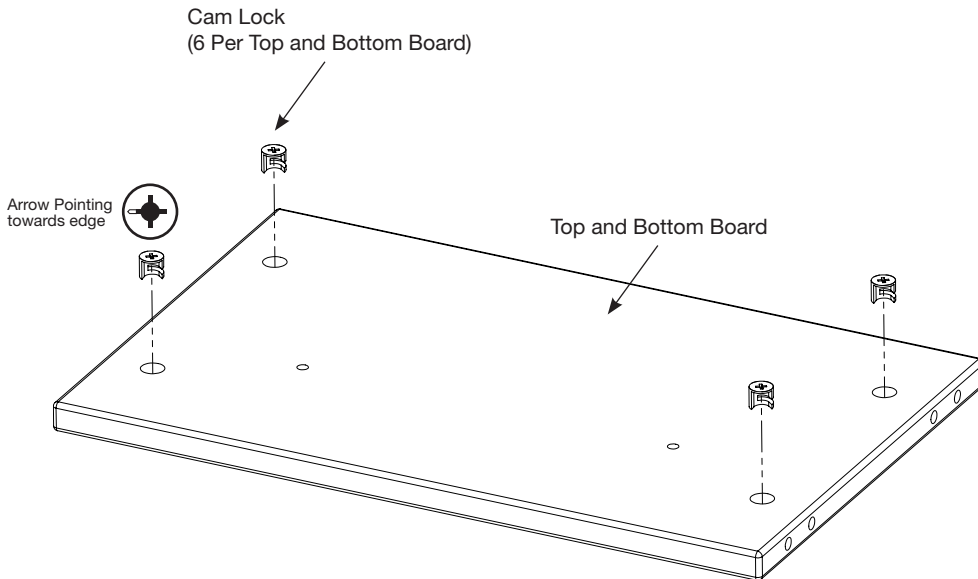

Lay top and bottom board with large holes facing up. Push the four cam locks into large holes on the top and bottom board. The arrow on the cam locks should be pointing towards the edge.

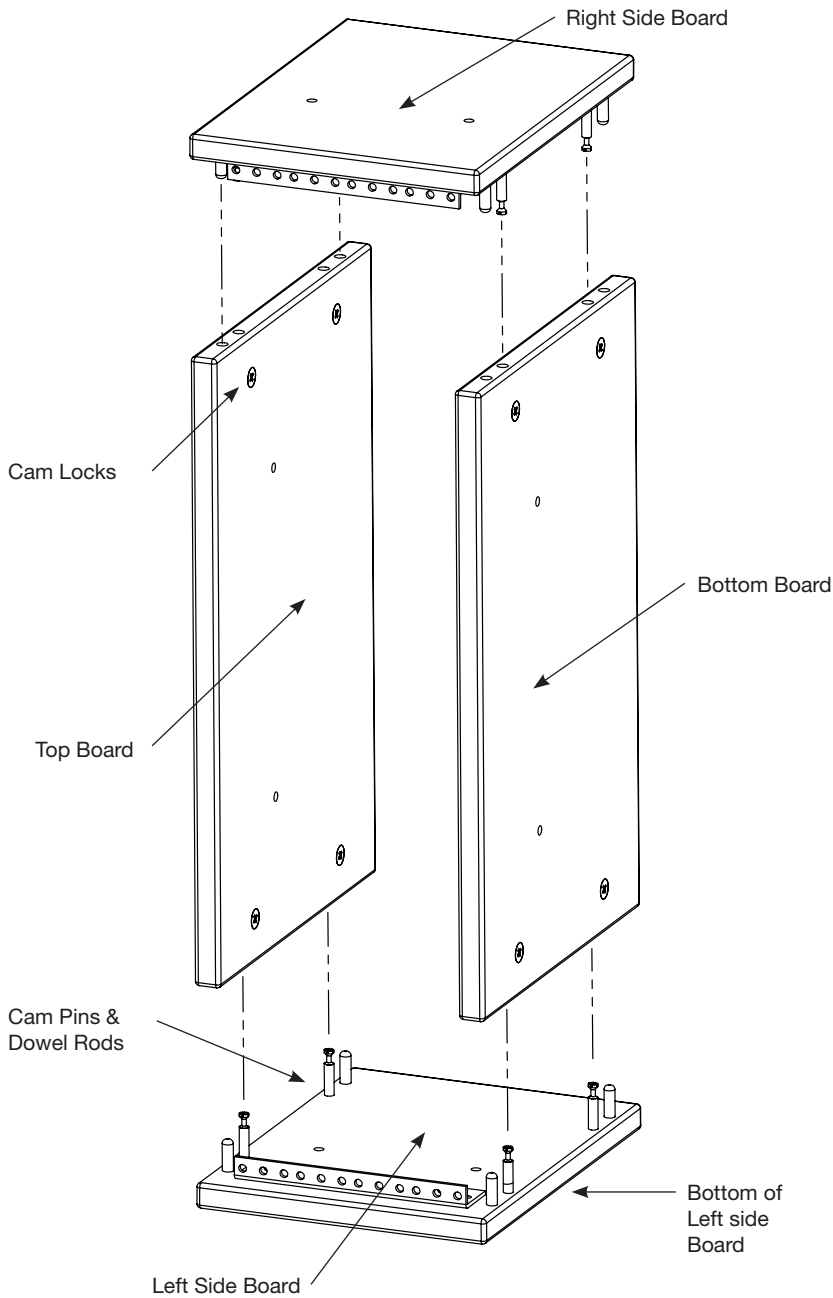

Lay the left side board down with the rack rail facing up. Slide the top and bottom board onto dowel rods and cam pins. On top and Bottom boards make sure the cam locks are facing the bottom of the left side board.

Slide the right side board into the top and bottom boards. Place screw driver into cam lock and turn clock wise to lock cam pins in place (12 Total).

**NOTE:**

If boards are not sliding into place, check cam locks. You may need to turn them counter clock-wise for cam pin to fall into place, then turn clock-wise to lock into place.

While the four space rack rail cabinet is facing front, slide in between both of the 2nd tier mounting brackets. Line-up holes on the 2nd tier platform and mounting brackets with four space rack cabinet. Use the flat washer and pan head screws (1/4 - 20 x 1 3/8") to attach rack cabinet. Screw into sides and top of rack cabinet.

**NOTE:**

If you are adding the four space rack to an existing Nucleus Studio Desk, back off all 2nd tier bracket screws a quarter turn from tight. This will allow you to slide the assembled four space rack between the second tier and desk surface easily. Once the assembled four space rack is in place and attached, re-tighten the pan head screws on the top and bottom second tier brackets.

