

I N S T R U C T I O N M A N U A L

F O R

S I D E - M O U N T E D L E V E L S E N S O R



M O D E L : S H 1 0



Revision 2013-12-06

MUST BE READ BEFORE USING

- This manual is for standard specifications. Read the other manuals for explosion-proof specifications.
- This manual describes the handling, inspection and adjustment of the sensor. Read and understand this manual before installation.
- Any documents and/or directions from Nohken and the agents aside from this manual shall be preceded.
- Save this manual to refer when you need.
- If you have any questions or comments about this manual and/or the sensor, ask Nohken's sales office.

Signal words in this manual means as follows:

 CAUTION	Indicates an potentially hazardous situation which, if not avoided, may result in minor or moderate injury.
 NOTE	Indicates exceptional cases and attention for handling of sensors.

	Indicates prohibition. The explanation with this manual should always be followed.
	Indicates directions. The explanation with this manual should always be followed.

▲ CAUTIONS

• Since this sensor is not an explosion-proof construction, do not use where flammable gas, explosive gas or the vapor exists. Otherwise, explosion the gases and/or the vapor may cause serious disasters. Use explosion-proof sensors at hazard areas.

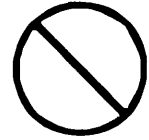

• Do not modify or disassemble the sensor. Otherwise, the sensor may be damaged,

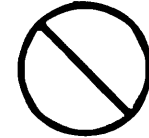

• Operating test shall be conducted before practical use. If malfunction occurs and the accident is predicted, the remedy shall be administrated by using another sensor with different operating principle in parallel.



• To prevent from electric shocks such as lightning and the static electricity, provide conductor or the surge absorber. Otherwise, the sensor may cause malfunction, damage, ignition, electric shock and injury.



▲ NOTES

• Do not give strong shocks to the sensor. Dropping, throwing, striking and dragging the sensor, for example, are to cause strong shocks and damage the sensor.



• The specifications such as ambient temperature, maximum voltage and the power rating shall meet the conditions. Otherwise, the sensor may cause malfunction, damage, ignition, electric shock and injury. Read and check the clause of specification in the manual or specification sheets.



• Operating test shall be conducted before practical use. If malfunction occurs and the accident is predicted, the remedy shall be administrated by using another sensor with different operating principle in parallel.



▲ NOTES

- Check the chemical compatibility with the material you want to use.



- To prevent from electric shocks such as lightning and the static electricity, provide conductor or the surge absorber. Otherwise, the sensor may cause malfunction, damage, ignition, electric shock and injury.



INTRODUCTION

- A. This manual specifies standard specifications of this product. Some specifications may be different from your product if you order the custom-made product.
- B. A variety of specifications are available to meet your process conditions, such as installation conditions, chemical compatibility, and so on. We are glad to offer suggestions to assist your decision.
- C. If you have any questions or comments for the contents of this manual, ask Nohken's sales office written on the front cover.
- D. Nohken Inc. pursues a policy of continuing improvement in design and performance of this product. We will supply the alternative parts or complete new products required to repair or replacement.
- E. Specifications are subject to change without any obligation on the part of the manufacturer.

WARRANTY & DISCLAIMER

- A. Nohken Inc. warrants this product against defects in design, material and workmanship for a period of 1 (one) year from the date of original factory shipment.
- B. If defects occurs during the above-mentioned warranty period, Nohken will, at its option, replace or recondition the product without charge. This shall constitute the exclusive remedy for breach of warranty.
- C. Nohken Inc. makes no warranty with respect to:
 - C-a Failure not to comply with instructions of this manual.
 - C-b Failure or damage due to improper installation, wiring, operation, maintenance, inspection and storing.
 - C-c Product which has been in any way repaired, altered or tampered with by others.
 - C-d Product repaired or modified by using undesignated parts, subassemblies and materials.
 - C-e Direct incidental or consequential damages or losses or expenses resulting from any defective product or the use of any product.
 - C-f Objective of the sensor is clearly specified in chapter 1, PURPOSE OF USE.
 - C-g Inevitable accident such as acts of God, force majeure, radioactive contamination and so on.

THIS WARRANTY IS IN LIEU OF AND EXCLUDES ALL OTHER WARRANTIES OF MERCHANTABILITY OR FITNESS FOR A PARTICULAR PURPOSE.

NOTES TO USERS

It is essential that this manual shall be read and understood before installation and use of the side mounted level switch.

Specifications are subject to change without any obligation on the part of the manufacturer.

TABLE OF CONTENTS

MUST BE READ BEFORE USING
INTRODUCTION
WARRANTY & DISCLAIMER
NOTE TO USERS
TABLE OF CONTENTS

1. PURPOSE OF USE	Page 2
2. PRINCIPLE OF OPERATION	Page 2
3. SPECIFICATIONS	Page 2
3.1 Component name	Page 2
3.2 Standard specifications	Page 3
4. INSTALLATION	Page 4
4.1 Unpacking	Page 4
4.2 Installation site	Page 4
4.3 Installation method	Page 4
5. WIRING	Page 5
5.1 Wiring	Page 5
5.2 Model RE7000 relay unit	Page 5

1. PURPOSE OF USE

The SH10 side mounted level switch is made specifically for liquid level detection. It is designed to install horizontally from outer side of the small tank.

Operation can be reversed to high level or to the low level by revolving the float 180°.

SH10 can be used in a wide range of liquids since it is all made of stainless steel. It's typical usage is vending machine, automatic water supply, small storage tank, and so on.

2. PRINCIPLE OF OPERATION

The SH contain a hermetically-sealed reed switch in the stem and a permanent magnet in the end of the shaft. As the float rises or falls with the level of the liquid, the reed switch is activated by the magnet.

The switch operations, Normally Open or Normally closed, are easily changed by rotating the SH through 180°.

3. SPECIFICATIONS

3. 1 Component name

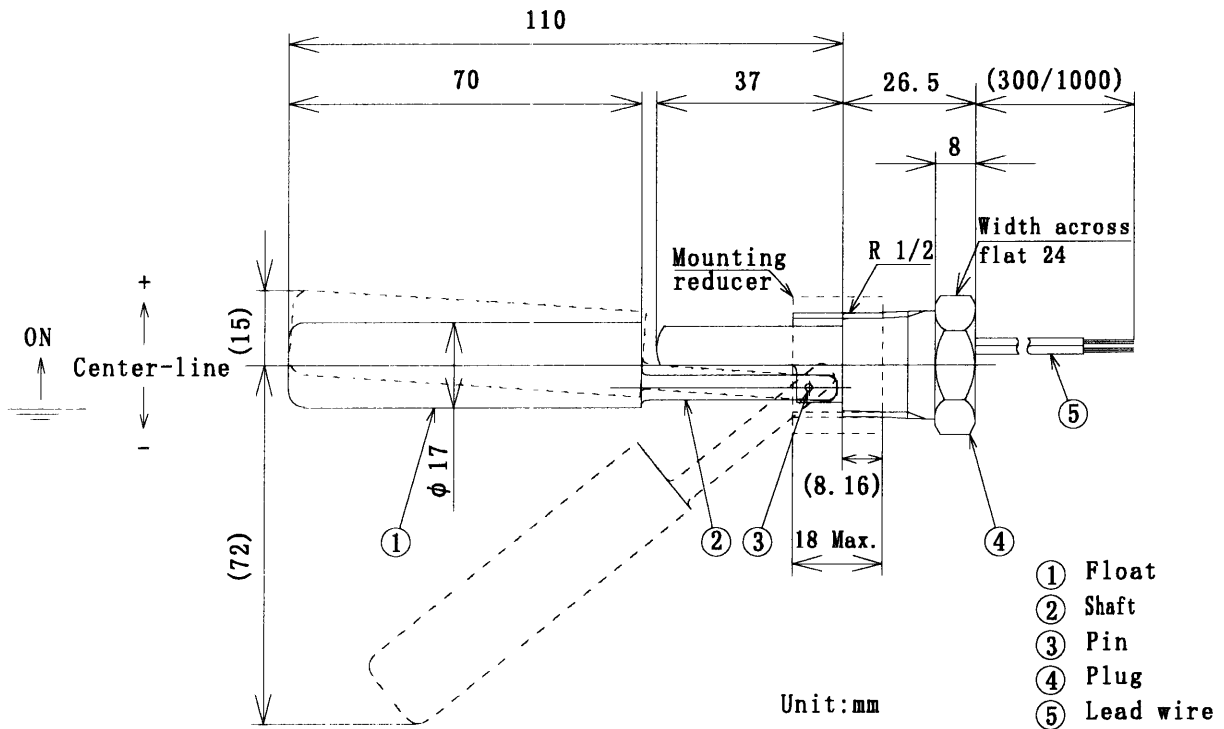

3. 2 Standard specifications

(1) Operation characteristics

- a) Switch actuation level in water (specific gravity = 1.0)
Distance from sensor center-line.

Contact closes : $-5 \begin{smallmatrix} +5 \\ -10 \end{smallmatrix}$ mm ($-2^\circ \sim -10^\circ$ at pin of float)

(In case of rising level)

- b) Specific Gravity: Min. 0.6

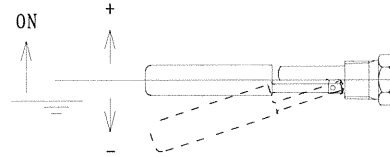

(2) Electrical characteristics

- a) Max. Contact Rating (Resistive Load)

Contact Capacity	50VA AC, 50W DC
Working Current	0.5A AC, 0.5A DC
Working Voltage	300V AC, 300V DC

- b) Life Expectancy : Min. 1×10^7 Operations (12V, 5mA DC)
 c) Withstand Voltage : 1500V AC (1 minute or more.
Between Lead wire and Stem.)
 d) Insulation Resistance: 100M Ω or more (Measured with 500V DC megger.
Between Lead wire and Stem.)

(3) Mechanical characteristics

- a) Withstand pressure : Max. 1 MPa
 b) Tensile strength for Lead wire: Max. 20 N
 c) Allowable impact : 100 m/s²
 d) Working temperature : -10 to +120 $^\circ$ C

(4) Material

- a) Plug : SCS14 (316 stainless steel or equivalent)
 b) Wetted parts: SCS14 (316 stainless steel or equivalent)
316L stainless steel, 316-WPA stainless steel
 c) Lead wire : XLPE (UL3266 AWG22)

(5) Dimensions

- a) Plug : R1/2
 b) Float: $\phi 17 \times H70$

- (6) Mass: Approx. 110g

4. INSTALLATION

4. 1 Unpacking

This switch has been thoroughly inspected and carefully packed at the factory to prevent damage during shipment.

When unpacking, exercise due care not to subject the instrument to mechanical shock.

After unpacking, visually check the instrument exterior for damage.

4. 2 Installation site

- (1) The temperature range is -10 to +120°C.
- (2) Keep away from strong magnetic fields such as those produced by motors, transformers and solenoid valves.
- (3) Install in Non-hazardous area.
- (4) Ample space is provided for maintenance and inspection.



CAUTION

- (1) The float shall be kept free from metallic substances and any other foreign matters in the liquid. Failure to do this may cause malfunction.
- (2) The sealing compound over the lead wire egress will keep moisture, but is insufficient to prevent water penetration. Please install in good location or apply suitable sealant.

4. 3 Installation method

Locate the SH at the position where the liquid level variations will actually make contact with it. Do NOT locate near liquid inlets/outlets. If there is surface wave motion, use a time-delay relay to dampen the switch action.

Thread the female mounting boss. Then screw the SH with a suitable gasket or thread tape.

Max. pull load of lead wire is 20 N. Exceeded pulling during installation may damage the switch.

5. WIRING

5.1 Wiring

All wiring must be done in accordance with all local electrical codes. Lead wire is #22 AWG (Equivalent 0.3mm²). We recommend to use solderless lugs for connection.

⚠ CAUTION

Protection for electrical surges:

1. Overvoltage

Reed switches are not designed for the direct starting of inductive loads such as motors, contactors, solenoid valves, and so on. They are susceptible to damage from overvoltages. **DO NOT EXCEED THE CONTACT RATINGS.** Contact should be wired to miniature relays, suppressors or similar devices. We recommend the use of our relay unit model RE7000.
2. Overcurrent

Momentary surge current may be produced by switching lamps or stray capacity from long cable length. Consequently reed switch is welded. Contact should be wired to our relay unit model RE7000, coils in series or suppressors.

5.2 Model RE7000 Relay unit

We recommend the use of our relay unit model RE7000. It is single level (alarm) and/or dual level (empty/fill control) relay.

The latching (holding relay) feature allows pumps, valves and other devices to be turned on at one level and off at another. It also contribute to safety since it allows lower voltage and smaller currents to be used with SH.

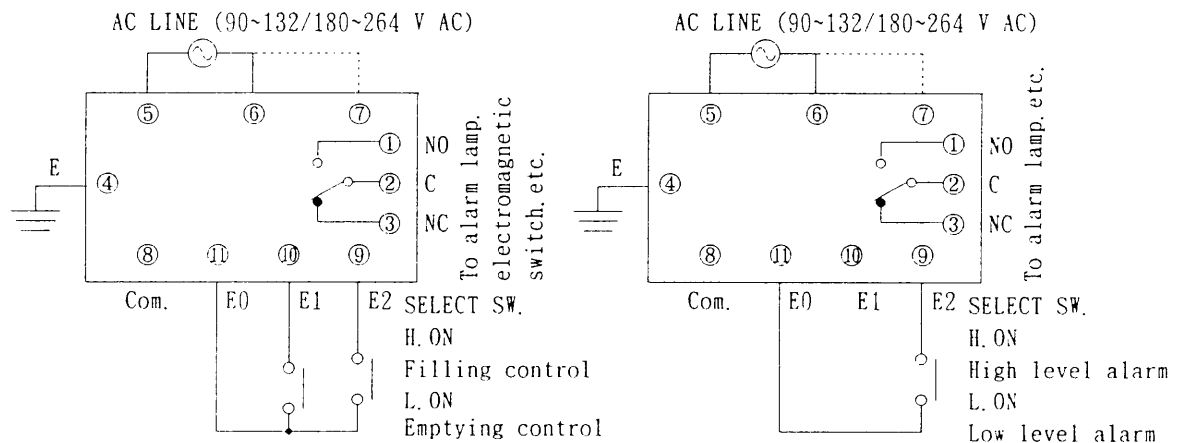

For the relay unit model RE7000, refer to Instruction Manual.

NOHKEN INC.

HEAD OFFICE : 15-29,Hiroshiba-cho,Suita-city,Osaka 564-0052,Japan.

TEL:06-6386-8141 FAX:06-6386-8140

TOKYO BRANCH OFFICE : 67,Kandasakumagashi,Chiyoda-ku,Tokyo 101-0026,Japan.

TEL:03-5835-3311 FAX:03-5835-3316

NAGOYA OFFICE : 3-10-17,Uchiyama,Chikusa-ku,Nagoya-city,Aichi 464-0075,Japan.

TEL:052-731-5751 FAX:052-731-5780

KYUSHU OFFICE : 14-1,2-chome,Asano,Kokurakita-ku,Kitakyushu-city,Fukuoka 802-0001,Japan.

TEL:093-521-9830 FAX:093-521-9834