

I N S T R U C T I O N   M A N U A L  
F O R

M I N I A T U R E   F L O A T   S E N S O R

M O D E L :   L   S

Issued      Aug. 25, 1999



**NOHKEN INC.**



---

# MUST BE READ BEFORE USING

- This manual is for standard specifications. Read the other manuals for explosion-proof specifications.
- This manual describes the handling, inspection and adjustment of the sensor. Read and understand this manual before installation.
- Any documents and/or directions from Nohken and the agents aside from this manual shall be preceded.
- Save this manual to refer when you need.
- If you have any questions or comments about this manual and/or the sensor, ask Nohken's sales office.

Signal words in this manual means as follows:

 <b>CAUTION</b>	Indicates an potentially hazardous situation which, if not avoided, may result in minor or moderate injury.
 <b>NOTE</b>	Indicates exceptional cases and attention for handling of sensors.

	Indicates prohibition. The explanation with this manual should always be followed.
	Indicates directions. The explanation with this manual should always be followed.



## CAUTIONS

• Since this sensor is not an explosion-proof construction, do not use where flammable gas, explosive gas or the vapor exists. Otherwise, explosion the gases and/or the vapor may cause serious disasters. Use explosion-proof sensors at hazard areas.



• Do not modify or disassemble the sensor. Otherwise, the sensor may be damaged,

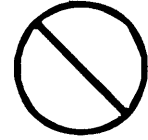

• Operating test shall be conducted before practical use. If malfunction occurs and the accident is predicted, the remedy shall be administrated by using another sensor with different operating principle in parallel.



• To prevent from electric shocks such as lightning and the static electricity, provide conductor or the surge absorber. Otherwise, the sensor may cause malfunction, damage, ignition, electric shock and injury.



• When connecting inductive load or the lamp load to the relay output contact.



To prevent over voltage and over current, provide a protective circuit to the load. Otherwise, the contact may be damaged.



## NOTES

• Do not give strong shocks to the sensor. Dropping, throwing, striking and dragging the sensor, for example, are to cause strong shocks and damage the sensor.

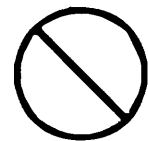

• The specifications such as ambient temperature, maximum voltage and the power rating shall meet the conditions. Otherwise, the sensor may cause malfunction, damage, ignition, electric shock and injury. Read and check the clause of specification in the manual or specification sheets.



• Operating test shall be conducted before practical use. If malfunction occurs and the accident is predicted, the remedy shall be administrated by using another sensor with different operating principle in parallel.



▲ NOTES

- Check the chemical compatibility with the material you want to use.

A minor corrosion to the float and the thin thickness part may be chemically effected.



- To prevent from electric shocks such as lightning and the static electricity, provide conductor or the surge absorber. Otherwise, the sensor may cause malfunction, damage, ignition, electric shock and injury.



## INTRODUCTION

- A. This manual specifies standard specifications of this product. Some specifications may be different from your product if you order the custom-made product.
- B. A variety of specifications are available to meet your process conditions, such as installation conditions, chemical compatibility, and so on. We are glad to offer suggestions to assist your decision.
- C. If you have any questions or comments for the contents of this manual, ask Nohken's sales office written on the front cover.
- D. Nohken Inc. pursues a policy of continuing improvement in design and performance of this product. We will supply the alternative parts or complete new products required to repair or replacement.
- E. Specifications are subject to change without any obligation on the part of the manufacturer.

# WARRANTY & DISCLAIMER

- A. Nohken Inc. warrants this product against defects in design, material and workmanship for a period of 1 (one) year from the date of original factory shipment.
- B. If defects occurs during the above-mentioned warranty period, Nohken will, at its option, replace or recondition the product without charge. This shall constitute the exclusive remedy for breach of warranty.
- C. Nohken Inc. makes no warranty with respect to:
  - C-a Failure not to comply with instructions of this manual.
  - C-b Failure or damage due to improper installation, wiring, operation, maintenance, inspection and storing.
  - C-c Product which has been in any way repaired, altered or tampered with by others.
  - C-d Product repaired or modified by using undesignated parts, subassemblies and materials.
  - C-e Direct incidental or consequential damages or losses or expenses resulting from any defective product or the use of any product.
  - C-f Objective of the sensor is clearly specified in chapter 1, PURPOSE OF USE.
  - C-g Inevitable accident such as acts of God, force majeure, radioactive contamination and so on.

THIS WARRANTY IS IN LIEU OF AND EXCLUDES ALL OTHER WARRANTIES OF MERCHANTABILITY OR FITNESS FOR A PARTICULAR PURPOSE.

---

MUST BE READ BEFORE USING

WARRANTY & DISCLAIMER

TABLE CONTENTS

1. GENERAL DESCRIPTION . . . . .	1
2. OPERATING PRINCIPLE . . . . .	1
3. INSTALLATIONS FOR HANDLING . .	1
3-1 Wiring Method . . . . .	1
3-2 Installation Methods . . . . .	4
3-3 Cares for handling . . . . .	5



## 1. GENERAL DESCRIPTION

The LS Switch, which has been developed for use in apparatus such as water heaters, automatic vending machines, etc., is used to detect liquid level in tank at a fixed level to give an alarm or control solenoid valve, pump, etc.

## 2. OPERATING PRINCIPLE

In the construction of the LS Switch, a column-shaped stem is protruded from the switch and a lead switch is fixed and sealed in the stem. A float which vertically moves along the stem is provided and a magnet is installed inside the float.

This means that the magnet moves vertically as the float moves vertically. This causes relative change in the distance of the lead switch fixed to the magnet by which the lead switch is turned ON and OFF.

## 3. INSTRUCTIONS FOR HANDLING

### 3-1 Wiring Method

#### a. Alarm Circuits

- o Typical wiring examples are illustrated in Figs. 1 to 2.

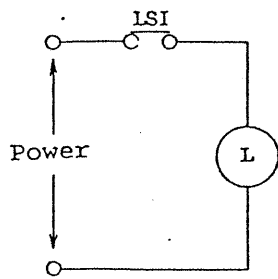

Fig. 1

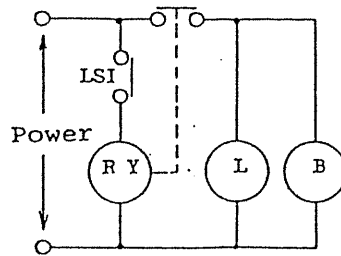

Fig. 2

LS<sub>1</sub> : Contacts of level switch

L : Alarm lamp

B : Alarm buzzer

RY : Relay coil

- o If the maximum load current exceeds the maximum breaking current, or exceeds the maximum breaking capacity, an auxiliary relay must be used as shown in Fig. 2.

- o The use of a hinge-type small relay or our Type RU-100 Relay Unit is recommended as the auxiliary relay.

b. Control Circuits

- o An example of circuits when supply control is performed between the two contacts of upper and lower limit is shown in Fig. 3.

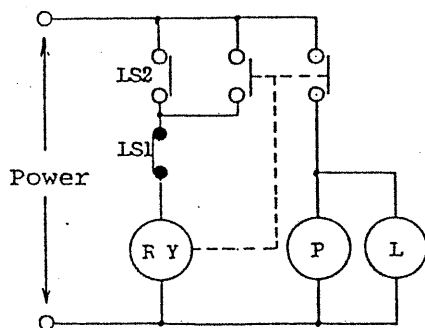

Fig. 3

LS<sub>1</sub> : Contacts of level switch for upper limit (upper limit: OFF)

LS<sub>2</sub> : Contacts of level switch for lower limit (lower limit: ON)

RY : Relay coil

P : Supply pump (magnet switch) solenoid valve

L : Operation indicating lamp



- o An example of circuits where discharge control is performed between the two contacts of upper and lower limits is shown in Fig. 4.

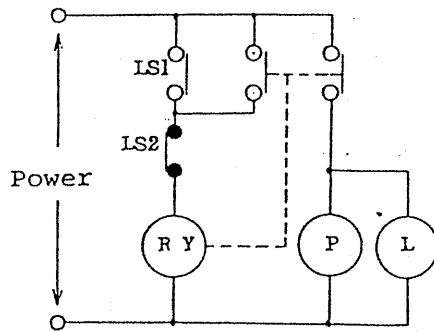

Fig. 4

- LS<sub>1</sub> : Contacts of level switch for upper limit (upper limit: ON)
- LS<sub>2</sub> : Contacts of level switch for lower limit (lower limit: OFF)
- RY : Relay coil
- P : Discharge pump (magnet switch) solenoid valve
- L : Operation indicating lamp

- o An example of circuits where liquid supply is stopped by closing supply valve when the level reaches the upper limit is shown in Fig. 5.

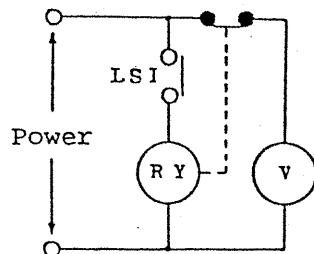

Fig. 5

- LS<sub>1</sub> : Contacts of level switch for upper limit (upper limit: ON)
- V : Magnet valve (normally closed)
- RY : Relay coil

3-2 Installation Methods

- o Typical installation examples are shown in Fig. 6.

INSTALLATION EXAMPLE

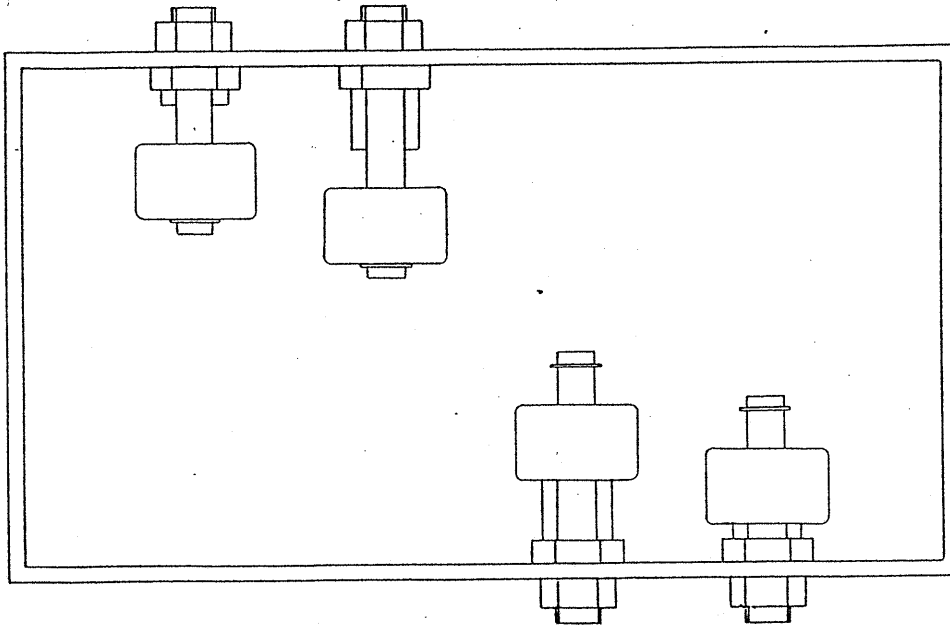

Fig. 6

### 3-3 CARES FOR HANDLING

- a. Since a magnet is set in the lead switch in this level switch and in its float, care must be taken not to place such an object which may disturb the magnetic field, near the level switch (float).
- b. Take care not to give heavy impact to the level switch and the float.
- c. Take care not to allow the maximum load current exceeds the maximum breaking current or maximum breaking capacity.
- d. If the switch capacity is not enough, use a hinge-type small relay or our Type RU-100 Relay Unit.
- e. Do not pull lead wires with a strong force.

# NOHKEN INC.

HEAD OFFICE : 15-29,Hiroshiba-cho,Suita-city,Osaka 564-0052,Japan.

TEL:06-6386-8141 FAX:06-6386-8140

TOKYO BRANCH OFFICE : 67,Kandasakumagashi,Chiyoda-ku,Tokyo 101-0026,Japan.

TEL:03-5835-3311 FAX:03-5835-3316

NAGOYA OFFICE : 3-10-17,Uchiyama,Chikusa-ku,Nagoya-city,Aichi 464-0075,Japan.

TEL:052-731-5751 FAX:052-731-5780

KYUSHU OFFICE : 14-1,2-chome,Asano,Kokurakita-ku,Kitakyushu-city,Fukuoka 802-0001,Japan.

TEL:093-521-9830 FAX:093-521-9834