

Flumsys 10TC-SP Streaming Current

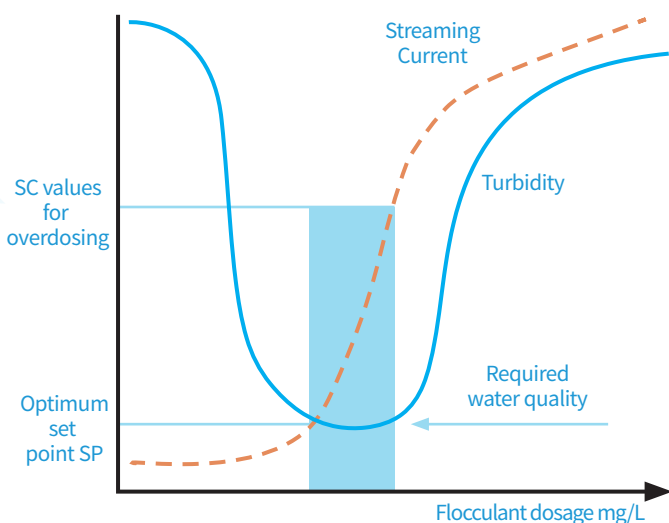

Advantage

- Automatic control of the dosing of flocculant
- cut costs
- Maintain Water Quality
- Low operating and maintenance costs
- Real-time pH monitoring
- Durable, reliable and easy to control dosing system



The streaming current is used to continuously measure the electric charge on the tiny suspended particles and colloids in the liquid. The electric charge is measured by electronic signal processing.

The measurement result is converted into A.C signal or flowing current (SC). The value of flowing current (SC) is proportional to the charge density. The charged state depends on the water after flocculation.

The excess positive and negative charges can quickly react to changes in water characteristics (such as chromaticity and turbidity) by detecting the changes in the flowing current (SC) value, thereby making the operation. The personnel can adjust the metering of the flocculant accordingly.

The Flumsys 10SC streaming current can be equipped with a pretreatment system to ensure the long-term trouble-free operation of the instrument, with continuous measurement, automatic cleaning, PH measurement and PID control function can be connected to the existing dosing system and start automatic dosing control. The amount of flocculant will be automatically adjusted according to the characteristics of the water.

Applications:

Waterworks, Sewage treatment plant, Sludge dewatering, Need to add flocculant process

Measured parameters:

Streaming Current/SCD, pH

Features

- Simultaneous display of actual SC value and relative SC value
- Simultaneous pH monitoring (optional) for real-time knowledge of flocculation effects
- Automatic cleaning function
- PID control function
- SC 4-20mA and PID 4-20mA output
- 2 high/low alarm output
- RS485 Modbus RTU communication
- 4.3" colour touch screen, easy to operate
- Password protection to prevent unauthorized operation
- Data recording function, support U disk to export (Excel)
- Automatic control / manual control two modes
- Split sensor design for easy installation on site
- Optional pretreatment system, greatly reducing maintenance

Water Quality Requirements

- Conductivity: < 3000µS/cm
- pH: 4~11pH (pH < 7 after controlled flocculant application, SCD measurement is best)
- Optional pre-treatment system for extended maintenance intervals

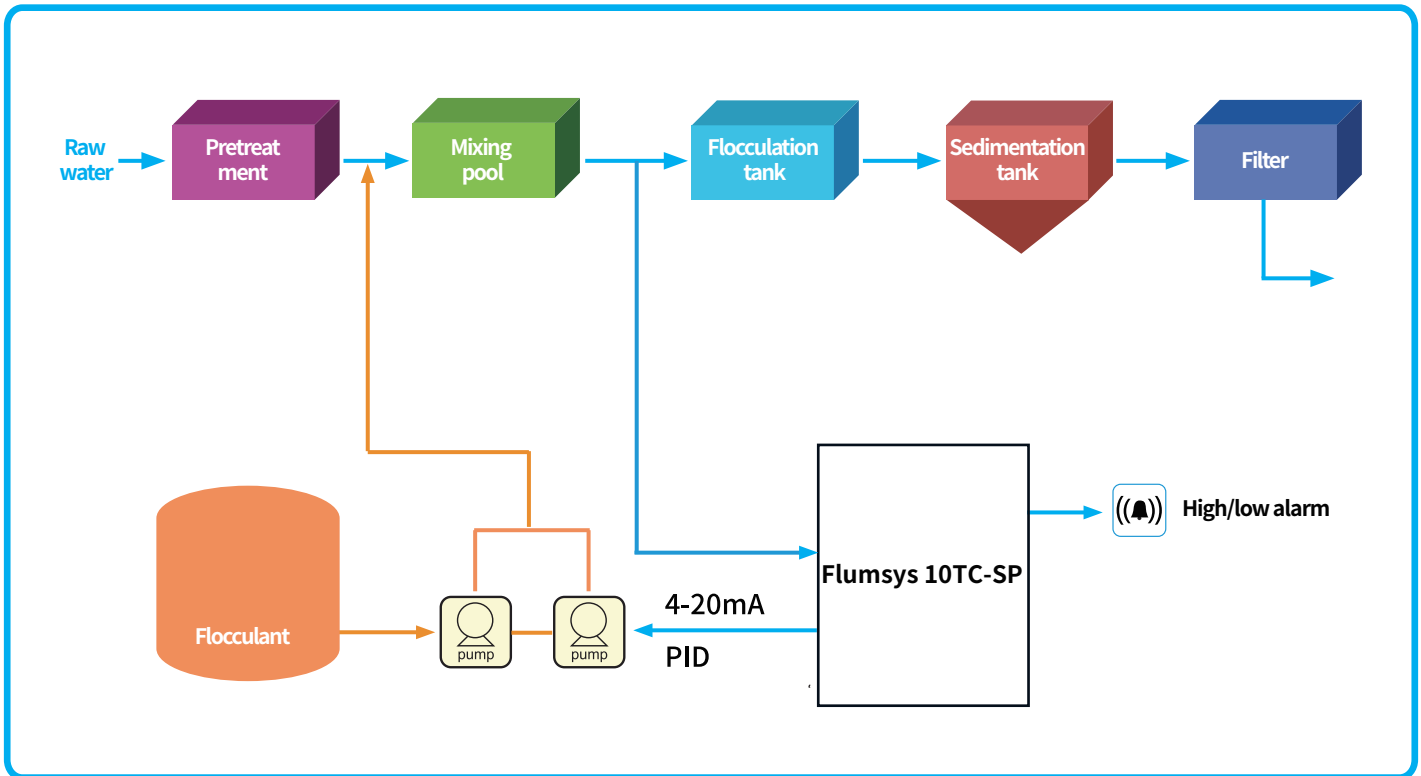

Technical parameters

Measuring parameter:	Streaming Current/SCD, pH
Measurement range:	-1000~1000SC 0-14pH
Accuracy:	±0.1% ±0.01pH
Repeatability:	±0.1%
Response time:	1s
Operating temperature:	0-50°C
Liquid connection material:	PTFE、POM、SS316
Housing:	ABS/PC
Power supply:	220VAC, 50/60Hz
Analogue output:	2 x 4-20mA (measured value and PID), max. load 500Ω
Relay output:	2 high/low relays, alarm value and hysteresis can be set
Automatic cleaning:	cleaning interval: 0-9999min, cleaning time: 0-999s
Digital communication:	RS485 Modbus RTU
Data storage:	Real time data recording, U disk export support (Excel format)
Sampling requirements:	flocculant dosing point to sensor time about 3-5min
Flow rate requirement:	1~4L/min
Protection class:	IP65
Dimensions: Controller:	Controller: 200x190x90mm, Sensor: 250x350x150mm
Weight:	Controller: 1Kg, Sensor: 5Kg

Order Guide

Item no.	Description
32-5510-20	Flumsys 10TC-SP-0 Streaming Current Detector/ pH Analyzers, 220VAC
33-5510-11	Cleaning solenoid valves
33-5510-12	Filters
33-5510-10	PTFE kit
35-0125-10	innoSens 125T pH/TSensor