

15J/30J – P1

GAS SENSOR TRANSMITTER

Safe Area Detector Head / Junction Box Assembly

Specification Sheet
ref C.1274Av.7

- Flexible output options
- CANbus, 4~20mA output
- Addressable or stand alone
- Hyperterminal communications RS232 line data and set up with 232 adapter
- Data logging
- Optional alarm relays
- Backlit alpha numeric full status display (*optional*)
- Robust and weatherproof



15J-P1

The 15/30J enclosure has been designed to allow quick and easy access to its interior by adjustment of two allen screws, this factor is a major consideration when large system service and calibrations are being carried out.

The detector is robust and weather-proof with improved response times due to the four mounting spacers allowing increased air movement around the detector these spacers also improve the mounting of the unit particularly on circular pillars typically found in car parks. Standard 4~20mA signalling with CANbus address enables the sensors to be networked via the GDS Combi control system or customer preferred monitoring system.

Power Supply

15 to 30vDC 24v nominal

Outputs

3 wire – 4~20mA

4 wire – CANbus

Relays (optional)

Low alarm S.P.C.O

High alarm S.P.C.O

Fault alarm S.P.C.O / overrange

Rating 0.5A @30vDC

Display (optional)

2 line alpha numeric backlit status display – gas type, concentration units, alarm levels, alarm status – low/high/overrange/sensor ID

Sounder/Relay (optional)

Single relay – low/high alarm selectable

S.P.C.O 0.5A @30vDC

Sounder – not less than 85dB @ 30 cm

Logging

Addressable sensors only

Intervals – variable time

Roll over/stop

Storage – 2,880 readings

Temperature

–15 °C to 55 °C

Humidity

Pellistor-catalytic

0 – 99% RH non condensing

Electrochemical

5 – 95% RH non condensing

Infrared

0 – 95% RH non condensing

DETECTOR HEAD

Type – P1 Safe area use

Ingress Protection

IP63 + Universal fitting IP65

Material

ABS – black

Sensor Inserts – 4 series

Electrochemical

Infra Red

Semiconductor

Pellistor – Catalytic

PID

Accessories – Optional

Collector Cone + Universal Fitting

Universal Fitting (test gas applicator/spray deflector)

Flow Block

Duct Mount Kit

Detector Head Weather Shield

JUNCTION BOX

Type – 15/30J safe area use only

15J – shallow box (S)

30J – deep box (D)

Ingress Protection

IP64

Material

ABS Flame retardent FR40

Lid Screws M4SS

Finish

Signal White RAL 9003

Weight

380gms

Entries

Rear 5–20mm knock outs

Sides, Top, Bottom – not specified

Mounting

Standoffs – M4 or No 8 screws

Drill at (C) when standoffs removed

Conduit box – drill at (A) 4.5mm

Surface mount box – drill at (B) 4.5mm

EU Design No.

01359723–0001

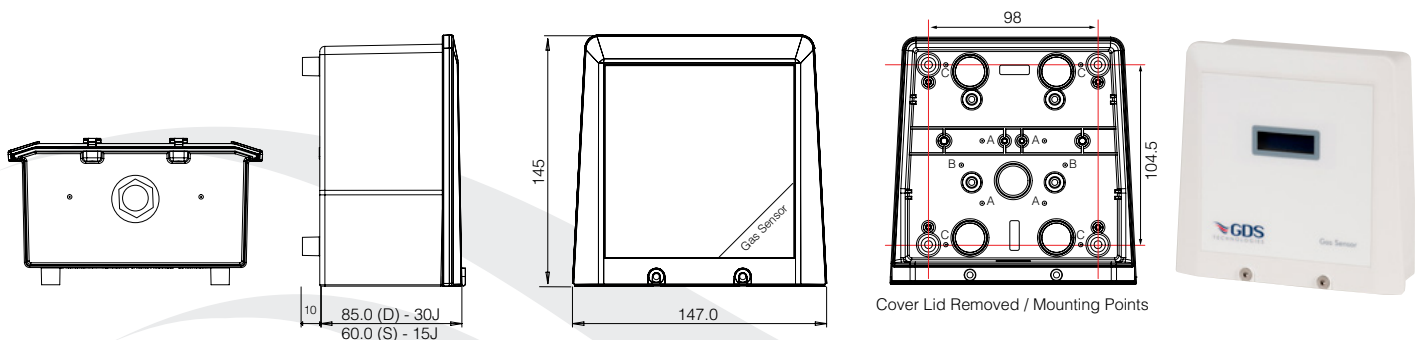

This document is not contractual and the equipment specification may be modified at any time without prior notice.

